

Timing & Time Code Reference



REFERENCE GUIDE

TABLE OF CONTENTS

Time Scales of Measurement

Introduction.....	1
Definition of Time	1
Universal Time (UT0).....	1
Time and Navigation.....	1
UT1	2
UT2	2
Ephemeris Time	2
Atomic Time	2
Coordinated Universal Time.....	2
Local Time	3
Formal Definitions of Time Interval.....	3
Accurate Time: A Summary	3

Digital Clock Accuracy and Synchronization

Introduction.....	4
Time Base Standards in Clocks.....	4
Cesium Beam Standards (Cs).....	4
Hydrogen Maser	4
Rubidium Standard (Rb)	4
Quartz Oscillators.....	5
Sources of Oscillator Error	5
Accumulated Time Error versus Elapsed Time	6
Setting the Clock	7
WWV, WWVH, WWVB Time Synchronization.....	7
Loran	7
Geostationary Operational Environmental Satellite (GOES)	7
Transit (Navy Navigation Satellite System, NNSS)	7
Global Positioning System (GPS)	7
Selection and Use of Time Code Formats.....	8
Inter Range Instrumentation Group (IRIG) Time Code Formats	8
Description of IRIG Time Code Formats.....	9

IRIG Time Code Formats

IRIG Standard Format A 1000 PPS Code.....	10
IRIG Standard Format B 100 PPS Code	11
IRIG Standard Format D 1 PPM Code	12
IRIG Standard Format E 10 PPS Code.....	13
IRIG Standard Format G 10 KPPS Code	14
IRIG Standard Format H 1 PPS Code	15

Other Time Code Formats

NASA 36-Bit One-Second Time Code.....	16
NASA 28-Bit One-Minute Time Code	17
NASA 20-Bit One-Hour Time Code.....	18
XR3/2137 25 PPS One Second Time Code.....	19
Symmetricom Bi-Level 5-Rate Slow Code	20
WWV/WWVH Time Code	21
WWVB Time Code	22

IEEE 1344 Compliance	23
----------------------------	----

TIME SCALES OF MEASUREMENT

Introduction

Many centuries have been spent devising methods for the determination and measurement of time. In the beginning, time requirements were quite crude, mostly limited to the prediction of such phenomena as seasonal changes and, the ability to divide a day into smaller, more understandable and predictable segments.

Ultimately, the determination of time was reduced to scales of measurement. The earliest references for use in the calculation of time scales were the sun and moon. By observation of the moon's various stages, a reliable and repeatable scale could be devised for dividing a seasonal year into a number of fairly equal segments.

As the ability to make astronomical measurements was further refined, our ancestors turned to the sun for a more precise reference. Like the moon, the sun provided a constant and repeatable reference from which to devise more precise scales of time measurement. The sundial is the most familiar of these early attempts.

Until fairly recently, the sun's position defined the time of day. When the sun was not visible it was impossible to know the exact time, so clocks were developed to measure out the hours between checks with the sun. The study of different clocks is an interesting branch of history, but this history will be reviewed only to the extent needed to understand the meaning of "accurate time."

All clocks measure time, but different clocks can have different status or importance. For example, a clock can be a primary reference, like the sun's position, or a secondary reference, which only interpolates between checks with the primary clock or time standard, thus providing an approximation of time.

Definition of Time

In order to understand time, the concepts

of date, interval and synchronization must be first understood. "Time" can mean either date or time interval (i.e., duration). An example of date is November 15, 1996, 15:35:14 PST (Pacific Standard Time), where 15:35:14 indicates time of day in hours, minutes and seconds. An example of time interval is the amount of time required to fly between two cities, say 3h:51m:12s. This latter example gives no indication of when (i.e., the date) the flight occurred, only that it lasted 3 hours, 51 minutes, 12 seconds. Note that a notation of hours, minutes and seconds can indicate either time of day or duration.

Synchronization is the third important time concept. For example, it is not normally crucial for an orchestra to begin its concert at a precise hour, minute or second of the day, but it is essential that all members of the orchestra begin at the same instant and that they stay at the same tempo. A gasoline engine's timing must be correct within a thousandth of a second or so, otherwise the sparks will not fire the fuel at just the right time to provide power to the pistons. Beyond the casual user, many electronic navigation systems, computer networks and even television receivers require synchronization to transmitted signals with an accuracy of a millionth of a second or better.

A time scale is a system of assigning dates to events. The sun's apparent motion in the sky provides one of the most familiar time scales, but it is certainly not the only one. In order to completely specify a solar date, you must count days (i.e., make a calendar) from some beginning date to which all parties have agreed. In addition (depending on accuracy needs), you must measure the fractions of days (commonly, hours, minutes and seconds). That is, you must count cycles (and fractions of cycles) of the sun's daily apparent motion around the earth. Time derived from the sun's apparent position is called apparent solar time. A sundial indicates the fractions of cycles (i.e., time of day) directly. Calendars, like the

Gregorian Calendar which we commonly use, aid in counting the days and naming them. Another system, used by astronomers, is called Julian Day. It numbers the days that have occurred since noon January 1, 4713 B.C. In this system (which is not related to the Julian Calendar) noon January 1, 2000 began day 2,451,910. This time scale is useful for calculating the number of days between two events.

Universal Time (UT0)

Since the earth's orbit around the sun is not a perfect circle, apparent solar time cannot be a uniform time scale. That is, the time interval between successive (apparent) noons changes throughout the year. The length of this solar day is also affected by the inclination of the earth's spin axis to the plane of the earth's orbit.

To correct for these non-uniformities, astronomers calculated the effects of the earth's noncircular orbit and the polar inclination on apparent solar time. Universal Time (UT0) is apparent solar time corrected for these two effects. The correction used to obtain UT0 is called the Equation of Time. It is often engraved on sundials, a correction which adds or subtracts up to 15 minutes to or from apparent solar time, depending on the season.

Astronomers actually measure Universal Time using the stars rather than the sun. If you count cycles (and fractions) of a distant star's apparent position, you get a different time scale, called sidereal (pronounced "sy-deer-e-al") time. Since the earth circles the sun once each year but does not circle the distant star, sidereal time accumulates one more "day" each year than Universal Time (and our calendar). The "clock" for both Universal Time and sidereal time is the spinning earth; only the counting methods differ. In actual practice, astronomers observe sidereal time and correct it to get Universal Time.

Time and Navigation

Time is essential to navigation. In effect, a navigator, using a sextant, determines the local time based on the sun's apparent position. The difference between his local time and Universal Time (or Greenwich time) is equivalent to the local longitude, since zero longitude passes through Greenwich, England.

Even though we express longitude in degrees, not hours, minutes and seconds, the difference in time is proportional to the difference in longitude. Since the earth makes about one revolution (360°) relative to the sun in 24 hours, the translation to degrees is simple: $360^\circ/24\text{h} = 15^\circ$ per hour. The navigator's sextant is the means of determining local apparent solar time and the navigator's clock (chronometer) and the means of determining Universal Time. As a result of using Universal Time for navigation, scientists developed two refinements of UT0: UT1 and UT2.

UT1

Scientists discovered many years ago that the earth is not fixed on its axis. In effect, what one sees is a wandering of the poles relative to the fixed astronomical observatories, which causes UT0 to vary. The logical response to such a situation is to calculate a correction for polar motion and apply it to UT0. UT1 is the result of this correction. The difference between UT0 and UT1 is quite small; only about ± 0.3 second (± 300 milliseconds).

UT2

As the accuracy and consistency of pendulum and quartz crystal clocks improved, scientists discovered many years ago that UT1 had periodic fluctuations of unknown origin of periods of one year and one-half year. Since these periodic variations are predictable, astronomers are able to correct UT1 to get a still more uniform time scale, UT2. Again, the corrections are small, about ± 0.3 second. Thus, there exists a family of Universal Times based on the earth's spin and other refinements:

- UT0 is apparent solar time corrected for the earth's noncircular orbit and inclined axis.
- UT1 is the true navigator's time scale related to the earth's actual angular position relative to the sun.
- UT2 is a smoothed time scale and does not affect the real periodic variations in the

earth's angular position. At least in principle, if not in practice, UT2 passed by the navigator's needs. UT2 is not much used any more.

Ephemeris Time

Near the end of the 19th century, Simon Newcombe at the U.S. Naval Observatory compiled a set of tables which predicted the future positions of the sun, moon, and some planets. He based these predictions on the best data and physical principals available at that time. A table of this sort is called an ephemeris.

Newcombe discovered that the actual positions gradually departed from the predicted positions in a fashion too significant to be explained either by observational errors or approximations in the theory. He noted that if the time were somehow in error, all the tables agreed well with the observations. At this point he correctly determined that in addition to all the variations noted above, there are random fluctuations in the earth's rotational rate. Later, quartz and atomic clocks confirmed that the variations exist.

The astronomer's natural response to this was, in effect, to use Newcombe's tables for the sun in reverse to determine time, a time scale called Ephemeris Time (ET). The earth's orbital (not rotational) position determines Ephemeris Time, and ET should be more uniform than Universal Time because geometrical changes in the earth's shape do not affect the orbital motion. ET is not very convenient to use because an accurate determination of ET requires literally years of astronomical observations. In the early 1950's, more convenient and precise clocks were developed: atomic clocks. The atomic clocks provide the uniformity of ET, but are far more convenient to use.

Atomic Time

It was mentioned earlier that counting the number (and fractions) of cycles of the apparent sun determines a date on the Universal Time scale. Similarly, counting the number of cycles of an electronic signal whose frequency is controlled by an atomic or molecular resonance determines date on an atomic time scale. In most atomic clocks, electronic circuits steer a radio frequency into resonance with a specific atomic or molecular transition (vibration). The resonance is an atomic or molecular property, and its frequency

can be relatively insensitive to temperature, magnetic fields, and other environmental conditions. Thus, these resonances form natural standards of frequency. Atomic clocks are formed by counting the cycles of these atomically or molecularly controlled radio signals.

Today scientists and engineers have perfected clocks based on a resonance in cesium atoms to an accuracy of better than one part in 10⁻¹³ (one part in 10 trillion). Expressed another way, these clocks keep pace with each other to within two or three millionths of a second over a year's time. The earth, on the other hand, might randomly accumulate nearly a full second's error during a year. Since there are now literally thousands of atomic clocks in use, and since they agree well with each other, the variations in the earth's rotation rate are easily measured.

International Atomic Time (TAI) is an atomic time scale maintained by the Bureau International de l'Heure (BIH) in Paris, France. The BIH forms TAI from an average of more than one hundred atomic clocks located in many countries. The BIH initially synchronized TAI with UT2 at zero hours (midnight) January 1, 1958. Since that time TAI and UT2 have accumulated a difference of about 35 seconds (July 1, 1995). The difference is partly due to variations in the earth's spin, but mostly to the fact that atomic time was simply defined to run slightly faster than UT2. Even if TAI had been defined to have exactly the same rate as UT2 in the beginning (1958), it would soon begin to diverge, because TAI is very constant, while UT2 is always varying with the erratic earth's rotation.

During the past 37 years, two conflicting demands on standard time have developed. On one hand, science, communications systems, and electronic navigation systems have needed and exploited the extreme stabilities offered by atomic clocks. On the other hand, astronomy and celestial navigation still need time related to earth position, no matter how erratic it might be relative to atomic clocks.

Coordinated Universal Time (UTC)

To achieve a workable compromise between these two opposing demands, the Internal Radio Consultative Committee (CCIR) created a compromise time scale

called Coordinated Universal Time (UTC), which became effective January 1, 1972. On that date, the difference between TAI and UTC was 10 seconds. The rate of UTC is exactly the same as TAI. In fact, the “ticks” that mark the beginning of each second of TAI and UTC are precisely synchronous. However, the date of any given event on the UTC time scale must agree with its date on UT1 (not TAI or UT2) scale to within 0.9 seconds. Offsetting UTC from TAI by a precise, whole number of seconds accomplishes both requirements. In order to maintain the defined relationship between UT1 and UTC, a one-second correction, a leap second, is added to UTC as is required. As of January 1, 2000, UTC was 32 seconds behind TAI (the original 10 second difference plus the addition of 22 leap seconds in the intervening 18 years. However, since the earth continuously changes its rate of rotation, this time offset cannot be permanent. In order to keep UTC within 0.9 seconds of UT1, the BIH occasionally adds (or deletes) a second to (or from) the UTC scale, and every standard time system in the world follows suit. The CCIR recommended that these “leap seconds” should occur on the last day of June or the last day of December in any year in which a leap second is needed. Since the earth’s rotation rate is not perfectly predictable, scientists cannot forecast the need for a leap second more than a few months in advance. Leap seconds will be needed as long as the UTC time scale is used to keep UTC approximately in step with the sun. Otherwise, our clocks would gradually show the sun rising later and later until, after thousands of years, our clocks would indicate the sun was rising at noon.

Local Time

In most places local time differs from UTC by a whole number of hours, depending on the local time zone. The UTC time zone is GMT (or Zulu time in military terms). For example, you subtract five hours from UTC to get Eastern Standard Time (EST). From 2:00 a.m. on the first Sunday in April until 2:00 a.m. on the last Sunday in October, local time is advanced one hour (daylight saving time). Hence, only four hours are subtracted from UTC to get EDT.

Note

UTC is never advanced or retarded in observance of daylight saving time.

Formal Definitions of Time Interval

The Treaty of the Meter (which the United States signed in 1875) established an international organization to oversee and administer the International System of Units (i.e., the metric system). This international organization determines the definitions of the various units of measure, including the unit of time interval, the second.

Prior to 1956, the second was defined to be $1/86,400$ of a mean solar day (there are 86,400 seconds on one 24-hour day). From 1956 to 1967, the second was defined in terms of Ephemeris Time: $1/31,556,925.9747$ of the tropical year 1900. In 1967 atomic clocks took over the role of defining time interval. The new definition reads:

“The second is the duration of 9,192,631,770 periods of the radiation corresponding to the transition between the two hyperfine levels of the ground state of the cesium-133 atom.” (13th General Conference of Weights and Measures [CGPM] (1967), Resolution 1).

The definition of the International Atomic Time scale (TAI) incorporates the definition of the second.

The formal definition of TAI reads:

“International Atomic Time [TAI] is the time reference coordinate established by the Bureau International de l’Heure (BIH) on the basis of the readings of atomic clocks operating in accordance with the definition of the second, the time of the International System of Units.” (14th CGPM (1971), Resolution 1).

Accurate Time: A Summary

Local time typically differs from UTC by an integral number of hours, and UTC differs from TAI by an integral number of seconds. Since all standard time broadcasts use UTC by international agreement, almost the whole world runs on UTC. In many countries, the legal basis of “standard time” is UTC. Thus, from a legal point of view, accurate time must mean UTC, adjusted by the appropriate number of hours to give local time.

To a navigator on the oceans, however, accurate time really means UT1. UTC may be close enough (give or take 0.9 seconds)

for many navigators but, strictly speaking, navigators need UT1. To a scientist who doesn’t want to be bothered with leap seconds, accurate time means TAI.

So, in a very real sense, accurate time has different meanings to different people. The idea of accuracy relates to the use made of the time information. Fortunately, most of us do not need to bother with all these different time scales, since the time we get from the telephone, radio or television is adequate. If we trace the telephone, radio or television time back to its source, however, we would find that UTC is the master clock in our lives.

Introduction

In many applications involving the use of a digital clock or time code generator, the accuracy of timekeeping is not of paramount importance. In such cases, all that may be required is the ability to preset the clock to a time of day within a second or two of UTC time, or the user may want to simply accumulate elapsed time from some initial event. In many cases, very precise timekeeping is of extreme importance. Such may be the case whether the user desires to maintain exact time of day, or precise time from a given starting point. This section discusses two classes of digital clocks and time code generators using the general areas described above.

General Purpose Units: These units usually include a medium accuracy time base oscillator, usually a crystal oscillator (sometimes an oven-controlled crystal to provide improved stability).

Such units have the capability of being manually preset to a given time of day from the clock is then started. The starting time can be set to any value, including zero. This device usually includes a display of time that includes hours, minutes and seconds. Day of year is often included.

Precision Units: Precision timekeeping units differ from general purpose units in that they always operate from an external reference that is used to synchronize the unit. A synchronized time code generator will observe a serial time code input (e.g., IRIG B) and synchronize the crystal-driven generator to track the input code. This usually provides a precision of ± 2 microseconds or better relative to the source of the time code input.

DIGITAL CLOCK ACCURACY AND SYNCHRONIZATION

Another example of a precision unit would be a GPS synchronized time code generator. This unit gets precise time information from the Navstar/ GPS satellite system and can provide precision of better than ± 100 nanoseconds relative to UTC, as maintained by the US Naval Observatory.

Time Base Standards in Clocks

The degree of accuracy with which a digital clock can be expected to operate (in the absence of a reference input, such as time code or GPS data) is dependent on two prime considerations.

The first factor is that of time base accuracy and stability. This consideration is of importance whether the requirement is to maintain correct time of day or to accumulate elapsed time from an arbitrary reference point.

The second factor is that of synchronization to an external time standard. This consideration is of prime importance when maintaining time of day. Such synchronization is normally not involved when accumulating elapsed time.

The reference for nearly all working time standards is based upon a defined frequency standard. Since time is the direct reciprocal of frequency, the two are directly interchangeable and the availability of reliable frequency makes them ideal as a time base for digital clocks and time code generators.

Cesium Beam Standards (CS)

Although other atomic frequency standards have been developed and are commercially available today, the cesium beam (Cs) was selected as the primary standard for its accuracy and longterm stability. Most commercially available cesium beam standards are capable of producing a frequency to an accuracy of a few parts in 10^{-12} .

These devices can maintain this accuracy over the life of the cesium tube. The fre-



Cs4000 Cesium Frequency Standard

quency stability of the device with measurement times from one day to as much as a year does not vary more than a few parts in 10^{-13} of its nominal value. A cesium beam standard is an expensive device, but in those instances where autonomous frequency accuracy (i.e., with no external reference) for long intervals is required, the cesium beam standard is the only practical choice.

Hydrogen Maser

The hydrogen maser exhibits the best short and long-term stability of any standard yet developed. The inherent accuracy of this device is not great compared to the cesium beam. Hydrogen masers are not likely to become a primary frequency source unless the accuracy can be improved and the cost can be substantially reduced. The extremely high price of the hydrogen maser limits its use to only the most sophisticated applications requiring ultimate stability. The principal areas of application of the hydrogen maser is Very Long Baseline Interferometry (VLBI), deep space probes and metrology applications.

Rubidium Standard (Rb)

The rubidium frequency standard finds many applications in modern time and frequency management systems. The rubidium standard is built in a much smaller package than the cesium beam. The characteristics of the rubidium standard, however, are significantly different from that of the cesium beam. One reason that this

atomic standard was not selected as a primary standard was an inherent frequency drift (approximately 1 part in 10^{-11} per month for most commercial devices). The rubidium is generally selected for applications in which the quartz crystal oscillator does not provide adequate long-term stability, and cost and size considerations restrict the use of cesium beam standards. The rubidium has excellent retrace characteristics (return to the frequency of interest after a cold start) and warms up to its nominal frequency in a matter of minutes. The reliability of modern rubidium is sufficient with user reporting in excess of five years of uninterrupted operation. The rubidium's characteristics have made it an excellent choice for many precision navigation receiver applications requiring high-stability internal oscillators. It also has found applications in metrology laboratories and communication systems.

Quartz Oscillators

The crystal oscillator has a number of qualities which make its use as a reliable frequency standard desirable. When certain crystals are subjected to mechanical stress, they will produce an electrical potential across opposite faces and, conversely, when placed within an electric field, these crystals will be stressed or deformed in proportion to the strength of the field. This electromechanical relationship is known as the piezoelectric effect.

Of all crystalline materials, quartz exhibits the best oscillator characteristics. It has

mechanical stability and is relatively immune to external environmental conditions. When connected into a closed loop electric circuit in such a manner as to sustain oscillations and control the frequency of oscillation, the quartz oscillator provides a convenient and reliable frequency source and time base for clocks and time code generators. Almost all atomic standards incorporate quartz crystal oscillators as an essential element.

Sources of Oscillator Error

All crystal oscillators exhibit resonant frequency changes. Obviously, since a clock requires a linear time base for accurate timekeeping, any frequency change in the time base will introduce error into the time reading. Frequency changes within a quartz oscillator are attributable to two major causes: frequency offset and oscillator aging.

Frequency offset is merely the frequency error that exists when the clock is initially set. This is most likely due to oscillator aging since the last time the oscillator was calibrated, but it is a fixed offset in the error calculation for any given time period. Oscillator aging is the inherent frequency change due to small physical changes in the crystalline structure. This factor is called either drift or aging, and is defined as a frequency change over a given period of time. In all quartz oscillators, this aging rate is very pronounced during the initial operating period, after which it becomes relatively constant. Quartz oscillators are available with aging rates from 1 part in 10^{-4} per day to better than 1 part in 10^{-11} per day. The aging characteristics are, in general, a result of the quality of the raw quartz, the type of cut, the manufacturing process, and the aging process allowed by the manufacturer.

The equation for total time error is:

$$E = E_o + \left(\frac{f_o}{f_r} - 1 \right) t + \frac{at^2}{2}$$

The total time error (**E**) over any period of time (**t**) depends upon four variables. Where ...

E_o is the initial time error

f_o is the initial frequency setting (offset)

f_r is the reference setting (ideal frequency)

a is the oscillator aging rate

t is the elapsed time in seconds

Note

Set **t** to 86,400 for the daily aging rate of a crystal oscillator.

The frequency change of the oscillator is assumed to be linear in an ever increasing value. The time error increases exponentially as the frequency of the oscillator drifts. If an oscillator is set precisely to coincide with the reference oscillator, frequency offset (**f_r**) is zero and the total time error will be a result only of the aging of the oscillator. An offset error will vary the time error on a linear basis.

The nomograph shown on the following page can be used as an aid to estimate the time error accumulated over a period of time due to aging and frequency offset of a crystal oscillator. In accordance with the above equation, the two error values are added to determine the total error for any given condition.

Setting the Clock

If the purpose of the time code generator is merely to keep track of a sequence of events in a given test, then setting the clock to a precise external reference is not very important. However, if the time code generator must provide time information that is to be correlated with data collected at a different location, then both clocks must agree. In the second case, setting the clocks to a common time scale (probably UTC) is not only desirable but necessary. Several methods have been devised to accomplish this task.

WWV, WWVH, WWVB Time Synchronization

The National Institute of Standards and Technology (NIST) maintains three radio stations whose function it is to transmit standard time broadcasts for users throughout the world. Radio stations WWV in Colorado and WWVH in Hawaii are high frequency broadcast stations on carrier frequencies of 2.5 MHz, 5 MHz, 10 MHz and 20 MHz. WWV additionally transmits on 25 MHz. In addition to the two high frequency radio stations, radio station WWVB in Colorado broadcasts serial time code at 60



8130A Militarized Rubidium Oscillator

kHz carrier for accurate frequency measurements within the continental United States.

Radio stations WWV and WWVH have, in addition to serial time codes, voice time announcements and other special voice announcements, as well as various tone signals. Finally, a one-second "tick" is also broadcast from both stations for audio determination of the 1 PPS "epoch." This tick is used to start a time code generator by first listening to the voice time announcement and setting the time of the generator to the beginning of the next minute. Then, when the time approaches the top of the minute, the local operator will arm the generator to use the tick to start counting. This technique will start a time code generator within one or two milliseconds of UTC. By using a dual trace oscilloscope and an advance/retard function (if it is included in the generator), one can approach UTC to within 100 microseconds, provided that the signal propagation time from the radio station to the user's location is well known.

Since the carrier frequency of WWVB is low (60 kHz), the propagation delay remains relatively constant and may be more accurately calculated compared to WWV and WWVH which have varying transmission paths due to atmospheric considerations. A time code with a one-minute time frame is transmitted on WWVB that will provide an accuracy of about 5 milliseconds.

Loran C

The Loran C (LONg RANGE Navigation) system has been used by time and frequency users for a variety of reasons. All Loran stations are equipped with triple redundant cesium beam frequency standards. The

time at every Loran station is periodically calibrated by the US Naval Observatory. A Loran C receiver that is specifically designed to provide precise time and frequency can produce frequency accuracy that is within 1 part in 10 and a time reference that is always within ± 500 nanoseconds of UTC. The biggest problem associated with using Loran C as a time and frequency reference is that it is a coastal system, intended to provide navigation support to ships at sea. Loran does not transmit any time scale information, so a local time code generator must be manually preset to a time, and then kept in synchronization by the time base frequency and 1 PPS epoch derived from the Loran broadcast.

Geostationary Operational Environmental Satellite (GOES)

The GOES satellites are used to take photographs of the earth for the study and forecasting of weather, for mapping information, and collecting data from several hundred instrumentation platforms spread throughout their coverage area. The satellites are at an altitude of 36,000 kilometers, which give them an orbital period of exactly 24 hours, thus they appear to be fixed in space at one location. A time code message is transmitted from a master clock on the ground at Wallops Island, Virginia up to the satellites. Because of the length of the path, NIST has elected to advance transmission of the time code message by approximately 260 milliseconds prior to transmission from Wallops Island. Thus, GOES timing receiver may actually receive the time code early. In order to provide a precise time code output, a GOES receiver must compensate for the propagation delay from Wallops Island to the satellite and back to the user's location. The best precision that one can expect to obtain with a GOES receiver is about ± 10 microseconds. The time scale used by GOES is UTC.

Transit (Navy Navigation Satellite System, NNSS)

The Transit system is a constellation of five satellites, all in circular polar orbits, designed to support navigation of ships at sea. The orbital altitude is about 600 miles, providing an orbital period of approximately 107 minutes. Commercial equipment has

been made for this system, but it has never gained wide acceptance as a timing system. Transit was designed for a timing accuracy of 500 milliseconds, although users have reported a precision of 50 microseconds or better. The operator must manually enter time within ± 15 minutes of UTC in order to begin the acquisition and tracking process. Timing accuracy at any user's location is dependent largely on the stability of the oscillator in the receiver, since a satellite remains in view only for about 20 minutes for each pass.

Global Positioning System (GPS)

The GPS system provides the ultimate in accuracy to both the navigator and timing user. The GPS satellite constellation comprises four satellites in each of six orbital planes for a total of 24 satellites. This system provides continuous worldwide coverage for navigational as well as for time/frequency users. By observing a minimum of four satellites simultaneously, a GPS receiver can automatically determine its own location by triangulation. Each satellite transmits a database of information that includes (among other data) a precise almanac that details the orbital details for

accuracy of the navigational solution that the time and frequency of these devices be controlled to the maximum extent possible. A one nanosecond error in timing represents about one foot in navigational error. Both the US Naval Observatory and the US Air Force at Falcon AFB, Colorado monitor each satellite daily. Corrections are uploaded to every satellite as a result of these measurements. A user's GPS receiver applies this correction measured data to produce precise corrected outputs of time and frequency. The GPS satellite operates on a GPS time scale, which is a continuous time scale (like UT1). The satellite transmits information about the number of leap seconds that must be added to convert GPS time to UTC.

The GPS satellites are in circular orbits at an altitude of about 19,650 kilometers. At this altitude, the satellites circle the earth twice each day (on the sidereal clock). Because the orbital period is based on sidereal time (not solar time), the satellites appear approximately 4 minutes early each day.

Symmetricom commercial GPS Time & Frequency Generators operate on the L1 frequency (1.57542 GHz) and use the CA (coarse acquisition) code. For authorized



XLI GPS Time and Frequency System

every satellite. A GPS receiver can measure the difference in arrival of the satellite signals from all satellites and thus determine their distance, which allows position to be determined.

Naturally, this equation requires accurate time, since the satellites are all in constant motion. Once the user's position has been determined, a precise time transfer can be accomplished, with the time at the user's location corrected to within ± 100 nanoseconds relative to the 1 PPS epoch maintained by the US Naval Observatory.

Every GPS satellite carries a cesium beam frequency standard. It is essential to the

military users, Symmetricom offers Selective Availability Anti-Spoofing Module (SAASM) based GPS Time & Frequency Receivers which utilize the P(Y) code that operate on both the L1 and L2 (1.2276 GHz) frequencies. P(Y) code is encrypted and requires a SAASM based GPS receiver to decrypt and use the information. Due to the strong security technology offered by SAASM, the Joint Chiefs of Staff mandated the use of SAASM based GPS Receivers by military personnel effective October 2002. The dual band P(Y) signal is also extremely difficult to jam.

While processing satellite data normally, a timing GPS receiver will produce precise



MarkV GPS P(Y) Code Time & Frequency Receiver

time and frequency outputs, regardless of the quality of the internal time base oscillator, because it is being continuously corrected from GPS data. If the receiver is deprived of satellite data, however, the stability of the internal oscillator is the only factor that determines the amount of time error that will develop over time. Symmetricom GPS Time & Frequency Generators can be equipped with a basic TCXO crystal, a high-stability oven oscillator or a rubidium oscillator. Each will provide increasing better stability in the absence of satellite data. All will provide the same time precision of 30 nanoseconds RMS while processing satellite data.

While the internal operation of a GPS receiver is extremely complex, the user will find it to be the simplest system for time and frequency purposes. The reason is that the GPS system is completely self-contained and makes all necessary corrections automatically. A Symmetricom GPS Time & Frequency Generator need only to be turned on and allowed to run.

Selection and Use of Time Code

Formats Coded time signals, commonly called "time code formats," some of which are contained in this document, are primarily used to provide time correlation of multiple data sources and multiple data points during monitoring or recording of various types of data. Precise time, related to world-wide time scales, is of critical importance in monitoring spaceship launching and tracking activities. Time intervals, rather than world-wide time, are important in monitoring processes: flight test, weapons test, medical research, etc. Time, when recorded with data, serves as a convenient means of correlating various types of data recorded on different media. Time also becomes a convenient reference for data retrieval should analysis of a

recording be desired in the future.

Selecting a time code format involves evaluation of the accuracy and data resolution being recorded, as well as an evaluation of the specific recording medium. The bandwidth of the recording device governs the rate of the time code format and, therefore, its resolution. The accuracy of the time and time code format depends primarily on the source of the time code and its relationship to world-wide time or on the accuracy of its individual frequency sources. Thus, various time codes are defined at different rates and different resolutions.

Time code formats have been defined to support such high speed data acquisition



TymMachine 7000

as camera instrumentation and telemetry. Other formats have been defined to support very low speed data acquisition methods such as oscillographs and strip chart recorders.

When the time code format is to be transmitted or when the specific recording device requires signal conditioning, additional characteristics are usually incorporated. Most common is the use of a sine wave carrier, amplitude modulated by the time code format. This permits the signal to be conveniently transmitted by means of a conventional telephone circuit or by being recorded on low bandwidth magnetic tape recorders.

Inter Range Instrumentation Group (IRIG) Time Code Formats

In the early 1950's it became apparent that efficient interchange of test data between the various test ranges and laboratories would require time code standardization. This task of standardization was assigned to the TeleCommunications Working Group (TCWG) of the IRIG in October 1956. The original IRIG standards were accepted by the steering committee in 1960. IRIG Document 104-60 defined the original IRIG formats. This document was later revised and then reprinted in August 1970 as IRIG Document 104-70. Later in 1970 the status of the IRIG Document was upgraded to that of a Standard, and republished as IRIG Standard 200-70. As of this writing, the latest publication is IRIG Standard 200-95. A copy of the latest version can be obtained at no cost by writing a request to the Secretariat, Range Commander's Council, White Sands Missile Range, New Mexico, 88002.

Description of IRIG Formats

In the IRIG family, individual time code formats are alphabetically designated as A, B, D, E, G and H. These are all defined in IRIG Standard 200-95. IRIG C format was originally defined as a one-minute time code in IRIG Document 104-60, but was subsequently replaced by IRIG H. Various signal forms are defined in IRIG Standard 20-95. The following identification is taken from the IRIG Standard 200-95.

Rate Designation:

- A) 1,000 PPS
- B) 100 PPS
- D) 1 PPM
- E) 10 PPS
- G) 10,000 PPS
- H) 1 PPS

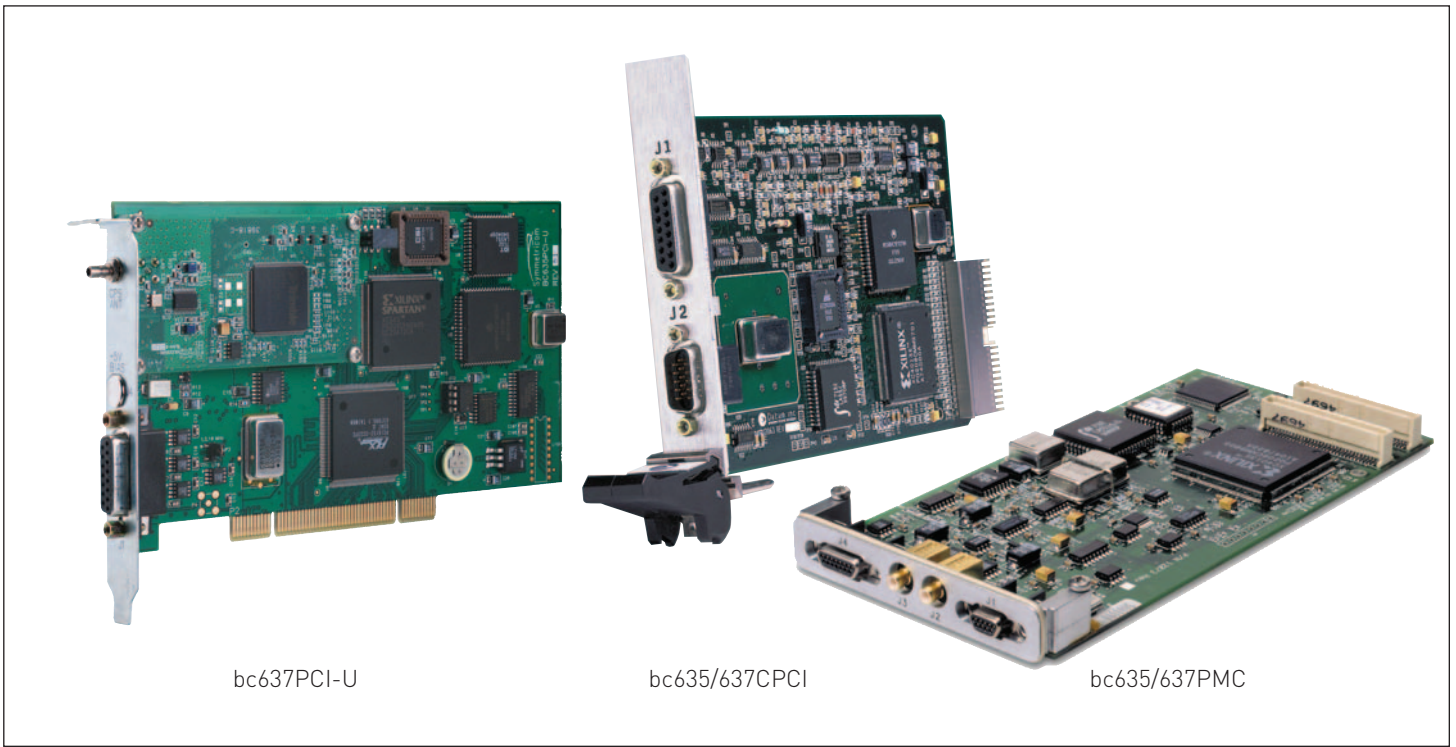

bc637PCI-U

bc635/637CPCI

bc635/637PMC

PCI Family of Time & Frequency Processors

Form Designation:

- 0) DCLS (width coded)
- 1) Sine wave carrier (amplitude modulated)

Carrier Resolution:

- 0) No carrier (DCLS)
- 1) 100 Hz (10 mS resolution)
- 2) 1 kHz (1 mS resolution)
- 3) 10 kHz (100 S resolution)
- 4) 100 kHz (10 S resolution)
- 5) 1 MHz (1 S resolution)

Coded Expressions:

- 0) BCD, CF, SBS
- 1) BCD, CF
- 2) BCD
- 3) BCD, SBS

The following signal combinations are recognized in accordance with IRIG Standard 200-95.

IRIG A	IRIG B	IRIG D	IRIG E	IRIG G	IRIG H
A000	B000	D001	E001	G001	H001
A003	B003	D002	E002	G002	H002
A130	B120	D111	E111	G141	H111
A132	B122	D112	E112	G142	H112
A133	B123	D121	E121		H121
	B150	D122	E122		H122
	B152				
	B153				

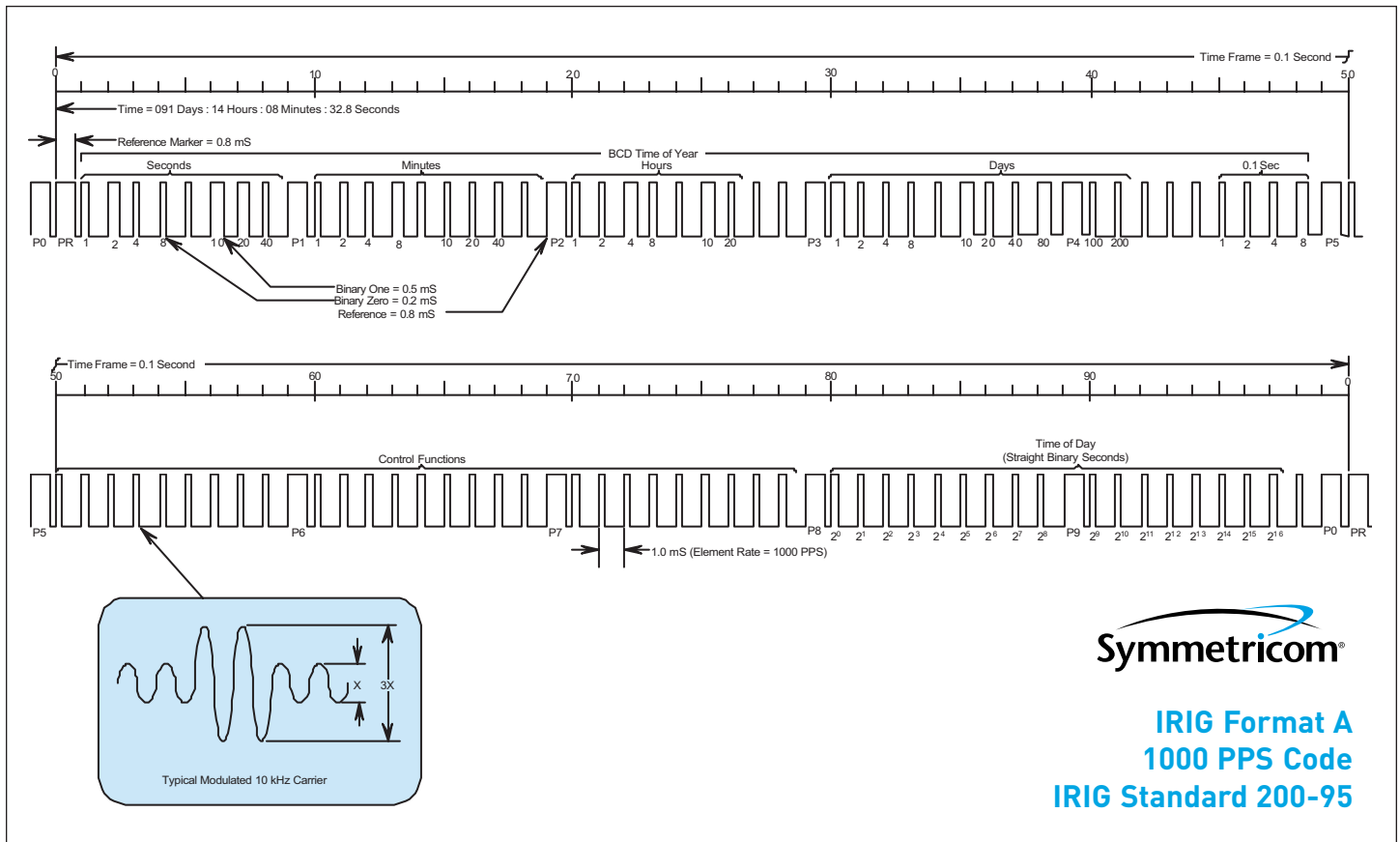

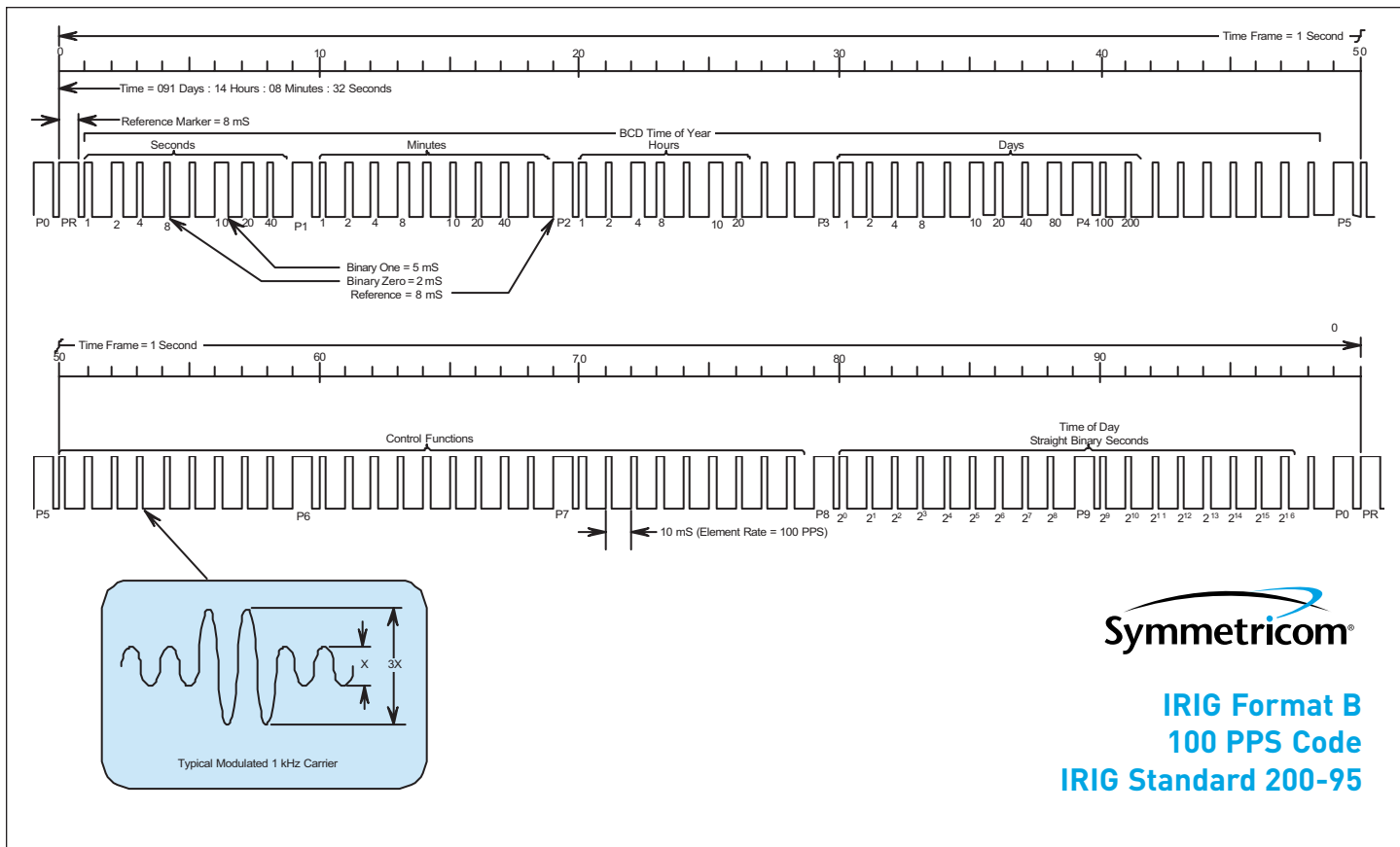

IRIG Format A
1000 PPS Code
IRIG Standard 200-95

- 1. Time Frame:** 0.1 second.
- 2. Code Digit Weighting Options:** BCD, SBS or both.
 - a. BCD time of year code word - 34 bits.
 - 1) Seconds, minutes, hours, days and 0.1 seconds, recycle yearly.
 - b. Straight binary seconds (SBS) - 17 bits.
 - 1) Seconds time of day, recycles daily (count: 00000 - 86399).
- 3. Code Word Structure:**
 - a. BCD: Word begins at Index Count 1. BCD bits occur between Position Identifier Elements (7 for seconds, 7 for minutes, 6 for hours, 10 for days, 4 for tenths of seconds) until the code word is complete. A Position Identifier occurs between decimal digits in each group to provide separation for visual resolution.
 - b. SBS: Word begins at Index Count 80. Seventeen binary bits occur with a Position Identifier between the 9th and 10th bits. This is a pure binary integer representing seconds since midnight.
- 4. Least Significant Digit:** Occurs first, except for fractional seconds digit, which occurs following the hundreds of days digit.
- 5. Element Rates Available:**
 - a. 1,000 PPS (basic element rate)
 - b. 100 PPS (Position Identifier rate).
 - c. 10 PPS (Frame rate).
- 6. Element Identification:**
 - a. On-Time is the leading edge of a pulse.
 - b. Index Marker: 0.2 mS (zero or uncoded bit).
 - c. Code Digit: 0.5 mS (one).
 - d. Position Identifier: 0.8 mS.
 - e. Reference Marker: Two consecutive Position Identifiers.
- 7. Resolution:** 1 mS (DCLS), 0.1 mS (modulated carrier).
- 8. Carrier Frequency:** 10 kHz (when modulated).

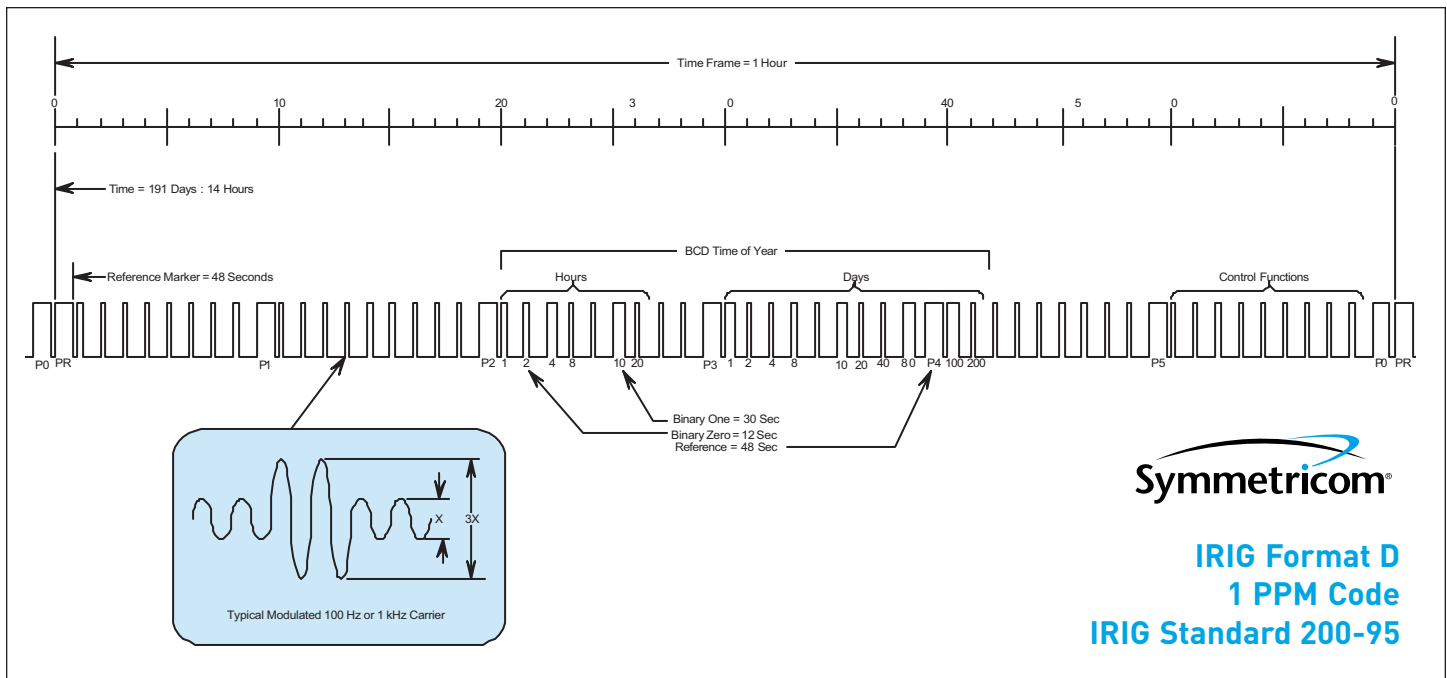

IRIG Format B
100 PPS Code
IRIG Standard 200-95

- 1. Time Frame:** 1 second.
- 2. Code Weighting Options:** BCD, SBS or both.
 - a. BCD time of year code word - 30 bits.
 - 1) Seconds, minutes, hours and days, recycle yearly.
 - b. Straight binary seconds (SBS) - 17 bits.
 - 1) Seconds time of day, recycles daily (count: 00000 - 86399).
- 3. Code Word Structure:**
 - a. BCD: Word begins at Index Count 1. BCD bits occur between Position Identifier Elements (7 for seconds, 7 for minutes, 6 for hours, 10 for days) until the code word is complete. A Position Identifier occurs between decimal digits in each group to provide separation for visual resolution.
- 4. Least Significant Digit:** Occurs first.
- 5. Element Rates Available:**
 - a. 100 PPS (basic element rate)
 - b. 10 PPS (Position Identifier rate).
 - c. 1 PPS (Frame rate).
- 6. Element Identification:**
 - a. On-Time is the leading edge of a pulse.
 - b. Index Marker: 2 mS (zero or uncoded bit).
 - c. Code Digit: 5 mS (one).
 - d. Position Identifier: 8 mS.
 - e. Reference Marker: Two consecutive Position Identifiers.
- 7. Resolution:** 10 mS (DCLS), 1 mS (modulated carrier); 1 μ S (1 MHz modulated carrier).
- 8. Carrier Frequency:** 1 kHz or 1 MHz (when modulated).



1. Time Frame:

1 hour.

2. Code Weighting Options:

BCD only.

- a. BCD time of year code word -16 bits.
 - 1) Hours and days, recycle yearly.

3. Code Word Structure:

- a. BCD: Word begins at Index Count 20. BCD bits occur between Position Identifier Elements (6 for hours, 10 for days) until the code word is complete. A Position Identifier occurs between decimal digits in each group to provide separation for visual resolution.

4. Least Significant Digit:

Occurs first.

5. Element Rates Available:

- a. 1 PPM (basic element rate)
- b. 0.1 PPM (Position Identifier rate).
- c. 1 PPH (Frame rate).

6. Element Identification:

- a. On-Time is the leading edge of a pulse.
- b. Index Marker: 12 Sec (zero or uncoded bit).
- c. Code Digit: 30 Sec (one).
- d. Position Identifier: 48 Sec
- e. Reference Marker: Two consecutive Position Identifiers.

7. Resolution:

1 Minute (DCLS), 10 mS (modulated 100 Hz carrier);
1 mS (modulated 1 kHz carrier).

8. Carrier Frequency:

100 Hz or 1 kHz (when modulated).

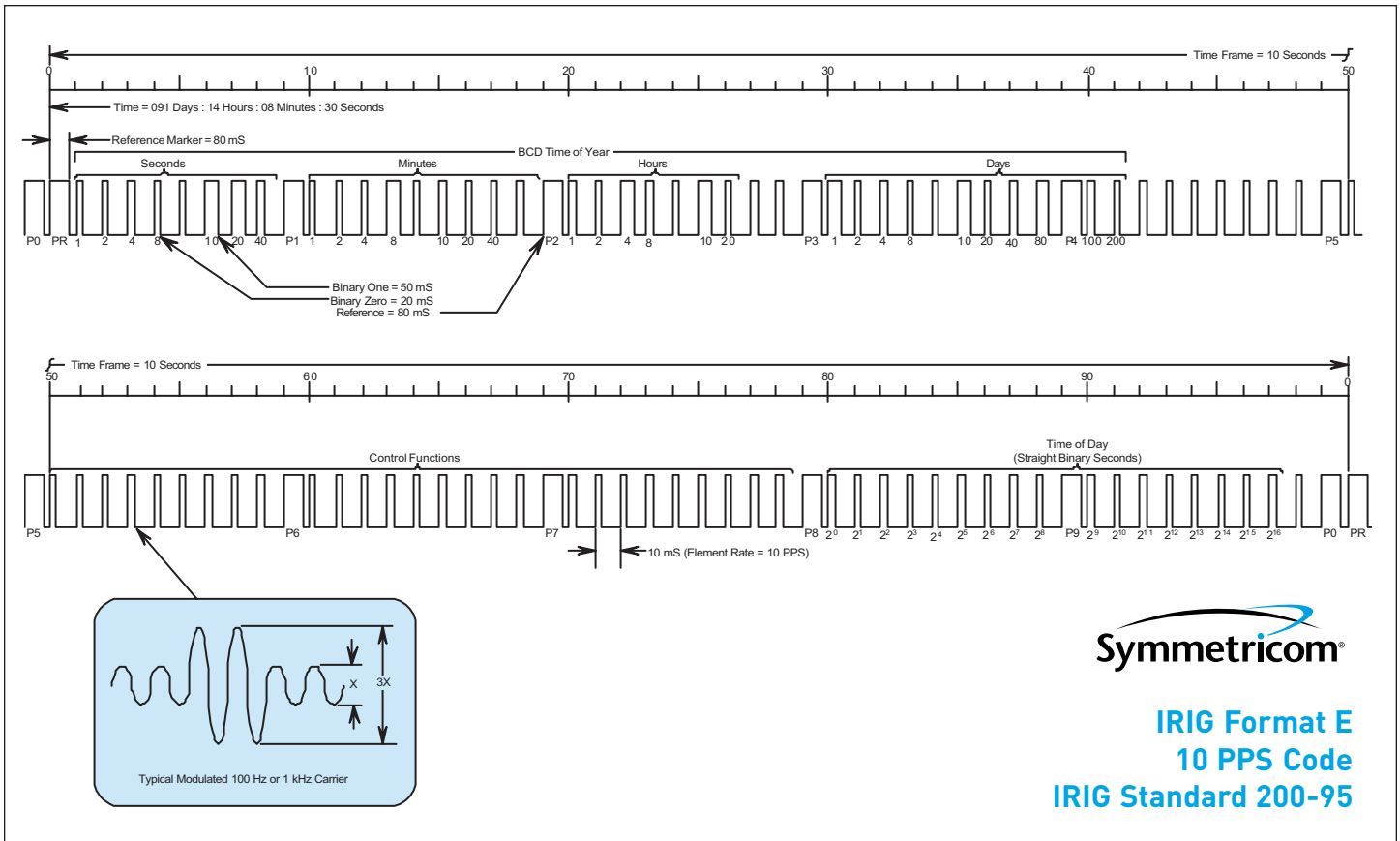

1. Time Frame: 10 Seconds.

2. Code Weighting Options:

BCD only.

a. BCD time of year code word - 26 bits.

1) Seconds, minutes, hours and days, recycle yearly.

3. Code Word Structure:

a. BCD: Word begins at Index Count 6. BCD bits occur between Position Identifier Elements (3 for seconds, 7 for minutes, 6 for hours, 10 for days) until the code word is complete. A Position Identifier occurs between decimal digits in each group to provide separation for visual resolution.

4. Least Significant Digit:

Occurs first.

5. Element Rates Available:

- a. 10 PPS (basic element rate)
- b. 1 PPS (Position Identifier rate)
- c. 0.1 PPS (Frame rate)

6. Element Identification:

- a. On-Time is the leading edge of a pulse.
- b. Index Marker: 20 mS (zero or uncoded bit).
- c. Code Digit: 50 mS (one)
- d. Position Identifier: 80 mS
- e. Reference Marker (1 per 10 seconds): Two consecutive Position Identifiers.

7. Resolution:

100 mS (DCLS), 10 mS (modulated 100 Hz carrier); 1 mS (modulated 1 kHz carrier)

8. Carrier Frequency:

100 Hz or 1 kHz when modulated)

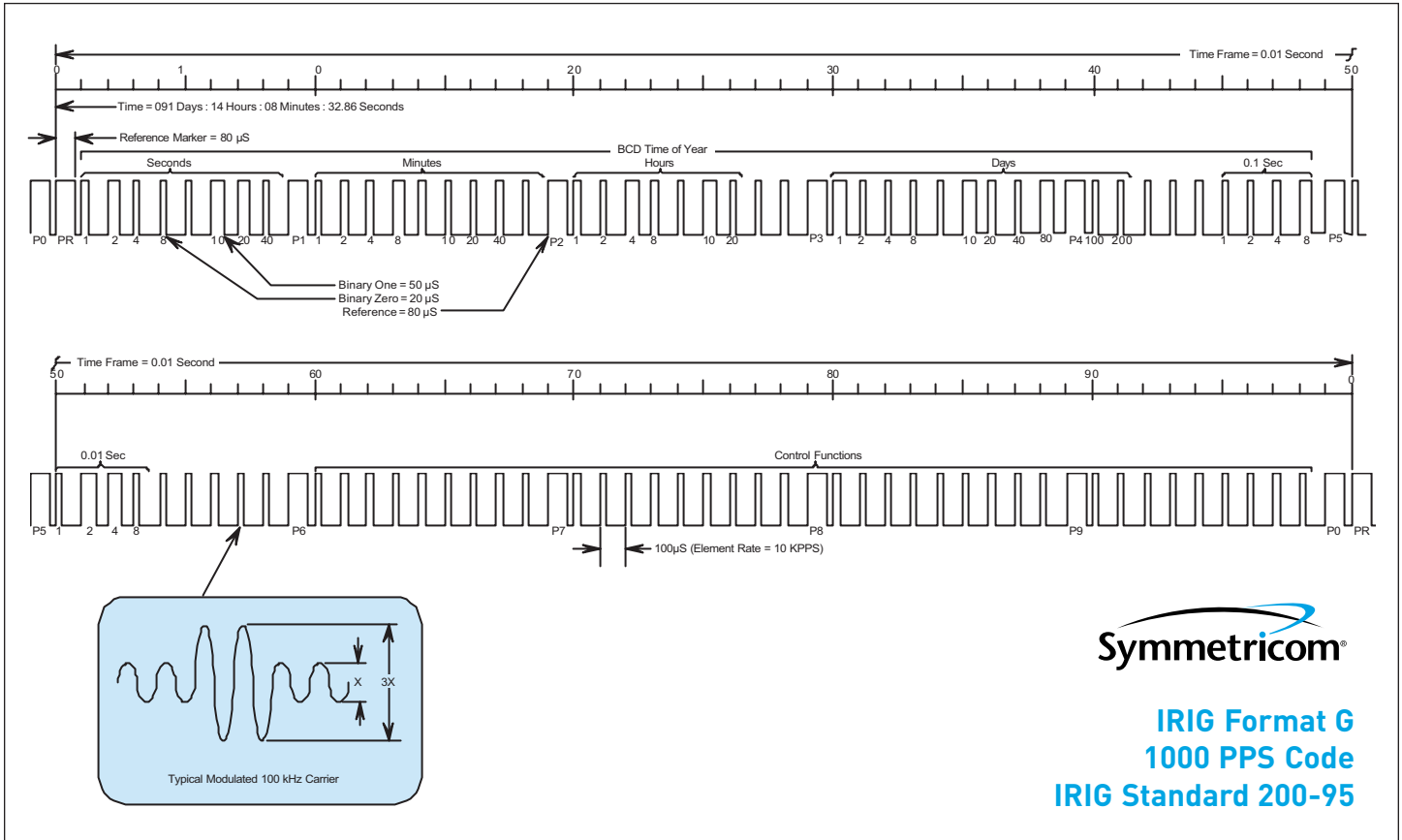

1. Time Frame:
0.01 second.

2. Code Weighting Options:
BCD only.

- a. BCD time of year code word - 38 bits.
 - 1) Seconds, minutes, hours, days, 0.1 seconds and 0.1 seconds, recycle yearly.

3. Code Word Structure:

- a. BCD: Word begins at Index Count 1. BCD bits occur between Position Identifier Elements (7 for seconds, 7 for minutes, 6 for hours, 10 for days, 4 for tenths of seconds, 4 for hundredths of seconds) until the code word is complete. A Position Identifier occurs between decimal digits in each group to provide separation for visual resolution.

4. Least Significant Digit: Occurs first, except for fractional seconds digits, which occur following the hundreds of days digit.

5. Element Rates Available:

- a. 10,000 PPS (basic element rate).
- b. 1,000 PPS (Position Identifier rate).
- c. 100 PPS (Frame rate).

6. Element Identification:

- a. On-Time is the leading edge of a pulse.
- b. Index Marker: 0.02 mS (zero or uncoded bit).
- c. Code Digit: 0.05 mS (one).
- d. Position Identifier: 0.08 mS.
- e. Reference Marker: Two consecutive Position Identifiers.

7. Resolution: 0.1 mS (DCLS), 0.01 mS (modulated carrier).

8. Carrier Frequency:
100 kHz (when modulated).

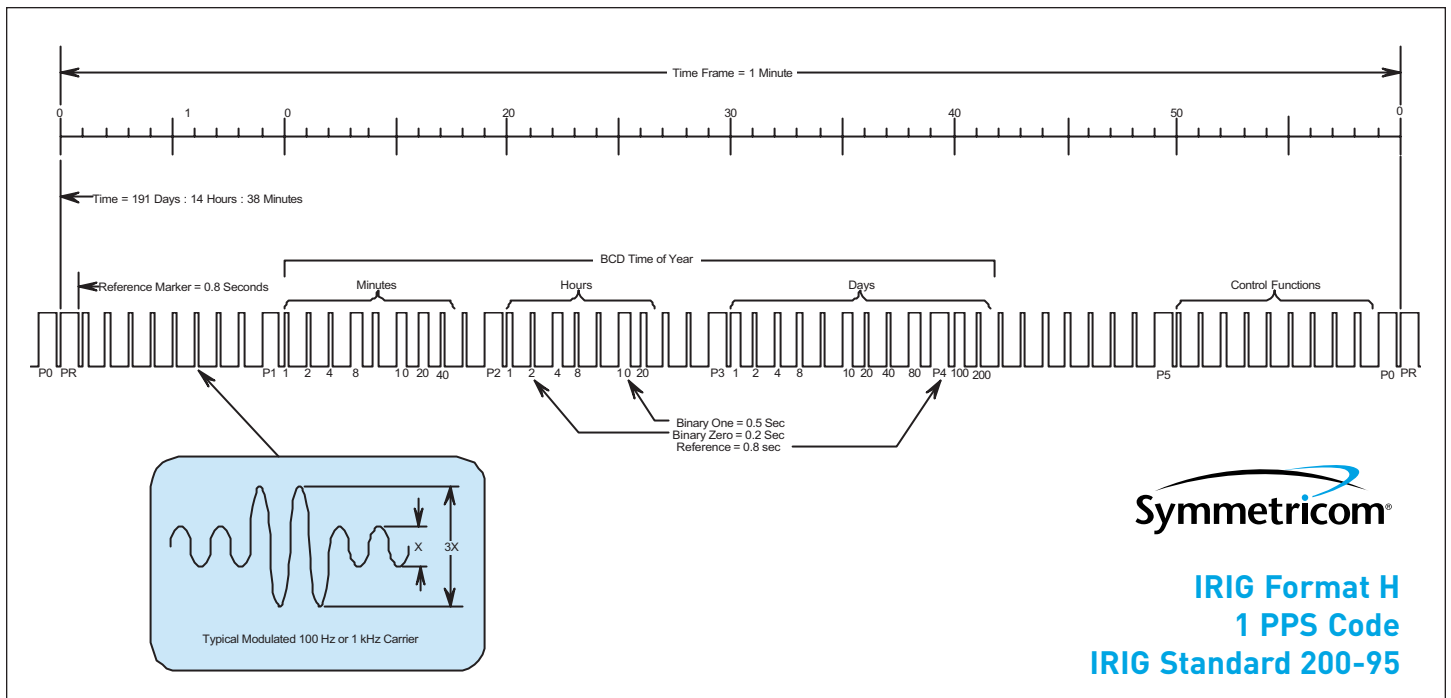

1. Time Frame:

1 minute.

2. Code Weighting Options:

BCD only.

- a. BCD time of year code word - 23 bits. Minutes, hours and days, recycle yearly.

3. Code Word Structure:

- a. BCD: Word begins at Index Count 10. BCD bits occur between Position Identifier Elements (7 for minutes, 6 for hours, 10 for days) until the code word is complete. A Position Identifier occurs between decimal digits in each group to provide separation for visual resolution.

4. Least Significant Digit:

Occurs first.

- a. 1 PPS (basic element rate)
- b. 0.1 PPS (Position Identifier rate).
- c. 1 PPM (Frame rate).

6. Element Identification:

- a. On-Time is the leading edge of a pulse.
- b. Index Marker: 0.2 Sec (zero or uncoded bit).
- c. Code Digit: 0.5 Sec (one)
- d. Position Identifier: 0.8 Sec
- e. Reference Marker: Two consecutive Position Identifiers.

7. Resolution:

1 Sec (DCLS), 10 mS (modulated 100 Hz carrier); 1 mS (modulated 1 kHz carrier).

8. Carrier Frequency:

100 Hz or 1 kHz (when modulated).



**IRIG Format H
1 PPS Code
IRIG Standard 200-95**

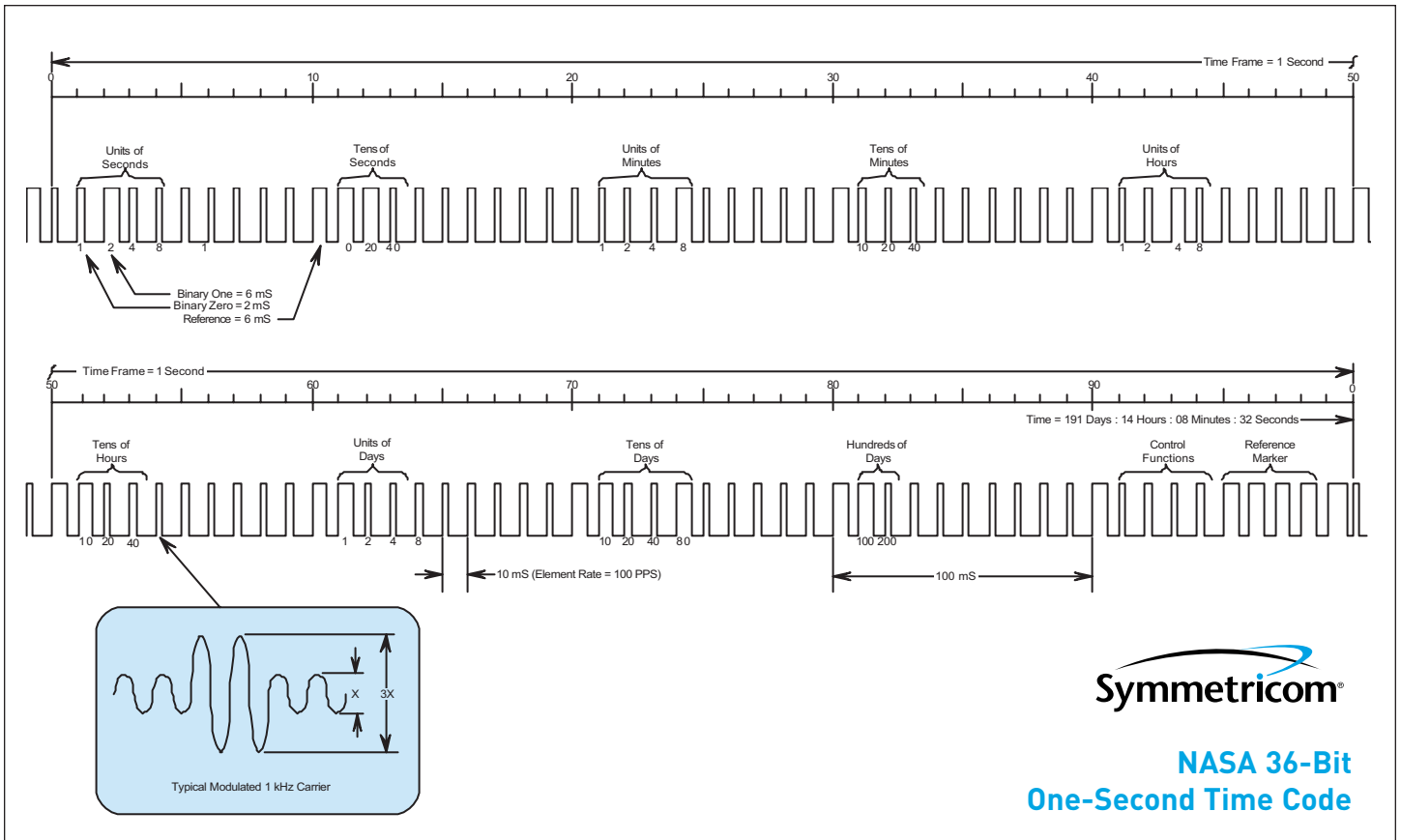

**NASA 36-Bit
One-Second Time Code**

1. Time Frame:

1 second.

2. Code Weighting Options:

BCD

- a. BCD time of year code word - 30 bits. 1) Seconds, minutes, hours and days, recycle yearly.

3. Code Word Structure:

- a. BCD: Word begins at Index Count 1. BCD elements occur between Position Identifier Elements in four-bit groups until the code word is complete. A Code Digit occurs between decimal digits in each group to provide separation for visual resolution.

4. Least Significant Digit:

Occurs first.

5. Element Rates Available:

- a. 100 PPS (basic element rate)
- b. 1 PPS (Frame rate)

6. Element Identification:

- a. On-Time is the leading edge of a pulse.
- b. Index Marker: 2 mS (zero or uncoded bit).
- c. Code Digit: 6 mS (one)
- d. Position Identifier: 6 mS (same as one).
- e. Reference Marker: Five consecutive Position Identifiers followed by an Index Marker.

7. Resolution:

10 mS(DCLS), 1 mS (modulated carrier).

8. Carrier Frequency:

1 kHz (when modulated).

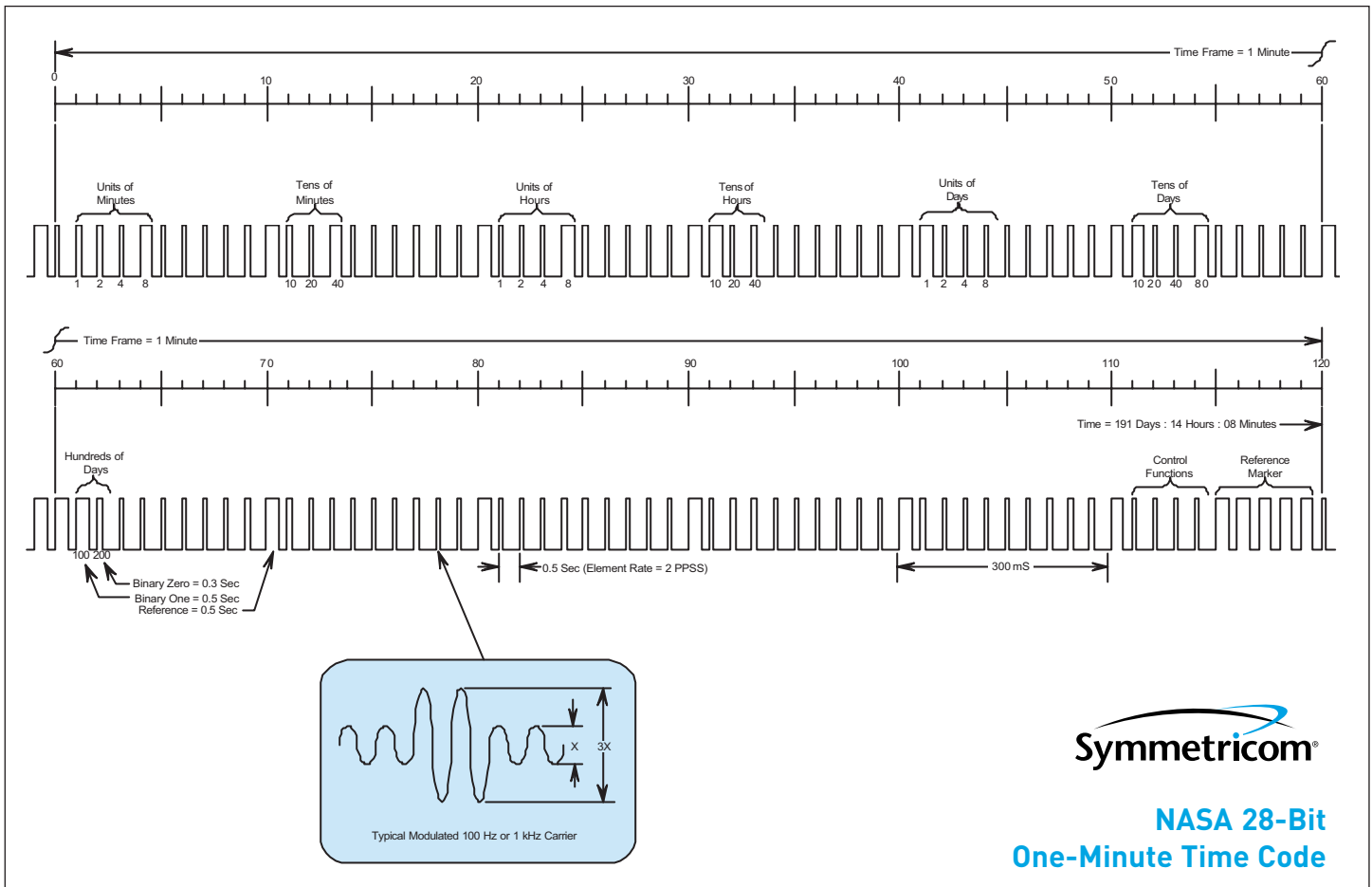

1. Time Frame: 1 minute.

2. Code Weighting Options: BCD

- a. BCD time of year code word - 23 bits. Minutes, hours and days, recycle yearly.

3. Code Word Structure: BCD:

Word begins at Index Count 1. BCD elements occur between Position Identifier Elements in four-bit code groups until the code word is complete. A Code Digit occurs between decimal digits in each group to provide separation for visual resolution.

4. Least Significant Digit:

Occurs first.

5. Element Rates Available:

- a. 2 PPS (basic element rate)
- b. 1 PPM (Frame rate)

6. Element Identification:

- a. On-Time is the leading edge of a pulse.
- b. Index Marker: 100 mS (zero or uncoded bit).
- c. Code Digit: 300 mS (one)
- d. Position Identifier: 300 mS (same as one)
- e. Reference Marker: Five consecutive Position Identifiers followed by an Index Marker.

7. Resolution: 0.5 Sec (DCLS), 10 mS (modulated 100 Hz carrier); 1 mS (modulated 1 kHz carrier)

8. Carrier Frequency: 100 Hz or 1 kHz when modulated).

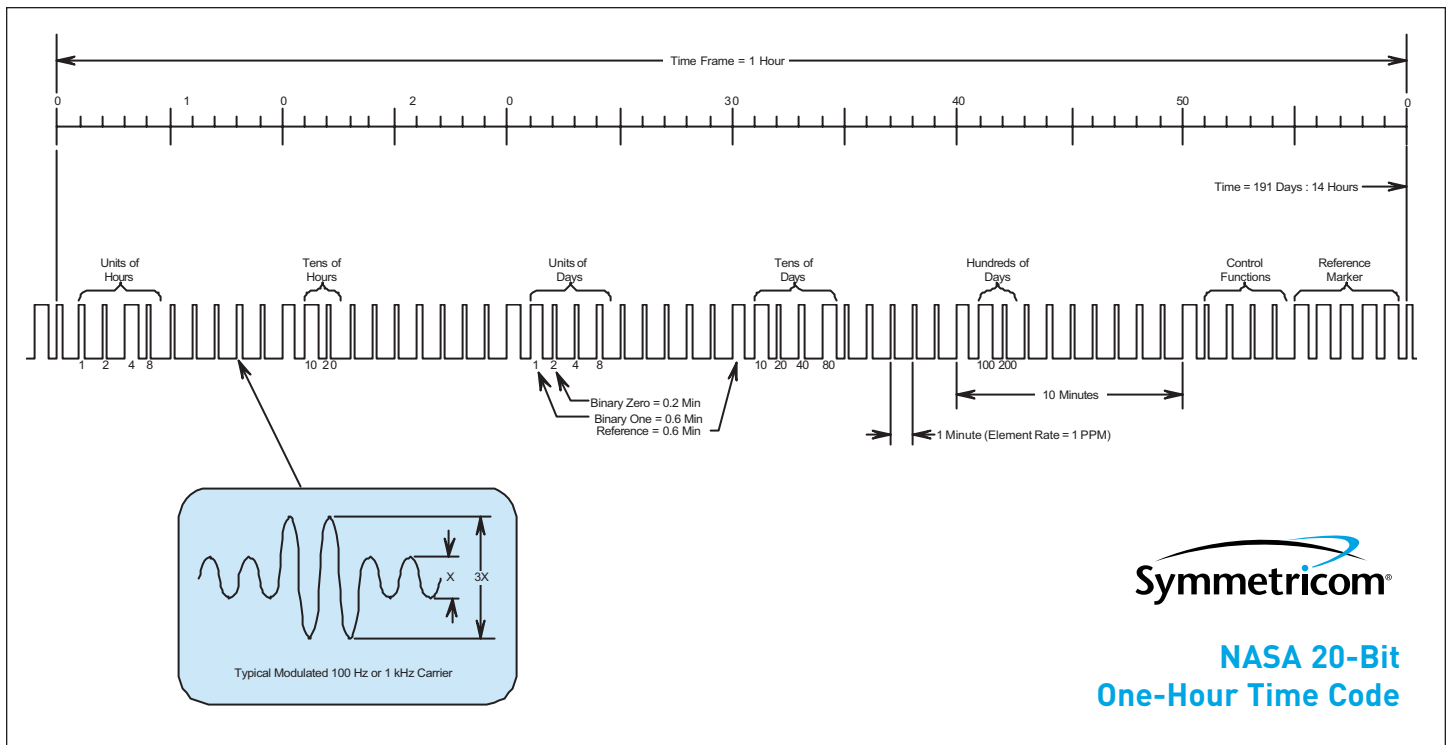

1. Time Frame:

1 hour.

2. Code Weighting Options:

BCD

a. BCD time of year code word - 16 bits. Hours and days, recycle yearly.

3. Code Word Structure:

BCD: Word begins at Index Count 1. BCD elements occur between Position Identifier Elements in four-bit code groups until the code word is complete. A Code Digit occurs between decimal digits in each group to provide separation for visual resolution.

4. Least Significant Digit:

Occurs first.

5. Element Rates Available:

- a. 1 PPM (basic element rate).
- b. 1 PPH (Frame rate).

6. Element Identification:

- a. On-Time is the leading edge of a pulse.
- b. Index Marker: 12 Sec (zero or uncoded bit).
- c. Code Digit: 36 Sec (one).
- d. Position Identifier: 3 Sec (same as one).
- e. Reference Marker: Five consecutive Position Identifiers followed by an Index Marker.

7. Resolution:

1 Minute (DCLS), 10 mS (modulated 100 Hz carrier); 1 mS (modulated 1 kHz carrier)

8. Carrier Frequency:

100 Hz or 1 kHz (when modulated).

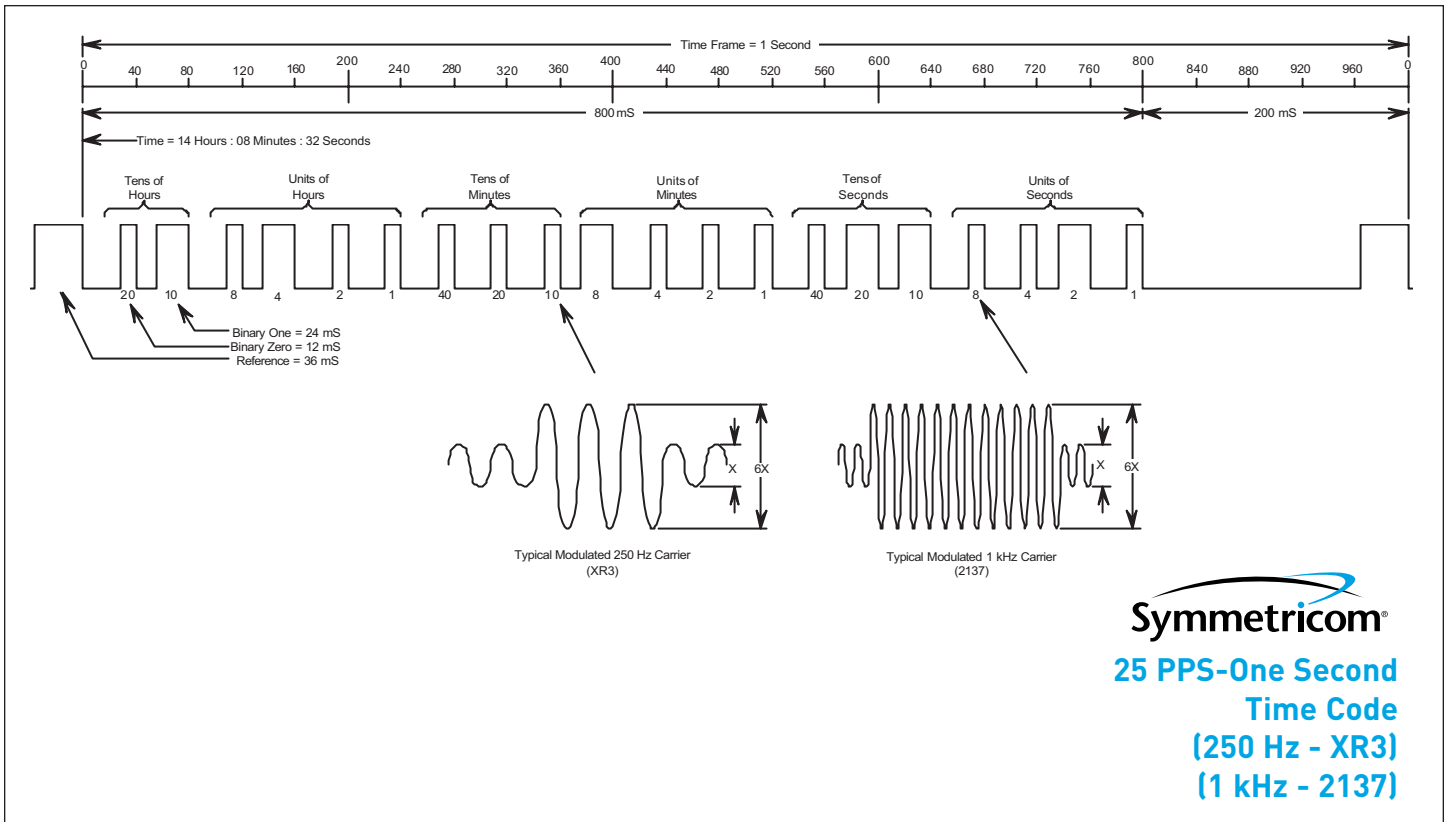

1. Time Frame:

1 second.

2. Code Weighting Options:

BCD

- a. BCD time of day code word - 20 bits. Hours, minutes and seconds, recycle daily.

3. Code Word Structure:

BCD: Word begins at Index Count 1. BCD elements occur between Position Identifier Elements consecutively (6 for hours, 7 for minutes, 7 for seconds) until the code word is complete.

4. Most Significant Digit:

Occurs first.

5. Element Rates Available:

- a. 25 PPS (basic element rate)
- b. 1 PPS (Frame rate)

6. Element Identification:

- a. On-Time is the trailing edge of a pulse.
- b. Index Marker: 12 mS (zero).
- c. Code Digit: 24 Sec (one).
- d. Reference Marker: 36 mS (once per frame).

7. Resolution:

- 1 Second (frame rate).
- a. 4 mS - modulated XR3 code.
- b. 1 mS - modulated 2137 code.

8. Carrier Frequency:

- a. 250 Hz for XR3 code.
- b. 1 kHz for 2137 code.

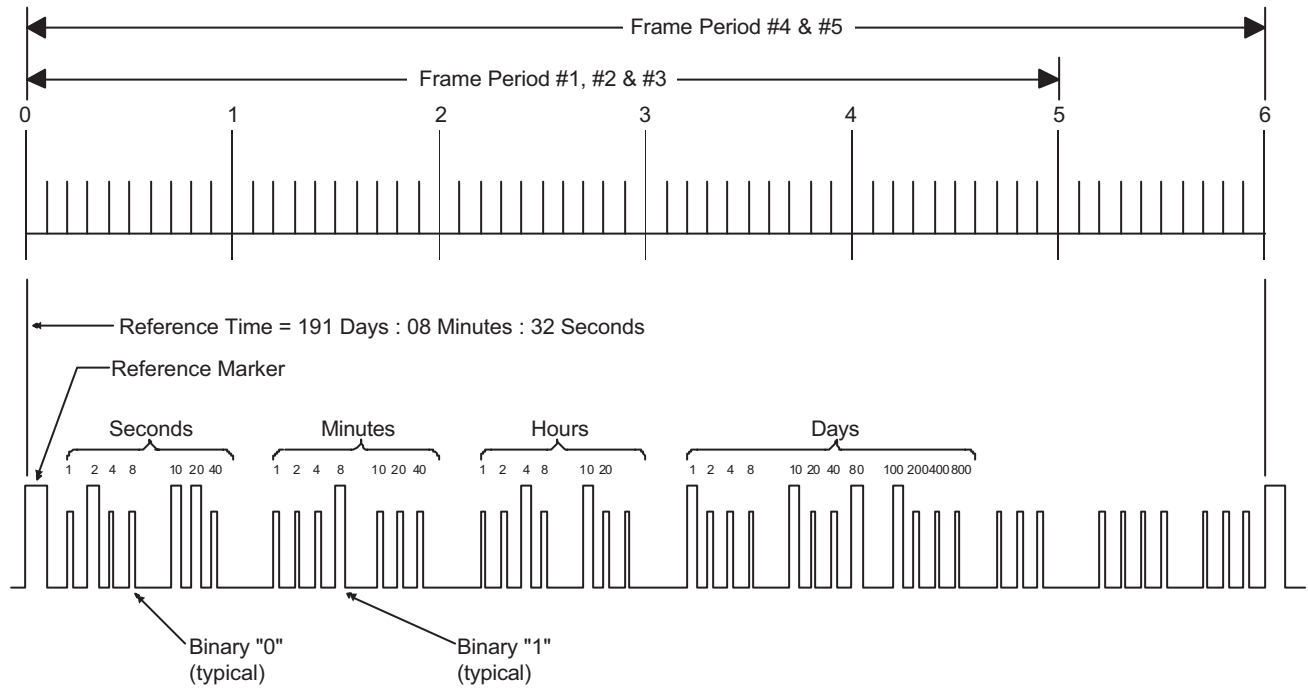

Code	Pulse Rate	Frame Period	Binary Zero	Binary One	Frame Ref. Pulse
1	50 PPS	1 Sec	4 mS	10 mS	20 mS
2	10 PPS	5 Sec	20 mS	50 mS	100 mS
3	5 PPS	10 Sec	40 mS	100 mS	200 mS
4	1 PPS	60 Sec	200 mS	500 mS	1 Sec
5	1 P/10s	10 Min	2 Sec	5 Sec	10 Sec



**Bi-Level — 5-Rate
Slow Code**

This special bi-level slow code is designed to provide a convenient and efficient time reference for strip chart and oscillograph records. Five different and unique codes are provided to enable selection of the desired resolution that is consistent with the chart paper speed.

The code is a width-modulated, BCD format. Amplitude modulation is also included to aid in the visual separation of the coded information.

Each code group is separated by a space as a further aid to fast visual recognition of the coded time infor-

mation without loss of resolution or inclusion of extraneous pulses. Coded information represents time of year in seconds, minutes, hours and days.

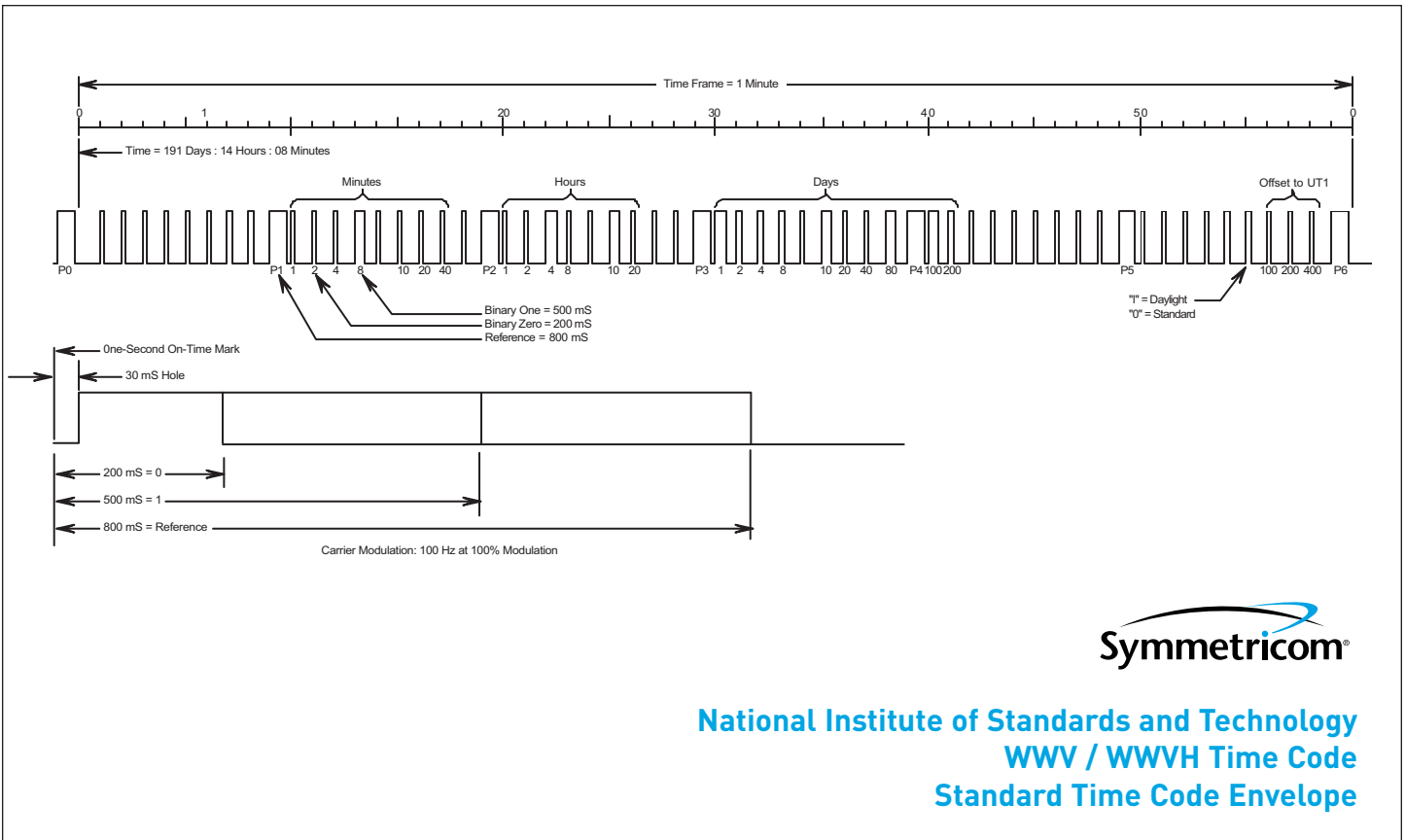

National Institute of Standards and Technology
 WWV / WWVH Time Code
 Standard Time Code Envelope

1. Time Frame:

1 minute.

2. Code Weighting Options:

BCD

- a. BCD time of day code word - 30 bits. Minutes, hours, days, Daylight Savings Time and UT Correction.

3. Code Word Structure:

BCD: Word begins at Index Count 10 + 30 mS. BCD elements occur between Position Identifier Elements (7 for minutes, 6 for hours, 10 for days, 1 for DST and 7 for UT correction) until the code word is complete. Position Identifier occurs between decimal digits in each group to provide separation for visual resolution.

4. Least Significant Digit:

Occurs first.

5. Element Rates Available:

- a. 1 PPS (basic element rate)
- b. 1 per 20 seconds (Position Identifier).
- c. 1 PPM (Frame rate).

6. Element Identification:

- a. On-Time reference for each element is 30 mS before the element.
- b. Index Marker: 170 mS (zero or uncoded element).
- c. Code Digit: 470 mS (one)
- d. Position Identifier: 770 mS.
- d. Reference Marker: 770 mS (once per frame)

7. Resolution:

1 Second unmodulated; 0.01 second modulated 100 Hz (theoretical).

8. Carrier Frequency:

100 Hz - 100% modulation.

9. Time Scale:

UTC with coded correction to UT1.

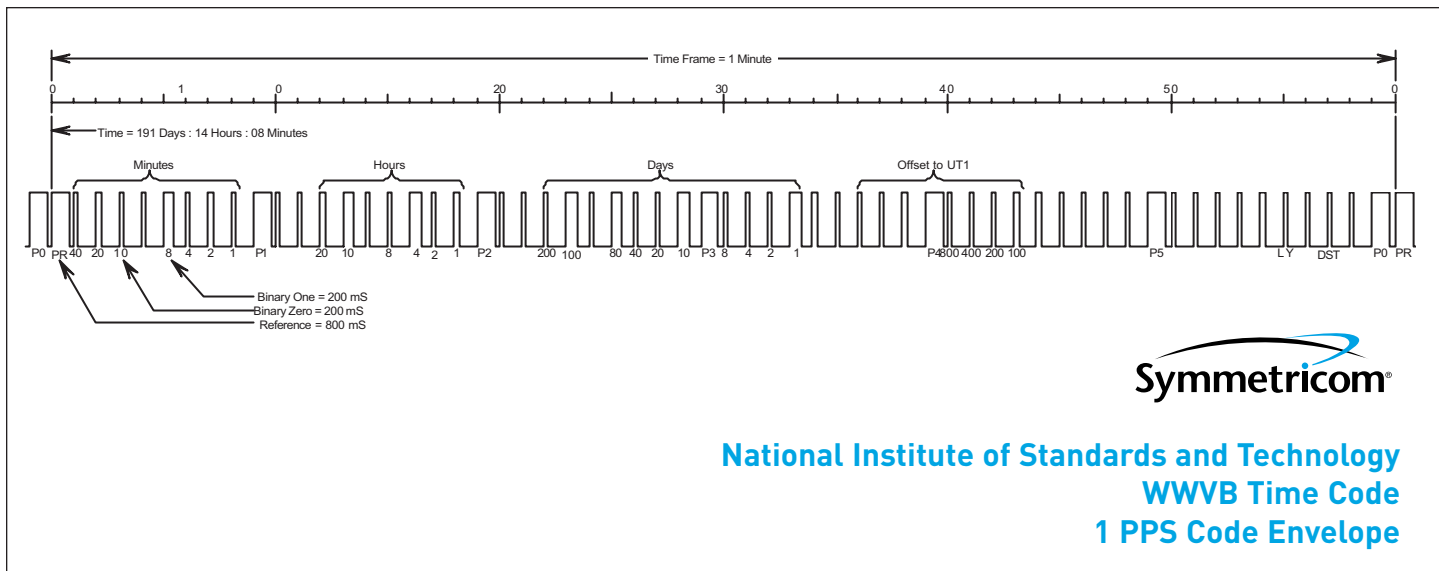

1. Time Frame:

1 minute.

2. Code Weighting Options:

BCD

- a. BCD time of day code word - 35 bits. Minutes, hours, days, UT Correction, Daylight Saving Time and leap year.

3. Code Word Structure:

BCD: Word begins at Index Count 10 + 30 mS. BCD elements occur between Position Identifier Elements (7 for minutes, 6 for hours, 10 for days, 7 for UT correction, 1 for DST and 1 for leap year) until the code word is complete. Position Identifier occurs between decimal digits in each group to provide separation for visual resolution.

4. Least Significant Digit:

Occurs first.

5. Element Rates Available:

- a. 1 PPS (basic element rate)
- b. 1 per 10 seconds (Position Identifier).
- c. 1 PPM (Frame rate).

6. Element Identification:

- a. On-Time reference for each element is the leading edge.
- b. Index Marker: 200 mS (zero or uncoded element).
- c. Code Digit: 500 mS (one).
- d. Position Identifier: 800 mS.
- d. Reference Marker: 800 mS (once per frame)

7. Resolution:

1 Second unmodulated; 0.01 second modulated 100 Hz (theoretical).

8. Carrier:

60 Hz - 1:10 modulation ratio.

9. Time Scale:

UTC with coded correction to UT1.

IEEE:1344 COMPLIANCE

The Power System Relaying Committee of the IEEE Power Engineering Society has published a document (IEEE Std 1344-1995) that discusses unique synchronizing issues that are encountered in the Power Utilities. As a part of that document (Annex F), a specific

utilization of the 'Control Bit' segment of IRIG B time code is defined. Symmetricom has determined that this definition has merit for many traditional users of time code. Accordingly, new timing products that are designed and manufactured will be 'IEEE 1344

Compliant,' which means that the 27 control bits in a standard IRIG B serial time code format are used to provide additional information as set forth by the IEEE standard. The following table defines each of the bits in the Control Function field of the IRIG B code format.

IEE 1344 Conrol Bit Assignments

P50	1	Year, BCD 1	Last 2 digits of year in BCD
P51	2	Year, BCD 2	
P52	3	Year, BCD 4	
P53	4	Year, BCD 8	
P54	5	Not Used	Unassigned
P55	6	Year, BCD 10	Last 2 digits of year in BCD
P56	7	Year, BCD 20	
P57	8	Year, BCD 40	
P58	9	Year, BCD 80	
P59	—	P6	Position Identifier #6
P60	10	Leap Second Pending (LSP)	Becomes 1 up to 59 sec BEFORE leap second insertion
P61	11	Leap Second (LS)	0=Add leap second; 1=Subtract leap second
P62	12	Daylight Savings Pending (DSP)	Becomes 1 up to 59 BEFORE DST change
P63	13	Daylight Savings Time (DST)	Becomes 1 during DST
P64	14	Time Zone Offset - Sign Bit	Offset between UTC and the time in the IRIG B time code frame (the offset will change during Daylight Savings Time)
P65	15	Time Zone Offset - Binary 1 hr	
P66	16	Time Zone Offset - 2 Hr	
P67	17	Time Zone Offset - Binary 4 Hr	
P68	18	Time Zone Offset - Binary 8 Hr	
P69	—	P7	Position Identifier #7
P70	19	Time Zone Offset - 0.5 Hr	0=None; 1=Additional 0.5 Hr time offset
P71	20	Time Quality	4-bit code representing approximate clock time error 0100=Clock locked, accuracy \leftarrow 1 microsecond 1111=Clock failed, data unusable
P72	21	Time Quality	
P73	22	Time Quality	
P74	23	Time Quality	
P75	24	Parity	Odd parity for all data bits from the frame start to CF Bit 23
P76	25	Not Used	Unassigned
P77	26	Not Used	Unassigned
P78	27	Not Used	Unassigned
P79	—	P8	Position Identifier #8



SYMMETRICOM, INC.
2300 Orchard Parkway
San Jose, California
95131-1017
tel: 408.433.0910
fax: 408.428.7896
info@symmetricom.com
www.symmetricom.com

©2004 Symmetricom. Symmetricom and the Symmetricom logo are registered trademarks of Symmetricom, Inc. All specifications subject to change without notice.