

TECHNICAL MANUAL

MODEL 8820A

GPS STATION CLOCK

November 1994

TRAK SYSTEMS MODEL 8820A GPS STATION CLOCK

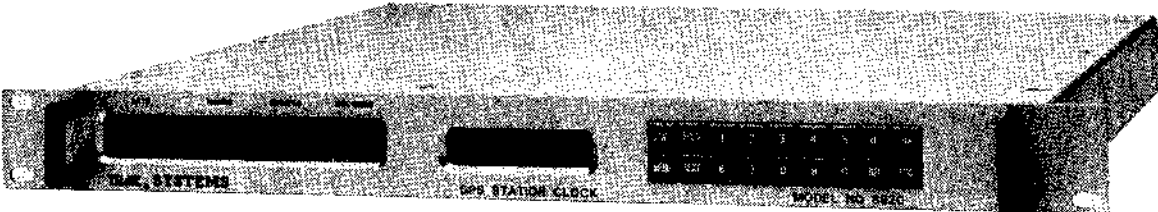

TRAK Systems Model 8820A GPS Station Clock

TRAK Systems Model 8820A GPS Station Clock

CUSTOMER OPTION SHEET

The Model 8820A GPS Station Clock covered by this technical manual has the following features and options:

FEATURES

Internal Oscillator:	Option B-4: 10 MHz oven-stabilized, disciplined crystal oscillator.
Rate outputs:	1 PPS, selected low rate and selected high rate
Time code outputs:	Selected IRIG B, 2137, or NASA 36-Bit
Computer interface (s):	RS-232A - Transmit/Receive RS-232B - Transmit only
Chassis slides:	Not provided

STATIC AWARENESS



The 8820A GPS Station Clock contains CMOS IC's that can be damaged by electrostatic discharge during handling. The following practices minimize the likelihood of CMOS IC damage:

1. Use a static-free work station.
2. Avoid plastic, VINYL, and STYROFOAM in work area.
3. Discharge personal static before handling. *Use a grounded antistatic wrist strap.*
4. Minimize handling. Do not remove and replace IC's by hand.
5. Use *grounded* IC removal and insertion tools.
6. If required, handle the IC's only by the body - **NOT** by the leads. *Use a grounded anti-static wrist strap.*
7. Do not slide the IC over any surface.

(This page intentionally blank.)

TABLE OF CONTENTS

Paragraph		Page
PREFACE		
PF1	Initial Startup (Quick Start Procedures)	PF-1
CHAPTER 1 INTRODUCTION		
1-1	General	1-1
1-2	Level of Coverage	1-1
1-3	Functional Description	1-1
1-4	Physical Description	1-2
1-5	Power Requirement	1-2
1-6	Equipment Supplied	1-2
1-7	Output Characteristics	1-2
1-8	External Signal Inputs	1-5
1-9	Environmental Characteristics	1-6
CHAPTER 2 INSTALLATION		
2-1	Unpacking Procedure	2-1
2-2	Normal Mounting Procedure	2-1
2-3	Rear Panel Connectors and Fuse	2-1
2-4	Antenna Installation	2-4
2-5	Internal Adjustments	2-4
2-6	Input Voltage Select	2-5
CHAPTER 3 OPERATION		
3-1	Operating Controls and Indicators	3-1
3-2	Setup Procedure	3-3
3-3	Remote Operation	3-15
3-4	Remote Commands	3-16
3-5	Factory Settings	3-33
CHAPTER 4 PRINCIPLES OF OPERATION		
4-1	General	4-1
4-2	Block Diagram Discussion	4-1

TABLE OF CONTENTS
(cont'd)

Paragraph		Page
CHAPTER 5		
ROUTINE MAINTENANCE		
5-1	General	5-1
5-2	Cleaning Solvents	5-1
5-3	Adjustments	5-1
5-4	Battery Replacement	5-5
CHAPTER 6		
REPLACEABLE PARTS LIST		
6-1	General	6-1
APPENDICES		
Appendix A	Glossary and Abbreviations	A-1
Appendix B	Options	B-1
Appendix C	Extended Computer Interfaces	C-1
Appendix D	GPS Overview and Position Modes	D-1
Appendix E	GPS Antenna Installation and Options	E-1
Appendix F	Time Code Formats	F-1
Appendix G	Foldout Drawings	G-1

LIST OF ILLUSTRATIONS

Figure		Page
Frontice Piece	Model 8820A GPS Station Clock	-
2-1	Model 8820A Rear Panel	2-1
3-1	Model 8820A Front Panel	3-1
3-2	Model 8820A Front-Panel Keypad	3-2
3-3	Power-Up Initiation Screen	3-3
3-4A	Primary (1) Status Screen - Acquisition Phase	3-4
3-4B	Primary (1) Status Screen - Tracking Phase	3-4
3-5	Status Screen 2	3-4
3-6A	Status Screen 3 - UTC Selected	3-5
3-6B	Status Screen 3 - LCL and Hours Offset Selected	3-5
3-6C	Status Screen 3 - LCL, Hours, and Minutes Offset Selected	3-5
3-6D	Status Screen 3 - GPS and Seconds Offset Selected	3-5
3-7	Status Screen 4 - LAT/LONG	3-6
3-8	Status Screen 5 - Height	3-6
3-9	Status Screen 6 - Leap Second	3-6
3-10	Status Screen 7 - Oscillator Cal	3-6
3-11	Status Screen 8 - Tracking Status	3-7
3-12	Status Screen 9 - EXT 1 PPS Measure	3-7
3-13	Setup Screen 01 - Position MODE SEL	3-8
3-14	Setup Screen 02 - LAT/LONG SET	3-8

**LIST OF ILLUSTRATIONS
(cont'd)**

Figure		Page
3-15	Setup Screen 03 - HEIGHT SET	3-9
3-16	Setup Screen 04 - TIME CODE SEL	3-9
3-17	Setup Screen 05 - TIME/DATE SET	3-9
3-18A	Setup Screen 06 - TIME /MODE SEL - LCL, Hours and Minutes Offset Select	3-9
3-18B	Setup Screen 06 - TIME/ MODE SEL - GPS, Seconds Offset Select	3-10
3-18C	Setup Screen 06 - TIME/MODE SEL - UTC Select	3-10
3-19	Setup Screen 07 - DAYLITE/STD Select	3-10
3-20	Setup Screen 08 - SET D/S DATES	3-10
3-21	Setup Screen 09 - High RATE SEL	3-11
3-22	Setup Screen 10 - LOW RATE SEL	3-11
3-23	Setup Screen 11 - RS-232 FORMAT	3-11
3-24	Setup Screen 12 - RS-232 SETUP	3-11
3-25	Setup Screen 13 - PRINTER FORMAT	3-12
3-26	Setup Screen 14 - PRINTER SETUP	3-12
3-27	Setup Screen 15 - SET IEEE ADDRESS	3-12
3-28	Setup Screen 16 - DLY COMP SET	3-12
3-29	Setup Screen 17 - INT/EXT 1 PPS SEL	3-13
3-30	Setup Screen 18 - REF FREQ SELECT	3-13
3-31	Setup Screen 19 - INI GPS START	3-14
3-32	Setup Screen 20 - Set Time-out	3-14
3-33	GPS Station Clock Printed Status Report	3-32
4-1	Model 8820A Block Diagram	4-1
5-1	Main Logic Assembly Adjustment Locations	5-1
5-2	Setup Screen 98 - OSC CAL MODE	5-3
6-1	Model 8820A Major Assembly Locations	6-2

LIST OF TABLES

Table		Page
1-1	Output Characteristics	1-3
1-2	External Reference Signal Characteristics	1-5
2-1	Rear Panel Connectors, Fuse, and Switch	2-2
2-2	RS-232 Connector Wiring (J11 and J12)	2-3
2-3	IEEE-488 Bus Connections (J6)	2-3
3-1	Antenna Cable Delay Specifications	3-13
3-2	Time Mark Accuracy	3-17
3-3	Logged Data Output Message Format	3-30
3-4	Model 8820A Factory Settings	3-32
6-1	Model 8820A Replaceable Parts List	6-1
6-2	Manufacturer's Code Number Identification	6-2

(This page intentionally blank)

PREFACE

INITIAL STARTUP

I - INTRODUCTION

The following paragraphs provide the instructions for installing, initializing, and operating TRAK Systems Model 8820A GPS Station Clock for the first time. Procedures are given for normal startup and for start after the unit has been moved more than 600 km or has been out of use six months or longer. Three primary operating modes are described.

The instructions in this preface are not intended to supplant the information in the body of this manual. It is suggested that both the GPS Overview and Position Mode Descriptions presented in Appendix D of this manual and the Setup Procedures provided in Paragraph 3.2 be read before attempting to optimize the operation of your instrument.

II - INSTALLATION

The installation of the Model 8820A requires that the antenna be mounted in the appropriate location and that the required cables (power, input, and output) be connected to the instrument. See Appendix E for comprehensive antenna installation coverage.

a. Standard Antenna Installation

1. Refer to Appendix E for comprehensive antenna installation coverage.
2. Connect cables, optional amplifiers, etc. to your antenna as described in Chapter 2.

b. Instrument Installation

1. If chassis slides are included with your instrument, mount the slides to the Model 8820A chassis and to the rack at the desired mounting position.
2. Slide chassis into rack. Do not install front-panel mounting screws until it has been determined whether any internal adjustments are required.

c. Instrument Signal and Power Cable Connections:

1. Referring to Figure 2-1 and Table 2-1, Rear Panel Connectors, Fuse, and Switch connect the antenna and I/O cables to the appropriate connectors on the Model 8820A rear panel.
2. Before connecting power to the Model 8820A, refer to the Customer Option Sheet (page i of this manual) for any special power configuration. The standard unit accepts a range of voltages from 85-to-265 Vac (or 100-to-370 Vdc).
3. Use the cable supplied to connect the rear-panel ac input to an 85-to-265 Vac (or 100-to-370 Vdc) source.

INITIAL SETUP

III - NORMAL INITIALIZATION

With the Model 8820A's antenna properly installed and with power applied, a unit that has been operated during the past six months and has not been moved more than 600 km should power up, initialize, acquire, and track satellites within two minutes. If the unit does not track satellites within this time, wait at least 10 minutes before changing any operating parameters.

If the unit has been moved more than 600 km but has been operated within the past six months, it may require 45 minutes or more to automatically sequence and acquire satellites when in the DYNNAV tracking mode. There are methods to shorten this sequence (see Paragraph IV) but, in most situations, it's hardly worth the effort. **Also see note under step B. below.**

If the unit has not been operated for six months or more, it has lost all usable memory of satellite locations. It may take up to two hours to automatically sequence and complete satellite acquisition. This time can be decreased significantly by using the Cold Start Procedure discussed in PARAGRAPH IV below.

As noted above, when a unit is started without having been moved more than 600 km or left out of operation for six months, satellites will be acquired within approximately two minutes and both position and precise time data will be available. For initial time sync in the FIXED tracking mode, one satellite must be visible; for navigation at a fixed location, three satellites must be visible; and for navigation when the unit is moving in azimuth, elevation, and height, four satellites must be visible. Assuming that the antenna has 360° visibility above 15°, there will be greater than four satellites available at any location worldwide.

Once a unit has acquired satellites, allow an additional five minutes for the oscillator to pull in to specified accuracy. The routine starting procedure is described below:

- a. Apply power and observe that the Power-up Initialization Screen shown in Figure 3-3 is displayed.
- b. Familiarize yourself with the operation of the keypad on the front panel. If necessary, refer to Paragraph 3.1.2 for detailed keypad operation procedures.

NOTE

If the unit has been moved more than 600 km and the Position Mode has been changed from its factory setting of DYNNAV, use Setup Screen Number 01 to switch to the DYNNAV mode. The available modes are described at the end of Appendix D. Make no other changes at this time.

- c. In less than 60 seconds, the Acquisition Phase Primary Status Screen shown in Figure 3-4A is automatically displayed. If you have inadvertently pressed any keys on the front panel keypad before the Primary Status Screen appears, press the STAT key and then the ESC key to return to the Primary Status Screen.
- d. Within approximately two minutes, the Tracking Phase Primary Status Screen shown in Figure 3-4B should appear. If, after the stated time, the Primary Status Screen does not indicate satellite tracking, proceed to paragraph IV, following. If operation is normal, proceed to paragraph V.

IV - SPECIAL START PROCEDURES

Given enough time, the unit will automatically follow a set sequence that will eventually acquire satellites, discipline its oscillator, and output accurate data. In fact, 99% of the time there is no need to resort to bypassing this automatic sequence. The procedures given here cover the special cases where it is desired to speed up acquisition. First, a definition of the starting modes:

Starting Modes:

Warm Start - This is the unit's default mode when it is first powered up with an antenna properly positioned. After power-up, the unit goes through a validation sequence and normally completes Warm Start within two minutes. If the unit has not acquired at least two satellites after 30 minutes, it assumes that position, date, and time are incorrect and it moves to the 'Cold Start' mode.

Cold Start - This is a "last resort" mode to be used if the unit has insufficient retained satellite data or if internal communication between the Model 8820A and its built-in receiver have broken down. Select this mode if the unit cannot complete a successful Warm Start after 30 minutes. Also use this method for the first start after the battery on the main logic board is replaced with power removed. A Cold Start command completely clears all receiver memory, causing it to search for all 36 possible satellites at all ranges.

The instrument is shipped from the factory with the setup parameters presented in Table 3-4. These operating parameters allow the Model 8820A to acquire and track satellites under most conditions. Whenever these parameters are changed, the newly-selected values are set into nonvolatile memory and become new default parameters at power-on. When the unit is moved more than 600 km from its place of last operation, and there is no operator intervention, it may take up to forty-five (45) minutes for it to complete the navigation solutions necessary to define the new antenna position. This time can be reduced to less than five minutes by entering an approximate new local position and using a special start procedure. To facilitate satellite acquisition and tracking after an equipment move, proceed as follows:

- a. Using Setup Screen 1, select the 'DYNAV' Mode, if it is not already selected.
- b. At this point, chose one of the following procedures that best meets your situation:
 1. As noted in PARAGRAPH III above, you can allow the unit to remain in its default automatic start sequence. This is the preferred choice; however, start time could be 45 minutes or greater. This time can be shortened by using one of the optional start methods below.
 2. If you moved to a new location and know your local position within one degree of longitude and latitude, enter the new position using Setup Screen Number 2 (height need not to be entered) and then perform a 'Warm Start'.
 3. If the unit has been moved more than 600 km, you don't know your local coordinates, and you want to reduce start time by 30 minutes, jump directly to 'Cold Start'.
 4. If the unit has been out of service for more than six months, you can reduce start time by as much as one hour by jumping directly to 'Cold Start' Also, use this method for the first start after the battery on the Main Logic Assembly has been replaced with power removed.

After the unit is tracking satellites, you may chose to use Setup Screen 01 to change the position mode of operation to either 'AUTO' tracking or 'FIXED' position. These modes can yield greater accuracy, as described in Appendix D.

INITIAL SETUP

V - INITIAL SETUP

- a. If the antenna lead-in length has been changed, use Table 3-1, Antenna Cable Delay Specifications, to calculate the signal delay (in nanoseconds) between the antenna and the Model 8820A's internal GPS Receiver input. Enter this value on Setup Screen 16. If the factory-supplied cable is being used, no change is necessary.
- b. Press the keypad STAT key then the ESC key to return to Primary Status Screen. Determine whether the Model 8820A is tracking satellites and is locked to GPS time. If, after a period of one hour, the unit is not tracking - proceed as follows:
 1. Review your installation to confirm that the antenna is correctly positioned and that the instrument antenna and power cables are installed and connected correctly.
 2. If you have not entered a correct approximate antenna position, do NOT attempt to guess at a position. The Model 8820A's receiver will automatically search for four satellites and calculate the antenna's position. If you have not jumped to a special Start Mode (as described in Paragraph IV above), this could take 45 minutes or more.
- c. Referring to Paragraph 3-2.2, Status Screens, use the STAT or NEXT key to step through each Status Screen. Read the descriptive material in Chapter 3 following each status screen to familiarize yourself with the information displayed. An understanding of this information is required before using the Setup Screens to change the Model 8820A operating parameters.
- d. Referring to Paragraph 3-5, Factory Settings, use MENU and number keys to sequentially step through each Setup Screen. Compare the factory setting(s) with your desired operating parameters. Note the number of each Setup Screen where changes are required in the column provided in Table 3-4.

NOTE

When the MENU key or NEXT key is sequentially pressed, the Setup Screen numbers and associated Menu Screen titles are sequentially displayed. These are *inactive* screens.

These screens allow you to search for a Setup Screen number without referring to the manual. The MENU key and the *number keys* must be pressed to display the active Setup Screen.

- e. Referring to Paragraph 3-2.3, Setup Menus and Screens, page through the Setup Menus until the desired Setup Screen number is displayed, then press MENU and the Setup Screen number keys to select your desired Setup Screen. When the Setup Screen number is known, the Setup Menus can be bypassed by pressing MENU key and the number keys for the Setup Screen desired. Once in a Setup Screen, the NEXT and PREV keys may be used for scrolling through the Setup Screens.
- f. Referring to Paragraph 3-2.3, Setup Menus and Screens, enter and store new operational data as required and enter changed parameters in the column provided in Table 3-4.

CHAPTER 1

INTRODUCTION

1-1 GENERAL

This manual contains the description, operating instructions, theory of operation, and maintenance data for TRAK Systems Model 8820A GPS Station Clock. It is intended to provide electronics personnel with the information necessary to operate and maintain the instrument.

1-2 LEVEL OF COVERAGE

With the exception of firmware and battery replacement, this manual provides coverage to the replaceable-assembly level only. No schematic or logic diagrams of replaceable assemblies are provided unless specifically negotiated with the purchase of your instrument. It is not intended that either field or secondary-level maintenance be performed on the replaceable assemblies. Except where specific adjustment procedures are provided, no attempt should be made to repair the replaceable PC card assemblies, the GPS receiver, the oscillator, or the power supplies. These assemblies must be returned to the factory for repair.

1-3 FUNCTIONAL DESCRIPTION

TRAK Systems Model 8820A GPS Station Clock, shown in the frontispiece, combines a GPS receiver with a precise time signal generator in a single 1.72-inch high, rack-mountable instrument that simultaneously tracks up to six GPS satellites (SVs), displays antenna position, and either UTC or Local Time. While tracking, the Model 8820A outputs time and frequency signals synchronized to within 100 nanoseconds of GPS/UTC time received from the satellite(s). During times when no satellites are being tracked and no external reference frequency is being used, the instrument time-output drift is less than 10 microseconds per hour with the standard crystal oscillator. The specifications of the Model 8820A's internal GPS receiver are as follows:

Receiver Description:	L1 C/A code pseudo-ranging
Channels:	Six independent, continuous tracking channels
Frequency:	1575.42 MHz
Corrected Time Outputs:	One hundred nanoseconds or less to UTC or GPS (one sigma) when Selective Availability (SA) is not implemented. Accuracy when SA is implemented is 200-300 nanoseconds rms.
Acquisition Time:	Typically, about two minutes.
Position Accuracy:	The position of the Model 8820A's receiver antenna is determined by measuring the pseudo-range to four satellites and computing the position of these satellites using ephemeris data. Antenna latitude, longitude, and height are displayed with accuracy of ± 100 meters (± 30 meters without SA).

Table 1-1. Output Characteristics (continued)

OUTPUT	CHARACTERISTICS	
CODE OUTPUT	Type: Amplitude: Drive: Modulation Ratio: Coherence: Connection:	Keypad or remotely-selected IRIG B122, NASA 36-Bit, or 2137 serial modulated time code. Adjustable 1 to 4.0 volts peak-to-peak ** Factory adjusted to 3.0 volts peak-to-peak. 50 ohms Adjustable 2:1 to 6:1 ** Factory adjusted to 3:3:1. Coherence to 1 PPS 'On Time' is less than 2 microseconds. Rear-Panel BNC connector J17
RS-232A	Function: Signal type: Accuracy: Transfer Time: Baud Rate Parity: DSR: Connection:	Port can be connected to a remote computer, modem, or dumb terminal. This interface provides command echoing and responds to asynchronous ASCII command data that provide remote setup of unit and request status and time outputs. RS-232 The start bit of the first serial time output character occurs within one millisecond of the leading edge of the 1 PPS OUTPUT at 8820A rear panel connector J14. Less than 100 milliseconds at 2400 baud 300, 600, 1200, 2400, 4800, 9600, or 19.2K* odd, none, or even * (Data Set Ready) enabled or disabled * Rear-panel DE-9 connector J11
RS-232B	Function: Signal type: Baud Rate: Parity: DSR: Connection:	Provides status data to printer or terminals. RS-232 300, 600, 1200, 2400, 4800, 9600, or 19.2K* odd, none, or even * (Data Set Ready) enabled or disabled * Rear-panel DE-9 connector J12
IEEE-488 option	I/O Data	See Paragraph 3-3.2 for a description of input commands and output data.

NOTES: * Keypad selectable
 ** See Chapters 2 and 5 for internal adjustment descriptions and procedures.

1-8 EXTERNAL SIGNAL INPUTS

The Model 8820A can accept 1 PPS and high frequency (1, 5, or 10 MHz) external inputs. These inputs may be used as described below. Signal characteristics are given in Table 1-2.

1-8.1 External 1 PPS

Use this port to measure the time interval between an external 1 PPS source and internal 1 PPS (UTC). See Status Screen 8 for value and Setup Screen 17 to enable measurement.

1-8.2 External Frequency Input

An external frequency may be used as a clocking source for frequency and time accumulation; however, using this Input disconnects the unit from the GPS-disciplined frequency and its inherent long term accuracy. If the external frequency is derived from a cesium beam or better standard, the outputs from the Model 8820A are somewhat more stable, but there is no long term accuracy advantage over using GPS.

Table 1-2. External Reference Signal Characteristics

INPUT	CHARACTERISTICS	
1 PPS Input signal measurement source *	Range:	Input 1 PPS must be within ± 5 milliseconds of UTC
	Resolution:	The time interval between the external 1 PPS and the GPS or UTC reference is measured with 20 nanosecond resolution.
	Amplitude:	3.5 to 10 volts peak
	Impedance:	50 ohms
	Connection:	Rear-panel BNC connector J18
1,5, or, 10 MHz REF Input*	Source:	Normally from cesium standard
	Amplitude:	1V rms sinewave or TTL
	Impedance:	50 ohms
	Connection:	Rear-panel BNC connector J19

NOTE: * Keypad selectable

1-9 ENVIRONMENTAL CHARACTERISTICS

The instrument meets all specifications when operated over the temperature range of -10 C° to +50°C and may be stored at locations having the same temperature range. Maximum operating relative humidity is 95% and when factory packaged or in its optional custom carrying case, the instrument withstands normal shock and vibration found in all forms of common-carrier shipment.

(This page intentionally blank)

CHAPTER 2 INSTALLATION

2-1 UNPACKING PROCEDURE

The Model 8820A, when not installed in its special carrying case or in a system rack, is packed for shipment in an antistatic bag nested in a molded Styrofoam cushion located in the bottom of a shipping carton. Accessories, such as the antenna, antenna cable, chassis slides, and power cord are also nested in the molded bottom cushion. A separate molded Styrofoam top cushion is placed between the 8820A and the carton top. Unpack the 8820A as follows:

- a. Examine shipping container for any signs of damage and rough handling. Record any damage observed.
- b. Remove and retain shipping list from outside of carton.
- c. Open shipping carton top and lift out molded Styrofoam top cushion.
- d. Examine contents for any sign of damage and record any damage noted.
- e. Remove 8820A and its accessories from the carton.
- f. Unpack the 8820A from its antistatic bag and accessories from their shipping bags.
- g. Check to ensure that all items listed on the packing list have been removed from the shipping carton.
- h. Remove and retain antistatic covers from 8820A's connectors.
- i. Retain shipping carton and all packing material for future use.

2-2 NORMAL MOUNTING PROCEDURE

The Model 8820A is designed for mounting in a standard 19-inch rack. Chassis slides can optionally be provided for easier servicing. Unit height is 1.72 inches and unit depth is 16 inches. Allow at least four inches behind the unit for cable clearance. Free flow of circulating air should be available to assure an ambient temperature not exceeding 50° C.

2-3 REAR PANEL CONNECTORS AND FUSE

The Model 8820A standard rear panel is shown in Figure 2-1. The connectors and fuse for the standard rear panel are described in Table 2-1. If your instrument has optional outputs, refer to Appendix B, Options.

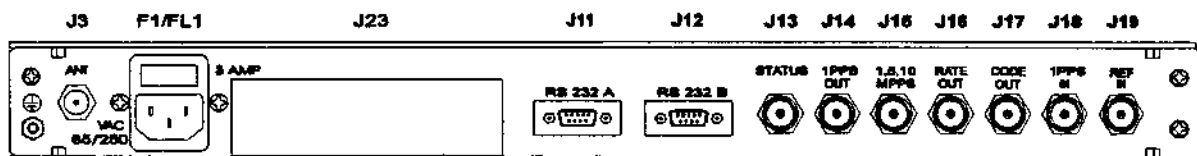

Figure 2-1. Model 8820A Rear Panel

Table 2-1. Rear Panel Connectors, Fuse, and Switch

REF DES	FUNCTION	CHASSIS CONNECTOR	MATING CONNECTOR OR CABLE
XF1	85-to-265 Vac or 100-to-370 Vdc input		Power Cable W1
F1	3 amp slo-blo fuse	Installed in FL1 Assy	
GND	Ground connector	E1	
J3	ANTENNA connector	TNC female	See Appendix E.
J11	RS-232 A connector (See Table 2-2 for connections).	DE9 female	Computer, monitor, or modem for external setup and monitoring.
J12	RS-232 B serial output to PRINTER (See Table 2-2 for connections.)	DE 9 female	Nine-pin printer cable
J13	STATUS output	BNC female	BNC male
J14	Corrected 1 PPS OUTput signal	BNC female	BNC male
J15	Selectable 1,5, or 10 MPPS high rate output signal	BNC female	BNC male
J16	Selectable decade 1 PPM, 1 PPH, 6 PPH, 12 PPH or 1 PPS thru 1 MPPS decade low-RATE OUTput	BNC female	BNC male
J17	Selectable IRIG B, 2137, or NASA 36-Bit serial time CODE OUTput signal	BNC female	BNC male
J18	1 PPS INput	BNC female	BNC male
J19	Selectable 1, 5, or 10 MHz external REF signal INput	BNC female	BNC male
J23	Optional (See Appendix B)	BNC female	BNC male

2-3.1 RS-232 A and B Connector Pin Connections

The pin connections for RS-232 A connector J11 and RS-232 B connector J12 are listed in Table 2-2.

Table 2-2. RS-232 Connector Wiring (J11 and J12)

PIN NUMBER	RS-232 A CONNECTOR J11 SIGNAL	RS-232 B CONNECTOR J12 SIGNAL
1	NC	NC
2	TX data (Data Out)	TX data (Data Out)
3	RX data (Data In)	RX data (Data In)
4	DTR (Data Terminal Ready)	NC
5	Ground	Ground
6	DSR (Data Set Ready)	NC
7	NC	NC
8	NC	DSR (Data Set Ready)
9	NC	NC

2-3.2 IEEE-488 I/O Connector Wiring

When ordered as an option, the IEEE-488 I/O is provided on rear panel connector J6. The wiring of J6 is listed below in Table 2-3.

Table 2-3. IEEE-488 Bus Connections (J6)

SIGNAL	PIN	SIGNAL	PIN
D101	1	IFC	9
D102	2	SRQ	10
D103	3	ATN	11
D104	4	Shield	12
D105	13	REN	17
D106	14	Ground	18
D107	15	Ground	19
D108	16	Ground	20
DOI	5	Ground	21
DAV	6	Ground	22
NRFD	7	Ground	23

Note: Standard IEEE-488 bus signal connections used.
Standard IEEE-488 interconnecting cable recommended.

Chassis connector - Amphenol P/N 2003956-1012
Mating Connector for cable - Amphenol P/N 552700-#

2-4 ANTENNA INSTALLATION

Refer to Appendix E for full details on antenna installation.

2-5 INTERNAL ADJUSTMENTS

The Model 8820A GPS Station Clock has an oscillator adjustment, a LCD Display CONTRAST ADJUSTment, and time-code-output amplitude, phase, and modulation-ratio adjustment potentiometers located on Main Logic Assembly A1. With the Model 8820A withdrawn from the rack, access to these adjustments is obtained by loosening the eight, quarter-turn fasteners holding the top cover to the instrument chassis and removing the cover.

The signal output at rear-panel time **CODE OUT**put BNC connector J17 is factory adjusted for:

Amplitude:	3.0V p/p
Modulation Ratio:	3.3:1
Phase:	Best zero crossing .

Should adjustments of the time code signal output amplitude, modulation ratio, or phase be required, refer to Chapter 5, Maintenance, for adjustment procedures.

The Model 8820A is offered with a standard B-4 Option oven-controlled crystal oscillator. Should the oscillator in your instrument require adjustment, Status Screen 7 (Figure 3-10) on the front-panel display will state that adjustment is needed. Refer to CHAPTER 5 for oscillator adjustment procedures.

2-6 INPUT VOLTAGE SELECT

The Model 8820A operates on power from 85-to-265 Vac or 100-to-370 Vdc and requires no voltage range switchover. The 3 ampere fuse supplied with the unit is correct for any voltage within this range.

CHAPTER 3 OPERATION

3-1 OPERATING CONTROLS AND INDICATORS

The front panel of the TRAK Systems Model 8820A GPS Station Clock contains a LCD display for viewing instrument status and setup data and an 18-key alphanumeric keypad for entering or modifying setup data. The Model 8820A also contains an LED display for viewing Time-of-Year (TOY) in days, hours, minutes and seconds. Individual LED receiver 'TRACKING' and internal oscillator 'LOCKED' indicators are provided within the Time-of-Year (TOY) display.

If sufficient information is provided by the user, TRAK Systems will configure the instrument and store the setup parameters in the battery backed-up memory before shipment. If not changed by the operator, these set-up parameters are stored for as long as 10 years, and the instrument will power up with no further setup required. When customer configuration information is not provided to TRAK Systems before shipment, the instrument is set up using the factory and/or default settings noted in Table 3-4. If required, the operator may customize the instrument operations using the front-panel interactive keypad and LCD Display shown in Figure 3-1.



Figure 3-1. Model 8820A Front Panel

3-1.1a Alphanumeric Display

The alphanumeric LCD display has two lines of 16 characters. This display is backlit for increased viewability in low ambient-light environments. If required, the contrast of the display may be adjusted using the CONTRAST Adjustment located inside the instrument on Main Logic Assembly A1. The Model 8820A display features a set of Status screens for monitoring instrument operation and a set of Setup Screens to enter or change instrument operating parameters. After a brief initialization period, when the instrument verifies its operation, the Model 8820A powers up with the main Status Screen displayed. Additional status screens may be displayed using the STATUS and associated NEXT and PREVIOUS keys on the keypad. Data entry of Setup parameters is accomplished by using the menu displays selected by the MENU key, selecting the desired Setup Screen from a menu display, and changing parameters in the selected Setup Screen.

3-1.1b Numeric Display

The numeric display contains nine, high-intensity LED indicators for viewing UTC or LOCAL time in days, hours, minutes and seconds and individual LED GPS Receiver TRACKING and Internal oscillator LOCKED status indicators.

3-1.2 Keypad

The front-panel 18-key keypad is shown in Figure 3-2. Following, is a description of the operation of the individual keys.

STAT	PREV	1	2	3	4	5	←	→
MENU	NEXT	6	7	8	9	0	SEL	ESC

Figure 3-2. Model 8820A Front-Panel Keypad

STAT Places the display in the Status mode and displays one of the status screens. Other status screens may be viewed using the **NEXT** and **PREV** keys or by repetitively pressing the **STAT** key.

MENU Places the unit in the Setup Mode and displays a page of setup choices. Other pages may be viewed using the **NEXT** and **PREV** keys.

The desired Setup Screen can then be selected by entering the two-digit screen number. The operator does not have to refer to the menu screen if number of the Setup Screen is known. To select a Setup Screen, press **MENU** key plus the two-digit Setup Screen number. Also, any Setup Screen may be reached from any other Setup Screen by pressing **MENU** and entering the two-digit Setup Screen number.

NEXT Scrolls to the next screen when viewing one of the Status, Menu, or Setup Screens. When in the Setup Mode, Pressing the **NEXT** key after entering data stores the revised Setup data and moves the display to the next screen. The display wraps around to the first screen after exiting the last screen.

PREV Scrolls to the previous screen when viewing one of the Status, Menu, or Setup Screens. When in the Setup mode, pressing the **PREV** key after entering data stores the revised Setup data and moves the display to the previous screen. The display wraps around to the last screen after exiting the first screen.

0 - 9 When entered after pressing **MENU**, the first two digits select a Setup Screen. Once in the selected Setup Screen, the number keys are used to enter data.

ESC Usage varies with mode as follows:
Status: Returns to first (main) Status screen
Setup: Returns Setup data on current screen to values existing when screen was brought up.

SEL Scrolls data through available choices on some Setup Screens. For example, **SELECT TIME CODE FOR OUTPUT** screen, the selection scrolls between **IRIG B**, **2137**, and **NASA 36-BIT**. The **SEL** key also allows the user to change sign on selected data to be either **+** or **-**.

←→ When in a Setup Screen, left and right arrows move cursor for data entry or corrections. The right arrow moves the cursor to the next field and the left arrow moves the cursor to the previous field.

3-2 SETUP PROCEDURES

The following paragraphs describe how to set up the Model 8820A Station Clock to meet your operational requirements. The Model 8820A powers up, initializes, and acquires satellites with minimal operator intervention. Though satellite acquisition is automatic, the Model 8820A acquires satellites faster when the instrument's stored antenna position is within 600 km of its actual position. The Setup procedures allow the operator to optimize the operation of the Model 8820A and to customize its outputs.

Table 3-4 lists the operational parameters that are factory set in the Model 8820A. Review these parameters in the associated Setup Screens and change parameters as required. Read Appendix D to familiarize yourself with the GPS System and navigational modes then read the descriptive material accompanying each Setup procedure before changing stored data. Enter any changed parameters in the space provided in Table 3-4.

3-2.1 System Initialization

When power is applied to the Model 8820A, it automatically performs system initialization and checkout before turning control over to the user. When initialization is complete, the Primary (default) status screen is displayed. Use the keypad **STAT**, **NEXT**, or **PREV** keys to move between Status screens. The Power-Up Initialization Screen is shown in Figure 3-3.

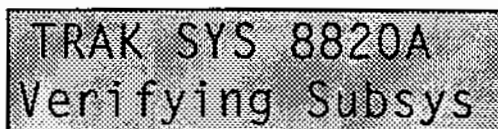
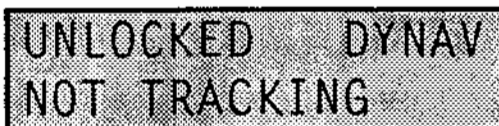

Figure 3-3. Power-UP Initiation Screen

3-2.2 Status Screens

When system initialization is complete, the following primary Status screens are successively displayed until satellite tracking begins.



A rectangular screen with a halftone background. The text is arranged in two lines. The first line contains the words "UNLOCKED" and "DYNAV" separated by a wide space. The second line contains the words "NOT TRACKING" and a wide space.

Figure 3-4A. Primary Status Screen, Acquisition Phase

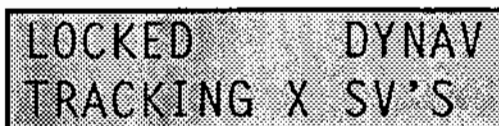

A rectangular screen with a halftone background. The text is arranged in two lines. The first line contains the words "LOCKED" and "DYNAV" separated by a wide space. The second line contains the words "TRACKING X SV'S" where 'X' is a single character and "SV'S" is followed by a wide space.

Figure 3-4B. Primary Status Screen, Tracking Phase

The first line initially displays UNLOCKED. When satellites are acquired and the internal reference - UTC is less than 250 nanoseconds, the message is replaced with LOCKED. Should the reference - UTC be greater than 500 microseconds, FREE RUNNING is displayed until the difference between reference and UTC is again less than 250 nanoseconds.

On the right side of the first line, the selected AUTO, FIXED or DYNAMIC NAV Position Mode is displayed.

The second line initially displays NOT TRACKING. When satellites are acquired, the message is replaced with TRACKING SV'S. The 'X' represents the number of satellites presently being tracked (1 to 6).

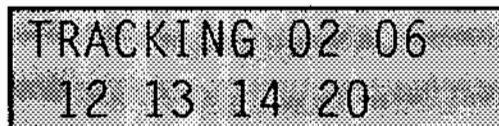

A rectangular screen with a halftone background. The text is arranged in two lines. The first line contains the words "TRACKING 02 06" where "02" and "06" are separated by a wide space. The second line contains the numbers "12 13 14 20" separated by wide spaces.

Figure 3-5. Status Screen 2 - Satellites Being Tracked

Displays satellite PRN's presently tracking. If not tracking satellites, the screen is replaced with NOT TRACKING SV's, NO INFORMATION.

NOTE

The numbers displayed above and used in the serial RS-232 outputs are PRN numbers that identify the satellites being tracked. These PRN numbers are not the space vehicle (SV) numbers that define the order in which the satellites were put into orbit.

3-2.2 Status Screens (cont'd)

14 SEP 1994
UTC

Figure 3-6A. Status Screen 3 - UTC Selected

First line displays time in Day-of-Month, Month and Year. Second line displays selected time mode, LOCAL, GPS, or UTC., Second line is as shown when UTC is selected in Setup Screen 06.

14 SEP 1994
LCL DST -05HOURS

Figure 3-6B. Status Screen 3 - LCL and Hours Offset Selected

Second line is as shown when LCL (local) time, hours offset, and no minutes have been selected in Setup Screen 06.

14 SEP 1994
LCL DST -05H 15M

Figure 3-6C. Status Screen 3 - LCL, Hours, and Minutes Offset Selected

Second line is as shown when LCL (local) time, hours offset, and minutes offset have been selected in Setup Screen 06.

14 SEP 1994
GPS OFFSET 09SEC

Figure 3-6D. Status Screen 3 - GPS and Seconds Offset Selected

Second line is as shown when GPS time has been selected in Setup Screen 06. GPS offset entered on second line of Setup Screen 06 is displayed .

3-2.2 Status Screens (cont'd)

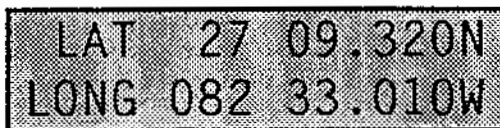

LAT 27 09.320N
LONG 082 33.010W

Figure 3-7. Status Screen 4 - LAT/LONG

Continuously displays the last navigation solution. To view last manually-entered position, see Setup Screen 02.

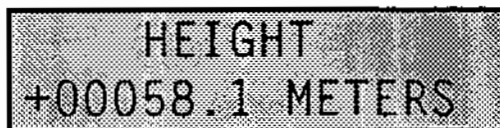

HEIGHT
+00058.1 METERS

Figure 3-8. Status Screen 5 - Height

Continuously displays the last calculated height. To view last manually-entered height, see Setup Screen 03.



NO LEAP SECOND
SCHEDULED

Figure 3-9. Status Screen 6 - Leap Second

Displays NO LEAP SECOND SCHEDULED until arm signal is received from the satellites. When armed, the display changes to:

LP SEC SCHEDULED
30 JUNE (or other date that the leap second will occur)

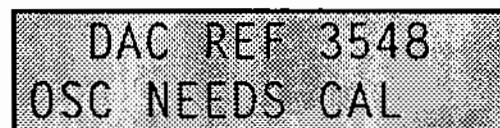

DAC REF 3548
OSC NEEDS CAL

Figure 3-10. Status Screen 7 - Oscillator Cal

When DAC REFERENCE value is less than 500 or greater than 3500, the message on the second line reads OSC NEEDS CAL. The 8820A contains a B-4 option oven-stabilized disciplined crystal oscillator. Refer to Chapter 5 for oscillator adjustment procedures.

3-2.2 Status Screens (cont'd)

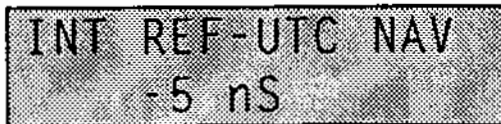

Figure 3-11. Status Screen 8 - Tracking Status

"INT REF-UTC" is displayed when UTC Time Mode is selected. If GPS Time Mode is selected, the message "INT REF-GPS" is displayed. NAV is one of several codes indicating the tracking status of the GPS receiver. The status codes are as follows:

- STS - Searching for satellites (no almanac)
- TRK - Tracking satellites but not navigating
- NAV - Navigating
- IAC - Initial Acquisition
- ALT - Constellation selection
- ACQ - Satellite reacquisition
- IDL - Idle, no satellites visible

The second line displays a measurement that indicates the phase relationship between the Internal 1 PPS reference and UTC or GPS. If a measurement is not displayed, then one of four messages will be displayed. The messages are as follows:

- WAIT FOR REF - Time information is not being output by the Internal GPS Receiver.
- WAIT FOR OSC - The Internal oscillator has not stabilized.
- FIND OSC CTR - A search for the center frequency of the internal oscillator is in process
- COUNTER ERROR - This message is displayed when internal 1 PPS is not within 5 mil
liseconds of UTC or if EXTERNAL REFERENCE FREQUENCY is selected
and not present.

NOTE

When 'COUNTER ERROR' is displayed, check Setup Screen 18 to make sure that you have not accidentally selected EXTERNAL REF FREQUENCY instead of INTERNAL. Selection of an external reference frequency when said reference frequency is not present *will disable the Model 8820A.*

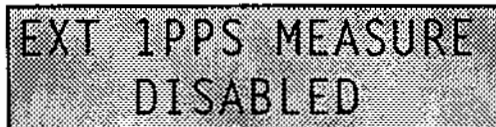

Figure 3-12. Status Screen 9 - External 1 PPS Measure

If EXTERNAL 1PPS measurement is enabled, second line displays time-interval measurement (in nano-seconds) between EXT 1 PPS Input and internal 1 PPS. If EXTERNAL 1 PPS measurement is disabled, second line displays DISABLED. When external 1 PPS is enabled, but is not present, ????????? is displayed on second line.

3-2.3 Setup Menus and Screens

The following are the Setup Screens that may be selected from the Setup Menu. At the Setup MENU enter the two digits representing the desired Setup Screen. This brings you to the Setup Screen where operational data may be entered or modified. Use the keypad $\leftarrow\rightarrow$ keys to move through the various fields in each screen.

NOTE

The Setup Screens can be entered only by pressing the MENU key and the two-digit Setup Screen number keys. When MENU key is successively pressed, Setup Screen Numbers with associated Setup Screen subjective titles are displayed. These screens are not active and are used only as menus to locate the number of the desired Setup Screen. You can also move between menu screens using the NEXT and PREV keys.

Use the numerical keys to enter data and the SEL key, where appropriate, to select between choices or to change sign (+ or -). The SEL key also changes the choices in each field and the data displayed for that field are temporarily stored. If, before leaving a screen, you decide that you did not want to change data in a particular field, return to that field, press ESC key and the original value existing in that field is restored.

Exit the Setup Screen using the NEXT, PREV, STATUS, or MENU keys and the data entered or changed in that screen are permanently stored until next entry into that screen.

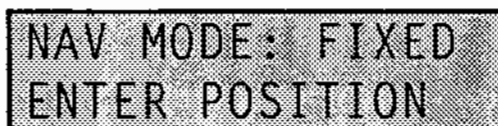

NAV MODE: FIXED
ENTER POSITION

Figure 3-13. Setup Screen 01 - Position (NAV) MODE SEL

There are three choices: 'DYNAV', 'AUTO' Tracking, and 'FIXED' Position. A warning message "ENTER POSITION" appears when 'FIXED' Position is selected. Refer to Appendix D for an explanation of the navigational position modes.

The 'FIXED' Position mode allows acquisition of precise time starting with only one satellite, but the antenna position must be manually input using Setup Screen 02 or remotely entered via the RS-232 or optional IEEE-488 port.

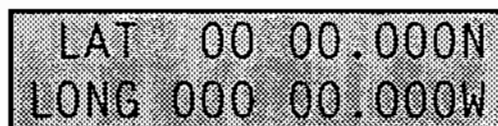

LAT 00 00.000N
LONG 000 00.000W

Figure 3-14. Setup Screen 02 - LAT/LONG SET

This setup is not required in the 'Dynamic NAVigate' or 'AUTO' Position Mode.

In the 'FIXED' Position Mode, an accurate position must be entered in order to obtain specified time accuracy. Accurate position is available from data recorded in one of the other modes or from geodetic survey. In DYnamic NAVigate or AUTO Position Mode, when the instrument has been moved more than 600 Km, the time required to acquire a new position can be minimized by entering an estimated new position.

3-2.3 Setup Menus and Screens (cont'd)



SET HEIGHT
+00000.1 METERS

Figure 3-15. Setup Screen 03 - HEIGHT SET

Sets antenna height position.



SELECT TIME CODE
IRIG B

Figure 3-16. Setup Screen 04 - TIME CODE SELECT

Selects time code output to rear-panel CODE OUTPUT BNC connector J17. SEL key scrolls through code outputs choices (IRIG B, 2137, and NASA-36 Bit). See Appendix F for descriptions of time codes.



DATESET 06/29/92
TIMESSET 12:32:21

Figure 3-17. Setup Screen 05 - TIME /DATE SET

This Setup is Non-mandatory. At startup, do not enter a UTC time that is incorrect by more than five minutes as it will cause a significant delay in the Model 8820A acquiring satellites.



TIME MODE LCL
OFFSET -05H 15M

Figure 3-18A. Setup Screen 06 - TIME MODE SEL - LCL, Hours, and Minutes Offset Select

'GPS', 'UTC' or 'LCL' (local) time mode may be selected on first line. When LCL time mode is selected, hours and minutes offset from UTC may be entered on second line.

3-2.3 Setup Menus and Screens (cont'd)

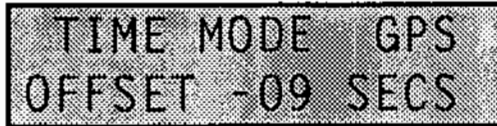

A rectangular box containing two lines of text. The first line reads "TIME MODE GPS" and the second line reads "OFFSET -09 SECS".

Figure 3-18B. Setup Screen 06 -TIME MODE SEL - GPS, Seconds Offset Select

When GPS time mode is selected, the GPS offset (in seconds) is entered on second line.

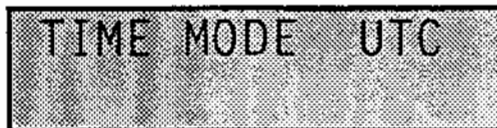

A rectangular box containing one line of text: "TIME MODE UTC".

Figure 3-18C. Setup Screen 06 - TIME MODE SEL- UTC Select

When UTC time mode is selected, the second line of the setup screen is blank.

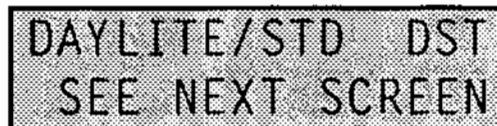

A rectangular box containing two lines of text. The first line reads "DAYLITE/STD DST" and the second line reads "SEE NEXT SCREEN".

Figure 3-19. Setup Screen 07 - DAYLITE/STD Select

Selects Daylight Savings Time or local STanDard time. If Daylight Savings time is selected, Spring and Fall dates must be entered in Setup Screen 08. When Daylight is selected, rollover of one hour is automatic on the date selected.



A rectangular box containing two lines of text. The first line reads "SPRNG DATE 04-07" and the second line reads "FALL DATE 10-28".

Figure 3-20. Setup Screen 08 - SET D/S DATES

Sets Spring and fall daylight savings dates. This setup is not required if Local Standard time is selected using Setup Screen 07.

3-2.3 Setup Menus and Screens (cont'd)

```
SEL HI RATE OUT
      10 MPPS
```

Figure 3-21. Setup Screen 09 - High RATE SEL

Sets rear-panel high frequency rate output BNC connector J15 to **1, 5, or 10 MPPS**.

```
SEL LO RATE OUT
      100 PPS
```

Figure 3-22. Setup Screen 10 - LOW RATE SEL

Sets rear-panel low frequency **RATE OUT**put BNC connector J16 to 1 PPH, 6 PPH, 12 PPH, 1 PPM, 1PPS, 10PPS, 100PPS, 1KPPS, 10KPPS, 100KPPS, or 1 MPPS.

```
RS232A BAUD 4800
BITS 8 PAR NONE
```

Figure 3-23. Setup Screen 11 - RS-232 A FORMAT

Sets RS-232A communications port parameters (baud rate, number of data bits and parity).

Available baud rates: 300, 600, 1200, 2400, 4800, 9600,19.2K
 Available data bits: 7 or 8
 Available parity: odd, even, none

```
RS232A DSR DSABL
MSG RATE:REQUEST
```

Figure 3-24. Setup Screen 12 - RS-232 A SETUP

First line selects DSR (Data Set Ready). Second line selects time output once a second or by request only.

3-2.3 Setup Menus and Screens (cont'd)



```
RS232B BAUD 1200
BITS 8 PAR NONE
```

Figure 3-25. Setup Screen 13 - RS-232 B FORMAT

Sets RS-232B communications port parameters (baud rate, number of data bits and parity).

Available baud rates: 300, 600, 1200, 2400, 4800, 9600, 19.2K
Available data bits: 7 or 8
Available parity bits: odd, even, none



```
RS232B DSR DSABL
MSG OUT: DSABL
```

Figure 3-26. Setup Screen 14 - RS-232 B SETUP

First line selects DSR (Data Set Ready). Second line enables or disables logged time output. When enabled, single-line time output is printed once per minute. Selects time output once a minute or by request only.

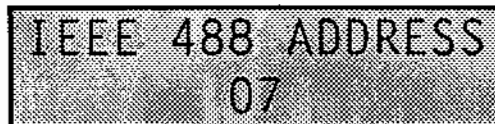

```
IEEE 488 ADDRESS
07
```

Figure 3-27. Setup Screen 15 - IEEE ADDRESS

Sets IEEE-488 address (00 thru 30). This screen appears even if IEEE-488 option is not installed.

CAUTION: Entering a number greater than 30 inhibits the user from exiting the screen.

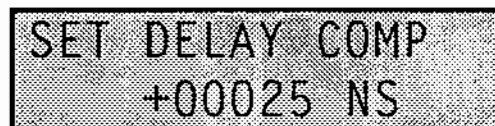

```
SET DELAY COMP
+00025 NS
```

Figure 3-28. Setup Screen 16 - DeLaY COMPensation SET

Under normal operating conditions, delay compensation in nanoseconds is positive and is equal to the antenna cable length in meters multiplied by 5.06 for RG-58 or RG-213 cable. It can be further adjusted to cause the 1 PPS output to align with an external 1 PPS reference within the limits of ± 99999 ($\pm 99.999 \mu\text{sec}$). Refer to Table 3-1 for the delays associated with the most common coaxial cables used with the Model 8820A.

3.2.3 Setup Menus and Screens (cont'd)

Table 3-1. Antenna Cable Delay Specifications

CABLE TYPE	DELAY/FOOT	DELAY/METER
RG-58	1.54 nsec	5.06 nsec
RG-213	1.54 nsec	5.06 nsec
9913 (Belden)	1.21 nsec	3.97 nsec
LDF4-50A (Andrews)	1.15 nsec	3.97 nsec
LDF5-50A (Andrews)	1.14 nsec	3.75 nsec

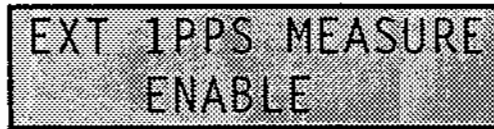

Figure 3-29. Setup Screen 17 - INT/EXT 1 PPS SEL

Enables 1PPS Input Time Interval Measurement. When this feature is enabled, Status Screen 9 displays time interval measurement (in nanoseconds) between the 1 PPS reference signal applied at rear-panel 1 PPS IN BNC Connector J18 and internal 1 PPS (UTC) signal.

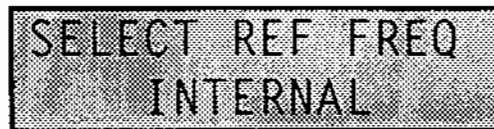

Figure 3-30. Setup Screen 18 - REF FREQ SELECT

CAUTION

Before selecting EXTERNAL frequency, refer to paragraph 1-8 and the NOTE after the 'Status Screen 8' figure. Selecting EXTERNAL without applying a signal will *DISABLE* the Model 8820A .

Selects INTERNAL disciplined oscillator or EXTERNAL input reference frequency for operating unit. EXTERNAL input selections are 1 MHz, 5 MHz, 10 MHz.

3.2.3 Setup Menus and Screens (cont'd)



Figure 3-31. Setup Screen 19 - INitiate GPS START

Note: This setup is non-mandatory. Start modes are defined at the end of this paragraph.

The start feature will speed up the acquisition of satellites if the unit:

- a) Has been moved over 600 km while not operating - (Cold Start).
- b) The unit has been out of service for over 6 months - (Cold Start).
- c) Battery BAT1 on Main Logic Assembly A1 has discharged or been removed when power is off - (Cold Start).
- d) The unit has been operated for more than 5 minutes without an antenna - (Warm Start).

The default start mode on power-up is 'Warm Start'. After power up, the GPS Receiver validates the almanac, position, date, and time. If successful, it proceeds with a 'Warm Start'. If, after 30 minutes, the GPS Receiver has not acquired a minimum of two satellites, it assumes that the position, date, and time are incorrect and proceeds to a 'Cold Start'. These terms are defined below.

Setup Screen 19 allows the user to command the GPS Receiver to start in one of two modes; 'Warm' or 'Cold'. The GPS Receiver terminates current operation and starts in the new selected mode when this setup is executed. Selection is accomplished by selecting one of the two modes and setting the 'DISABLE' message to 'ENABLE'. Execution of this command is accomplished by leaving the Setup Screen.

DEFINITIONS:

Warm Start - This is the unit's default mode when it is first powered up with an antenna properly positioned. After power-up, the unit goes through a validation sequence and normally completes Warm Start within two minutes. If the unit has not acquired at least two satellites after 30 minutes, it assumes that position, date, and time are incorrect and it moves to the 'Cold Start' mode.

Cold Start - This is a "last resort" mode to be used if the unit has insufficient retained satellite data or if internal communication between the Model 8820A and its built-in receiver have broken down. Select this mode if the unit cannot complete a successful start after 30 minutes in Warm Start. Also use this method for the first start after the GPS receiver or internal memory backup battery has been replaced. A Cold Start command completely clears all receiver memory, causing it to search for all 36 possible satellites, at all ranges.



Figure 3-32. Setup Screen No. 20 - Set Timeout

Allows user to set timeout period from 00 to 99 minutes before unit reports an unlock condition on rear-panel STATUS output. Prevents activity on STATUS line during initialization and acquisition. As shown in Table 3-4, the factory default is 10 minutes.

3-3 REMOTE OPERATION

The Model 8820A can be remotely operated using the supplied RS-232A interface or, when ordered, an optional IEEE-488 interface. These two interfaces *cannot* be commanded simultaneously.

All requests and commands initiated by the HOST computer must be terminated by a carriage return <CR>. The Model 8820A 's response includes a carriage return <CR> and a line feed (<LF>) in a RS-232 interface and a <LF>/End Of Identify <EOI> character in an IEEE-488 interface. The remote (HOST), equipment should be set to read responses until the <CR><LF> (RS-232) or <LF>/EOI (IEEE-488) combination is detected.

3-3.1 RS-232 Operation

The Model 8820A can be operated from a remote computer or terminal using RS-232A Port J11. The two remote operating modes provided for this port are:

3-3.1.1 Computer Mode

The Computer Mode is the default mode of RS-232A communications port and is the mode used when controlling the Model 8820A from a remote computer. No echoing of input commands is given, and the once-per-second time output, if commanded, is active. When writing interface programs, do not issue three or more successive carriage return <CR>, <CR>, <CR>, commands. This will switch the port communications mode to Local Echo. To reenter the Computer Mode after using the Local Echo mode, issue a control E (^E).

3-3.1.2 Local Echo Mode

Use this mode when controlling the Model 8820A from a terminal keyboard. Enter the Local Echo Mode by typing three successive carriage returns <CR>. A '8820A >' prompt is displayed when in this mode, and all input keystrokes are echoed to the screen. While in the Local Echo mode, once-per-second time outputs from this port are suspended. To exit this mode, type a control E (^E).

NOTE

Before attempting to use the RS-232A port, assure that the remote computer or terminal and the Model 8820A are set to the same baud rate and serial-data format. Configure Model 8820A 's RS232A port, J11, using Setup Screens 11 & 12.

All requests and commands are initiated from the host computer or terminal. All entries must be terminated with a carriage return <CR>. The 8820A 's response ends with a carriage return <CR> and line feed <LF>. A command on the IEEE-488 interface terminates in an End of Identity <EOI> character or a <CR><LF>. The Model 8820A's Remote Time Request, Status Request, and Setup Command data formats are described in Paragraph 3-4 below.

3-3.2 IEEE488 Operation

When the IEEE Option is installed, the Model 8820A can be operated from a remote computer using an IEEE-488 GPIB (General Purpose Interface Bus). A received line-feed (<LF>) character is accepted, but ignored by the Model 8820A .

NOTE

There are some Model 8820A multi-line responses that have lines terminated in <CR>/<LF>without EOI.

3-4 REMOTE COMMANDS

3-4.1 Remote Time Requests

Time-tagging accuracy in this mode is approximately 50 milliseconds, depending on baud rate and internal CPU activity. Time is tagged zero to 50 ms after the end of the input request message. Time outputs are resolved to 10 milliseconds. To obtain more accurate time output, select the Once-Per-Second auto-timed output for J11 using RS-232 Setup Screen 12.

Request UTC Time

Host sends: RQUT<CR>

8820A replies: RQUT ddd:hh:mm:ss.ff0,Q<CR><LF>

where:

ddd = day of year
 hh = hours
 mm = minutes
 ss = seconds
 ff0 = milliseconds with 10 ms resolution.
 Q = Quality byte :
 0 = Unknown
 9 = Phase > 5 ms
 8 = Phase < 5 ms and > 1ms
 7 = Phase < 1 ms and >100 μ s
 6 = Phase < 100 μ s and >10 μ s
 5 = Phase < 10 μ s and > 1 μ s
 4 = Phase < 1 μ s and >100 ns
 3 = Phase < 100 ns >10 ns
 2 = Phase < 10 ns and >1 ns
 1 = Phase = 1 ns or less

Request LOCAL Time

Host Sends: RQLT<CR>

8820A replies: RQLT yyyy,MM,dd,hh:mm:ss.ff0,Q<CR><LF>

where:

yyyy = year; e.g. 1991
 MM = month
 dd = day of month
 others: as previously described

Request GPS Time

Host Sends: RQGT<CR>

8820A replies: RQGT yyyy,MM,dd,hh:mm:ss.ff0,Q<CR><LF>

where:

yyyy = year; e.g. 1991
 MM = month
 dd = day of month
 others: as previously described

3-4.1.1 Continuous Time Output

This command sets up the Model 8820A to output time once per second. The command is accepted in either the Local Echo Mode or the Computer Mode; however, outputs are suspended as long as the unit is in the Local Echo Mode.

The message output has a resolution of one second. The start of transmission is denoted by the "*" (on time mark) prior to the "RQTS"....." output. The specifications on this output are shown in the following table. The accuracy specifications of the "on time mark" are in reference to the 1 PPS output.

Table 3-2. Time Mark Accuracy

		* →	LF
BAUD RATE	ACCURACY (μsec)	NOM (ms)	MAX (ms)
300	500-700	850	---
600	300-400	440	---
1200	200-250	220	---
2400	150-200	105	---
4800	110-120	55	70
9600	95-100	30	40
19,200	95-100	18	20

NOTE 1: 100 microseconds accuracy is valid only if no other RS-232 commands are being currently processed.

NOTE 2: 1 PPS time output is not available on IEEE-488.

Host sends: RQTS +CR or RQTS,U<CR> (to select UTC)
or
RQTS,L<CR>(to select local time)

8820A replies: *RQTS U,ddd:hh:mm:ss,O,Q<CR><LF> (for UTC)
or
*RQTS L,ddd:hh:mm:ss,O,Q<CR><LF> (for Local)

where: ddd = day of year, hh = hours, mm = minutes, and ss = seconds

- Q = Quality byte :
- 0 = Unknown
 - 9 = Phase > 5 ms
 - 8 = Phase < 5 ms and >1 ms
 - 7 = Phase < 1 ms and >100 μs
 - 6 = Phase < 100 μs and >10 μs
 - 5 = Phase < 10 μs and >1 μs
 - 4 = Phase < 1 μs and >100 ns
 - 3 = Phase < 100 ns >10 ns
 - 2 = Phase < 10 ns and >1 ns
 - 1 = Phase = 1 ns or less

3-4.1.1 Continuous Time Output (continued)

To terminate requests:

Host sends: RQTX<CR>
8820A replies: RQTX DONE<CR><LF>

3-4.2 Remote Status Requests

The following paragraphs describe the Remote Status Request Commands.

Request tracking/locked status -

Host sends: RQLK<CR>
8820A replies: RQLK NO LOCK SINCE POWERUP<CR><LF>
RQLK FREE RUN SINCE ddd:hh:mm:ss <CR><LF> or
RQLK LOCKED SINCE ddd:hh:mm:ss<CR><LF>

Request current time offsets values -

Host sends: RQTO<CR>
8820A replies: RQTO UTCshh,mm DST+h<CR><LF>
where: s = signed hours (range is -12 to +12) of Local Time Offset
mm = minutes of Local Time Offset
+h = is either "+0" or "+1" hours of Daylight Saving Time Offset

Request leap second status -

Host sends: RQLS<CR>
8820A replies: RQLS yy,mm,dd<CR><LF>
where: yy = year; e.g. 1994
mm = month
dd = day of month

Note: Default is all zeros

Request current time code output format -

Host sends: RQTC<CR>
8820A replies: RQTC string<CR><LF>
where: string is IRIG, 2137, or NASA 36

3-4.2 Remote Status Requests (continued)

Request current frequencies and rates selected -

Host sends: RQFR<CR>

8820A replies: RQFR fi, fo, pp<CR><LF>

where: fi (freq in) is: "INTERNAL", "EXT *1 MHZ",
"EXT 5 MHZ", or "EXT 10MHZ"

fo (Hi Rate Out) is: "1M PPS", "5M PPS", "10M PPS"

pp (Lo Rate Out) is: "1 PPS", "10 PPS", "100 PPS",
"1K PPS", "10K PPS", "100 KPPS",
"1M PPS", "1 PPH", "6 PPH", "12 PPH", or
"1 PPM"

Request list of selected satellites-

Host sends: RQSS<CR>

8820A replies: RQSS svh,svh,svh, ..svh,svh,svh<CR><LF>
or RQSS NONE<CR><LF>

where: sv - is the satellite PRN number
h - is an "H" for a healthy satellite and
h - is a "U" for a unhealthy satellite
h - is a "+" for a forced healthy satellite
h - is an "X" for an illegal response
h - is a "?" for an uninitialized value

Request list of satellites being tracked -

Host sends: RQST<CR>

8820A replies: RQST sv,sv,sv,sv,sv,sv <CR><LF>or RQST NONE<CR><LF>

Request last navigation data -

Host sends: RQLN<CR>

8820A replies: RQLN dd:mm.fffN,ddd:mm.fffW,Shhhhh.f<CR><LF>

where: dd:mm.fffN is Latitude, where N is North or S is South.
ddd:mm.fffW is Longitude, where W is West or E is East.
Shhhhh.f is Height in meters.

where: S =+ (positive) or - (negative) elevation

3-4.2 Remote Status Requests (continued)

Request position data being used (fixed position mode)-

Host sends: RQLP<CR>

8820A replies: RQLP dd:mm.fffN,ddd:mm.fffW,Shhhhh.f<CR><LF>

where: dd:mm.fffN is Latitude, where N is North, or S is South
ddd:mm,fffW is Longitude, where W is West, or E is East
Shhhhh.f is Height in meters

where: S = + (positive) or - (negative) elevation

Request position mode -

Host sends: RQNM<CR>

8820A replies: RQNM M<CR><LF>

where: M is an "A" if Auto tracking
is a "D" if Dynamic navigation
is an "F" is Fixed Position

Request difference between the time reference and the measurement reference -

Host sends: RQIR<CR>

8820A replies: RQIR ttt, REF - mmm, "string"<CR><LF>

where: ttt (time ref) is "INT" if internal reference or "EXT" if external reference,
mmm (measurement ref) is "UTC" or "GPS"
string" is either the difference (in nanoseconds) or a status message.

Request Satellite Position and Dilution of Precision (DOP) Values -

Host sends: RQSD<CR>

8820A replies: RQSD PRN sv, AZ=aaa, EL =ee, SN =ss.s<CR><LF>*
NDOP = XXX.X EDOP = XXX.X VDOP = XXX.X,
HDOP=XXX.X<CR><LF>

(* This line is repeated for each satellite currently being tracked.)

where: sv is the satellite PRN number
aaa is the azimuth in degrees
ee is the elevation in degrees
ss.s is the signal to noise ratio
XXX.X is the appropriate dilution of precision

3-4.2 Remote Status Requests (continued)

Request daylight savings or standard time mode -

Host sends: RQDS<CR>
 8820A replies: RQDS m<CR><LF>
 where: m is "D" if Daylight or "S" if standard

Request DAC reference value -

Host sends: RQDR<CR>
 8820A replies: RQDR dddd<CR><LF>
 where: dddd is DAC setting

Request firmware data -

Host sends: RQBS<CR>
 8820A replies: RQBS 80188=AAAAA 6811=BBBBB 6805=CCCCC<CR><LF>
 RCVR1=DDDD RCVR2=EEE<CR><LF>
 where: AAAAA, BBBBB and CCCCC are the firmware versions of the EPROMS
 on the main logic board.
 DDDD and EEE are the firmware version of the GPS Receiver

3-4.3 Remote Setup Commands

The following paragraphs describe the Remote Setup Commands. All Setup commands perform dual functions. When terminated with a NULL string, the value the parameter is set to in the 8820A is returned to the host. When terminated with a valid string, appropriate parameter is set in the 8820A to the value specified by the host.

SET/REQUEST UTC time - (Optional). This command is never required but is provided to allow the unit to be used as a time code generator, without the need of a satellite.

Request mode:

Host sends: SUT<CR>
 8820A replies: SUT ddd:hh:mm:ss.ff0,Q<CR><LF>
 where: ddd = day of year
 hh = hours
 mm = minutes
 ss = seconds
 ff0 = milliseconds with 10 ms resolution
 (Third character is always a zero)

3-4.3 Remote Setup Commands (cont'd)**SET/REQUEST UTC time****Request mode: (cont'd)**

where: Q = Quality byte :

- 0 = Unknown
- 9 = Phase > 5 ms
- 8 = Phase < 5 ms and >1 ms
- 7 = Phase < 1 ms and >100 μ s
- 6 = Phase < 100 μ s and >10 μ s
- 5 = Phase < 10 μ s and >1 μ s
- 4 = Phase < 1 μ s and >100 ns
- 3 = Phase < 100 ns >10 ns
- 2 = Phase < 10 ns and >1 ns
- 1 = Phase = 1 ns or less

Set mode:**Host sends:** SUT yyyy,MM,dd,hh,mm,ss<CR>

where: yyyy = year; e.g. 1991
MM = month
dd = day of month
others: as previously described

8820A replies: SUT DONE<CR><LF>(After 8820A has completed task).**SET/REQUEST time mode -****Request mode:****Host sends:** STM<CR>**8820A replies:** STM m,ooo, mm<CR><LF>

where: m - is a "G" if GPS
 m - is a "U" if UTC
 m - is a "L" if LOCAL
 ooo - is the signed offset value in hours (\pm HH) for Local seconds for GPS offset.
 mm - is the offset in minutes (0-59) for Local

Set mode:**Host sends:** STM m,ooo,mm<CR>

where: m - is a "U" for UTC
 m- is a "G" for GPS
 m - is an "L" for Local
 ooo - is the signed offset value in hours (\pm HH) for Local seconds for GPS offset.
 mm is the offset in minutes (0-59) for Local

8820A replies: STM DONE<CR><LF>(After 8820A has completed task).

3-4.3 Remote Setup Commands (cont'd)

SET/REQUEST DST dates -

Request mode:

Host sends: SDD<CR>

8820A replies: SDD mm,dd,mm,dd,M<CR><LF>

where: 1st mm,dd - is Spring's date and
 2nd mm,dd - is Fall's date
 M is a "D" if daylight or an "S" if standard

Set mode:

Host sends: SDD mm,dd,mm,dd,M<CR>

where: 1st mm,dd - is Spring's date and
 2nd mm,dd - is Fall's date
 M is a "D" if daylight or an "S" if standard

8820A replies: SDD DONE<CR><LF>

SELECT/REQUEST desired satellites to be used. (Must use SV's PRN number) -

Request mode:

Host sends: SSV<CR>

8820A replies: SSV svh,svh,svh,... svh,svh,svh<CR><LF> or SSV NONE<CR><LF>

where: sv - is the satellite PRN number
 h - is an "H" for a healthy satellite and
 h - is a "U" for a unhealthy satellite
 h - is a "+" for a forced healthy satellite
 h - is a "-" for a forced unhealthy satellite
 h - is a "X" for an illegal response
 h - is a "?" for an uninitialized value

3-4.3 Remote Setup Commands (cont'd)

SELECT/REQUEST desired satellites to be used. (Must use SV's PRN number) -

Set mode:

Host sends: SSV m,sv,sv,sv<CR>

where: m - is an "N" or 00 to set all satellites to a natural state
is an "A" to force satellites indicated healthy
is an "R" to force satellites indicated unhealthy
is an "O" to force the 8820A to track only reference satellites (all other forced unhealthy)
is an "S" to force the 8820A to track a single reference satellite. This mode allows the unit to use a single satellite for time recovery while continuing to track up to five other satellites. Execution of this command will cause the navigation mode to switch to fixed position. When a "SSVS00" command is executed, the single satellite mode is suspended and the unit is placed in normal fixed position operation.
sv - is (are) the referenced satellite number(s)

8820A replies: SSV DONE<CR><LF>

SELECT/REQUEST desired satellites to be used. (Must use SV's PRN number) -

NOTICE NOTICE NOTICE NOTICE NOTICE NOTICE

If power is interrupted to the 8820A when the single satellite tracking mode is being used, once power has been reestablished, the unit attempts to start tracking the same satellite it was tracking prior to the loss of power. Since this satellite may no longer be in view, the 8820A may fail to establish a locked condition. To insure that this does not happen, the operator should re-issue the "SSV S sv" command, with the appropriate satellite referenced, as soon as the 8820A is returned to a powered condition.

SELECT/REQUEST references -

Request mode:

Host sends: STR<CR>

8820A replies: STR r,s,ff<CR><LF>

where: r - is a "U" for UTC
s - is a "I" for internal reference or is an "E" for external reference.
ff - is 01, 05, or 10. (external reference input frequency)

3-4.3 Remote Setup Commands (cont'd)

SELECT/REQUEST references -

Set mode:

Host sends: STR r,s,ff<CR>

where: r - is a "U" for UTC
s - is a "I" for internal reference or is an "E" for external reference.
ff - is 01, 05, or 10. (external reference input frequency)

8820A replies: STR DONE<CR><LF>

SELECT/REQUEST time code -

Request mode:

Host sends: STC<CR>

8820A replies: STC string<CR><LF>

where: string is "IRIG B", "2137" or "NASA 36"

Set mode:

Host sends: STC c<CR>

where: c - is a "B" for IRIG B time code,
c - is a "2" for 2137 time code or
c - is an "N" for NASA 36 BIT time code.

8820A replies: STC DONE<CR><LF>

SELECT/REQUEST rate output -

Request mode:

Host sends: SRO<CR>

8820A replies: SRO string<CR><LF>

where: string - is "1PPS", "10PPS", "100PPS", "1KPPS", "10KPPS",
"100 KPPS", "1M PPS", "1PPM", "1PPH", "6PPH", or "12PPH"

3-4.3 Remote Setup Commands (continued)

SELECT/REQUEST rate output (continued)

Set mode:

Host sends: SRO, string<CR>

where: string - is "1PPS", "10PPS", "100PPS", "1KPPS", "10KPPS", "100KPPS", "1MPPS", "1PPM", "1PPH", "6PPH", or "12PPH"

8820A replies: SRO DONE<CR><LF>

SELECT/REQUEST Frequency output -

Request mode:

Host sends: SFO<CR>

8820A replies: SFO ff<CR><LF>

where: ff - is 01, 05, or 10 (MPPS)

Set mode:

Host sends: SFO, ff<CR>

where: ff is 01, 05, or 10 (MPPS)

8820A replies: SFO DONE<CR><LF>

SET/REQUEST local position -

Request mode:

Host sends: SLP<CR>

8820A replies: SLP dd:mm.fffN,ddd:mm.fffW,Shhhhh.f<CR><LF>

where: dd:mm.fff is Latitude (N is North or S is South)
 ddd:mm.fff is Longitude (W is West or E is East)
 Shhhhh.f is Height in meters
 where S = + (positive) or- (negative) elevation

Set mode:

Host sends: SLP dd:mm.fffN,ddd:mm.fffW,Shhhhh.f<CR>

where: dd:mm.fff is Latitude (N is North or S is South)
 ddd:mm.fff is Longitude (W is West or E is East)
 Shhhhh.f is Height in meters
 where S = + (positive) or- (negative) elevation

8820A replies: SLP DONE<CR><LF>

3-4.3 Remote Setup Commands (cont'd)

SET/REQUEST position mode -

Request mode:

Host sends: SNM<CR>

8820A replies: SNM m<CR><LF>

where: m - is an "A" if auto tracking
 m - is a "D" if dynamic navigation
 m - is an "F" if fixed position

Set mode:

Host sends: SNM m<CR>

where: m - is an "A" if auto tracking
 m - is a "D" if dynamic navigation
 m - is an "F" if fixed position

8820A replies: SNM DONE<CR><LF>

SET/REQUEST 1 PPS source -

Request mode:

Host sends: SPP<CR>

8820A replies: SPP S<CR><LF>

where: S = is a "D" to disable 1 PPS measurement (ext. reference - UTC reference)
 S = is a "E" to enable 1 PPS measurement (ext. reference - UTC reference)

Set mode:

Host sends: SPP S<CR>

where: S = is a "D" to disable measurement (ext. reference - UTC reference)
 S = is a "E" to enable measurement (ext. reference - UTC reference)

8820A replies: SPP DONE<CR><LF>

3-4.3 Remote Setup Commands (cont'd)

SET/REQUEST RS-232B Port parameters and output rate -

Request mode:

Host sends: SPR<CR>

8820A replies: SPR bb, p, d, D<CR><LF>

where:

- bb is 03 if 300 baud
- bb is 06 if 600 baud
- bb is 12 if 1200 baud
- bb is 24 if 2400 baud
- bb is 48 if 4800 baud
- bb is 96 if 9600 baud
- bb is 19 if 19.2K baud
- p is an "O" if odd parity
- p is an "E" if even parity
- p is an "N" if no parity
- d is a "7" if seven data bits or "8" if eight data bits
- D is a "D" if DSR disabled or "E" if DSR enabled

Set mode:

Host sends: SPR bb,p,d,D, o, mm<CR>

where:

- bb is 03 if 300 baud
- bb is 06 if 600 baud
- bb is 12 if 1200 baud
- bb is 24 if 2400 baud
- bb is 48 if 4800 baud
- bb is 96 if 9600 baud
- bb is 19 if 19.2K baud
- p is an "O" if odd parity
- p is an "E" if even parity
- p is an "N" if no parity
- d is a "7" if seven data bits or "8" if eight data bits
- D is a "D" if DSR disabled or "E" if DSR enabled
- o is an "L" to enable print out logs
- o is a "D" to disabled print out logs
- o is an "R" to print full page status report
- mm is log interval in minutes

8820A replies: SPR DONE<CR><LF>

3-4.3 Remote Setup Commands (cont'd)

SET/REQUEST minimum tracking elevation -

Request mode:

Host sends: SEL<CR>

8820A replies: SEL eee<CR><LF>

where: eee is the minimum elevation in degrees

Set mode:

Host sends: SEL eee<CR>

where: eee is the new minimum elevation in degrees

8820A replies: SEL DONE<CR><LF>

SET/REQUEST delay compensation -

Request mode:

Host sends: SDC<CR>

8820A replies: SDC snnnnn<CR><LF>

where: S is the sign (+/-)
nnnnn is the nanoseconds delay; eg., 65 ns delay = 00065
(Range is $\pm 99.999 \mu\text{sec.}$)

Set mode:

Host sends: SDC Snnnnn <CR>

where: S is the sign (+/-)
nnnnn is the nanoseconds delay; e.g., 65 ns delay is entered as 00065
(Range is $\pm 99.999 \mu\text{sec.}$)

8820A replies: SDC DONE<CR><LF>

START command

Request mode: (there is no request mode)

Set mode:

Host sends: SST X<CR>

Where: X is C for a Cold Start
X is W for a Warm Start

8820A replies: SST DONE<CR><LF>

3-4.4 Printed Logged Data Output Description

The printed single-line logged data output messages briefly describes the tracking status of the Model 8820A. Table 3-3 describes the function of each character position in the format of the logged data output message.

Table 3-3. Logged Data Output Message Format

CHARACTER POSITION	DESCRIPTION
1-9	Time - DDD:HH:MM
10	Blank
11	Mode - 'F' for FIXEd POSition, "A" for AUTOMatic Tracking and "D" for DYNamic NAVagation
12	UTC - "U" LOCAL - "L"
13	Oscillator Status - "L" for locked; "F" for free running
14	Blank
15-18	DAC value
19-26	Blank
27-32	UTC minus GPS in nsec "xxxxxxxxxx NS"
33	Blank
34	Number of satellites visible
35	Blank
36	Number of satellites being tracked
37-38	Blank
39-40	PRN of 1st satellite being tracked
41	Blank
42-43	PRN of 2nd satellite being tracked
44	Blank
45-46	PRN of 3rd satellite being tracked
47	Blank
48-49	PRN of 4th satellite being tracked
50	Blank
51-52	PRN of 5th satellite being tracked
53	Blank
54-55	PRN of 6th satellite being tracked
56	Blank
57-61	NDOP
62	Blank
63-67	EDOP

3-4.4 Printed Logged Data Output Description

The printed single-line logged data output messages briefly describes the tracking status of the Model 8820A. Table 3-3 describes the function of each character position in the format of the logged data output message.

Table 3-3. Logged Data Output Message Format

CHARACTER POSITION	DESCRIPTION
1-9	Time - DDD:HH:MM
10	Blank
11	Mode - 'F' for FIXEd POSition, 'A' for AUTOMatic Tracking and 'D' for DYNamic NAVagation
12	UTC - 'U' LOCAL - 'L'
13	Oscillator Status - 'L' for locked; 'F' for free running
14	Blank
15-18	DAC value
19-26	Blank
27-32	UTC minus GPS in nsec "xxxxxxxxxx NS"
33	Blank
34	Number of satellites visible
35	Blank
36	Number of satellites being tracked
37-38	Blank
39-40	PRN of 1st satellite being tracked
41	Blank
42-43	PRN of 2nd satellite being tracked
44	Blank
45-46	PRN of 3rd satellite being tracked
47	Blank
48-49	PRN of 4th satellite being tracked
50	Blank
51-52	PRN of 5th satellite being tracked
53	Blank
54-55	PRN of 6th satellite being tracked
56	Blank
57-61	NDOP
62	Blank
63-67	EDOP

Table 3-3. Logged Data Output Message Format (continued)

CHARACTER POSITION	DESCRIPTION
68	Blank
69-73	VDOP
74	Blank
75-79	HDOP
80	Blank

3-4.5 Printed Status Report

A status report describing the detailed operating parameters of the Model 8820A is output to the printer port when requested by a remote terminal or computer. A typical status report printout is shown in Figure 3-33. Figure has been reduced so that the entire report is presented on this page.

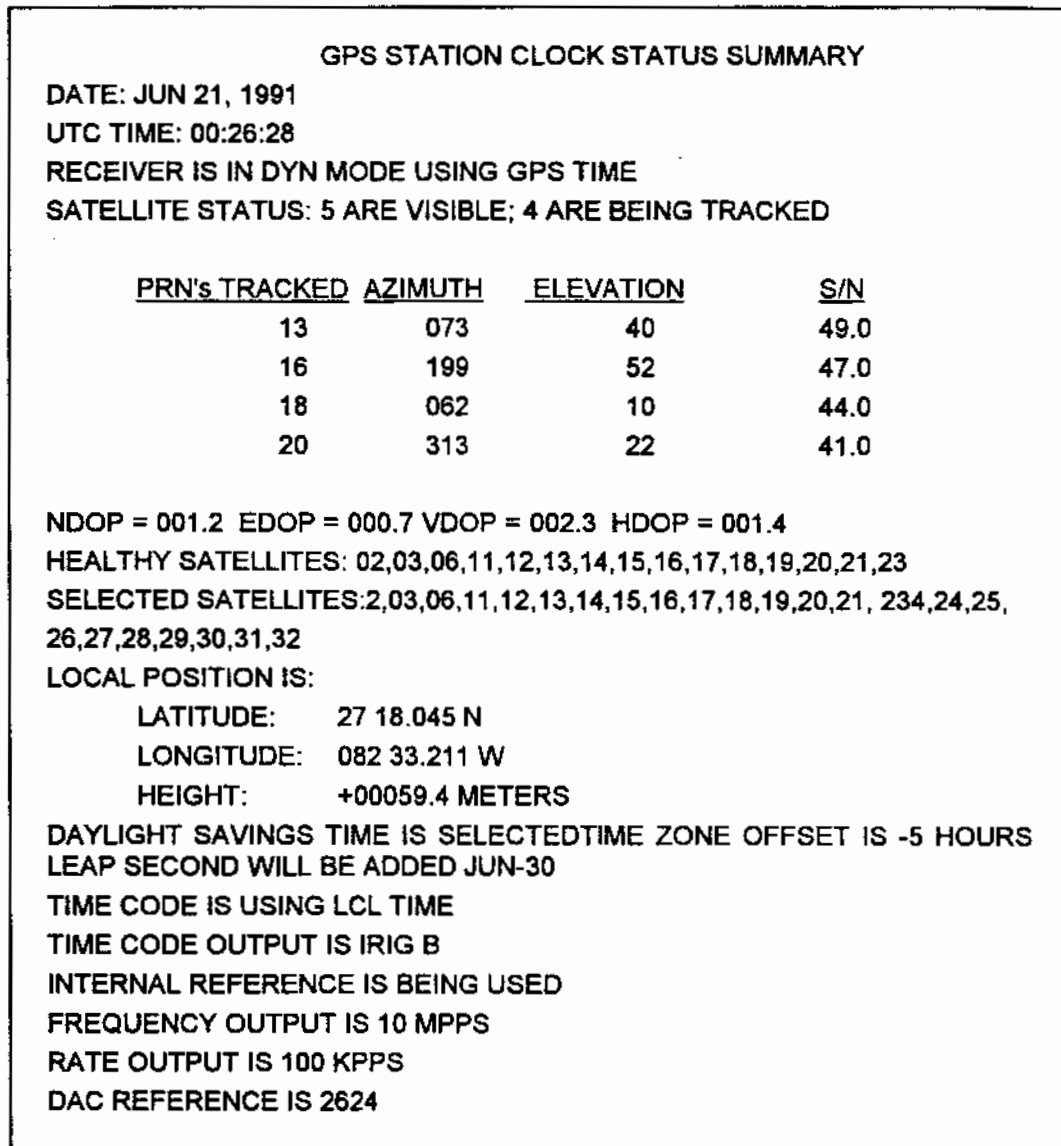

Figure 3-33. GPS Station Clock Printed Status Report

3-5 FACTORY SETTINGS

When your Model 8820A has not been factory configured by TRAK to your specifications, your instrument is shipped with the factory-set operating parameters listed in Table 3-3. Sequentially step through each Setup Screen and compare the factory settings with your desired operating parameters. Referring to Paragraph 3.2.4, Setup Screens, enter data as required.

CAUTION

It is very important that you understand the significance of changing an operating parameter before actually doing so. Failed acquisition and tracking of satellites may result when erroneous data are input. It is suggested that you read Appendix D to this manual giving an overview of the GPS Satellite System and read through the descriptive information provided with each Setup Screen before entering new Setup data. Refer to Appendix A, GPS Glossary and Abbreviations, for explanations of terms not described in the body of the manual.

Table 3-4. Model 8820A Factory Settings

SETUP SCREEN		FACTORY SETTING	CUSTOMER SETTING
NO.	NAME		
00	Reserved for factory test		
01	SELECT POSITION MODE	DYNAV	
02	SET ANTENNA POSITION	LATITUDE: 00 00.000 N LONGITUDE: 000 00.000 W	
03	SET ANTENNA HEIGHT	HEIGHT: -00018.0 METERS	
04	TIME CODE SEL	IRIG B	
05	TIME SET	On startup, this screen has no significance. After a group of satellites is acquired, the UTC time is automatically set to present time. MM/DD/YY HH:MM:SS	
06	TIME MODE SELECT	UTC	
07	DAYLIGHT/STD	DAYLIGHT SAVINGS SPRING DATE: 04-01 FALL DATE: 10-28 (These are typical dates with no special meaning. Current dates for your area must be set in.)	
09	HIGH RATE SEL	10 MPPS	
10	LOW RATE SEL	10 PPS	

Table 3-4. Model 8820A Factory Settings (continued)

SETUP SCREEN		FACTORY SETTINGS	CUSTOMER SETTINGS
	NAME		
11	SET RS-232A INTER- FACE FORMAT	BAUD RATE: 9600 DATA BITS: 8 PARITY: NONE	
12	RS-232 A TIME OUT	DSR: DISABLE UTC and BY REQUEST ONLY	
13	SET RS-232 B INTERFACE FORMAT	BAUD RATE: 1200 DATA BITS: 8 PARITY: NONE	
14	RS-232 B OUTPUT	DSR: DISABL MESSAGE OUT: DISABL	
15	IEEE-488 INTERFACE ADDRESS	ADDRESS IS 07. (IEEE-488 is an optional feature).	
16	SET DELAY COMPENSATION	Equal to the delay of the cable be- tween the antenna and the Model 8820A 's internal GPS Receiver output. See Table 3-1 to compute antenna cable delay for cable lengths different from factory-sup- plied lengths. This value may be set anywhere between -99.999 and +99.999 μ sec allowing customer- specified offsets to be combined with cable delay values.	
17	EXT 1 PPS MEASURE	DISABLE	
18	REF FREQ SEL	INTERNAL	
19	INITiate GPS START	WARM DISABLE	
20	SET TIMEOUT	10 MINUTES	

CHAPTER 4

PRINCIPLES OF OPERATION

4-1 GENERAL

This chapter presents the principles of operation of the Model 8820A GPS Station Clock at the block diagram level. Detailed logic and schematic diagram discussions of Model 8820A operation below the assembly level are not provided since field maintenance of this instrument below the assembly level is not practical.

4-2 BLOCK DIAGRAM DISCUSSION

The Model 8820A, shown functionally in Figure 4-1, comprises a GPS Receiver, a System Processor, a Disciplined Frequency Subsystem, 1 PPS Reference Measuring Circuit, and Time Code and Rate Generators. A front-panel keypad and associated LCD/LED Displays are used to enter and display time and operational data.

When synchronizing, the GPS Receiver determines the position of the antenna by measuring the pseudo-range to four satellites and computes the position of these satellites using ephemeris data. The GPS Receiver computes antenna latitude, longitude, and height with a position accuracy of ± 10 meters, rms (without selective availability).

When the GPS Receiver is receiving and processing satellite data, the 1 PPS Measuring Circuits compare the received 1 PPS signal from the GPS Receiver with the 1 PPS signal from the Disciplined Frequency Subsystem. As long as the difference between the received 1 PPS signal from the GPS Receiver and the internally generated 1 PPS is less than 250 nanoseconds, the Systems Processor uses the difference between these signals to discipline the oscillator in the Disciplined Frequency Subsystem

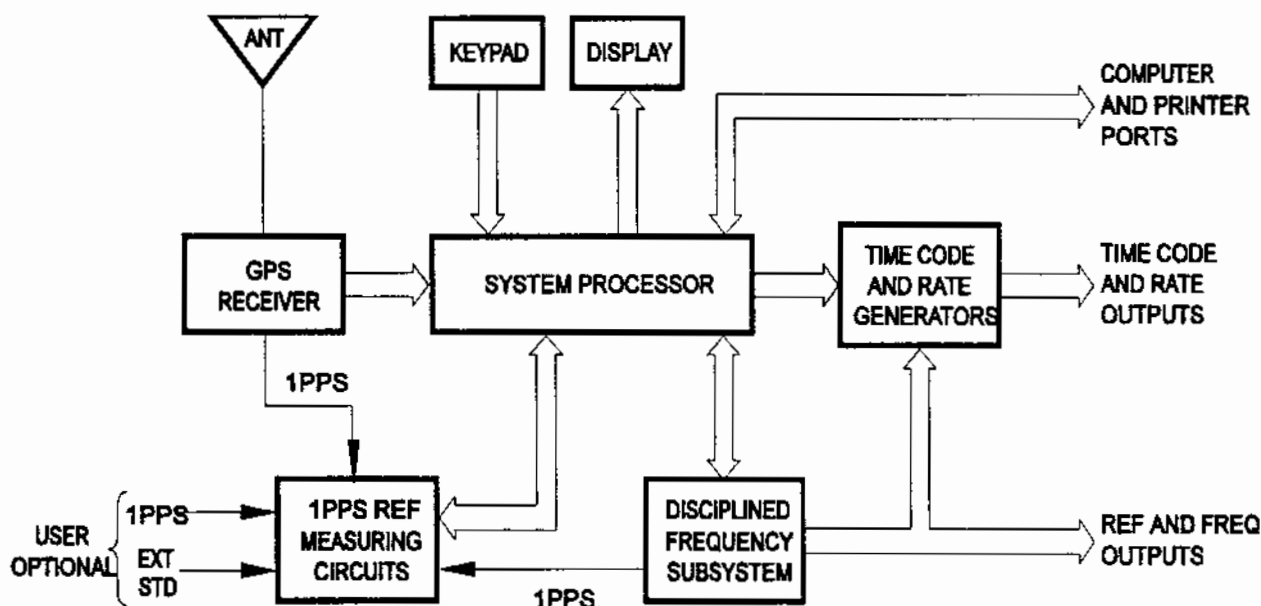

Figure 4-1. Model 8820A Block Diagram

4-2 BLOCK DIAGRAM DISCUSSION (cont'd)

During the time when no satellite is in view or being tracked, the Model 8820A operates on its internal oscillator and output time drift is less than one microsecond per hour with the internal crystal oscillator.

The Disciplined Frequency Subsystem provides corrected 1, 5, or 10 MHz reference frequency outputs to the Model 8820A rear-panel connectors and to the internal Time Code and Rate Generator circuits. The reference signal outputs are TTL levels into 50 ohms. The corrected 1 PPS output (accurate to within 300 nanoseconds of GPS) to the rear-panel 1 PPS OUTPUT connector is also at TTL levels into 50 ohms.

The Time Code and Rate Generator circuits output a keypad-selectable IRIG B, NASA 36-Bit, or 2137 serial modulated time code to CODE OUTPUT BNC connector J17 on the Model 8820A rear panel. The code amplitude level is internally adjustable from 1 to 5 volts peak-to-peak into 50 ohms with modulation ratios adjustable 2:1 to 6:1. Coherence to 1 PPS 'On Time' is less than 30 microseconds.

The basic Model 8820A provides one RS-232 computer I/O port for controlling the Model 8820A from a remote computer or dumb terminal. This interface responds to asynchronous commands of ASCII data at rates from 300 to 19.2K baud. This interface provides command echoing and facilities for requesting time and operational status outputs. A full set of status outputs is provided to completely depict system set up. Time tagging accuracy is: The start bit of the first serial time output character occurs within one millisecond of the leading edge of the 1 PPS OUTPUT at 8820A rear-panel jack J14.

The Model 8820A rear-panel RS-232 PRINTER port has the same parameters as the RS-232 I/O port, except it is transmit only. This port outputs a single-line logged status or a complete status report of Model 8820A operating parameters to an external printer.

CHAPTER 5

ROUTINE MAINTENANCE

5-1 GENERAL

Maintenance of the Model 8820A consists mainly of cleaning and general inspection to maintain the best environment for equipment operation. Routinely, check the instrument to assure that there is no loose hardware on front and rear panel components or on internal assemblies.

5-2 CLEANING SOLVENTS

Use only alcohol or water-based cleaners on the front and rear-panel areas. Other solvents may damage the keys, display, and/or markings.

5-3 ADJUSTMENTS

The Model 8820A adjustments are located on the individual internal assemblies of the instrument and have been factory set for optimum performance. The following paragraphs provide adjustment procedures that may be required should subassemblies be changed or when your operational specifications require it. Figure 5-1 illustrates the location of adjustments on Main Logic Assembly A1.

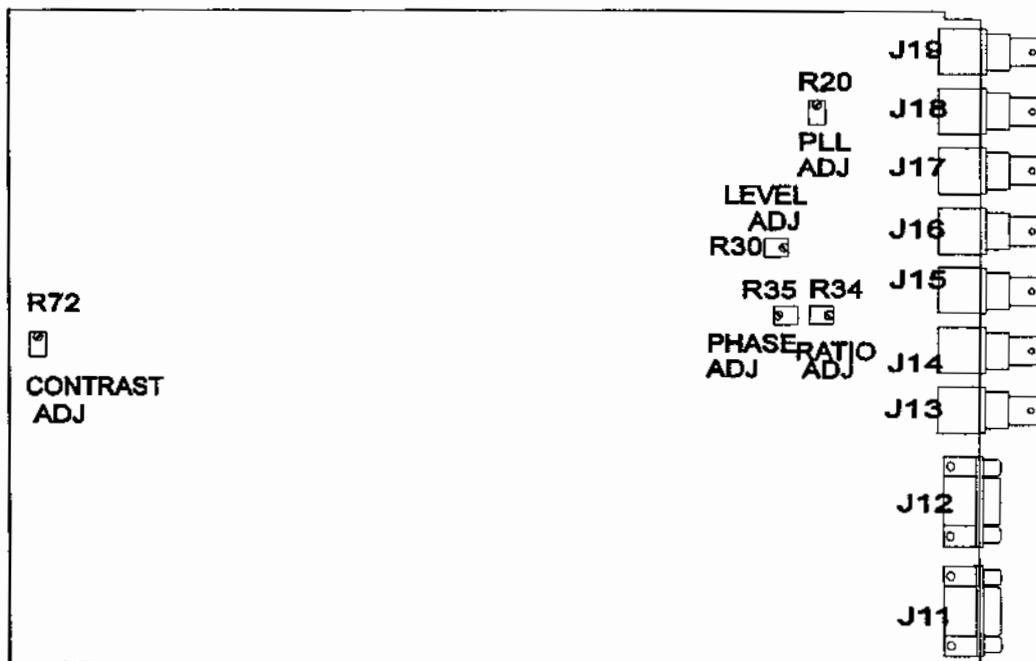

Figure 5-1. Main Logic Assembly A1 Adjustment Locations

5-3.1 Power Supply Adjustments

The Model 8820A power supplies have been adjusted at the factory and should not be readjusted in the field.

5-3.2 LCD Display Contrast Adjustment

The display CONTRAST adjustment R72 on Main Logic Assembly A1 is factory adjusted for optimum viewing but may be readjusted by the user, if desired. To readjust the display contrast, proceed as follows:

- a. Withdraw chassis from rack.
- b. Loosen eight (8) quarter-turn fasteners in top cover and remove cover.
- c. Referring to Figure 5-1, locate CONTRAST adjustment potentiometer A1R72 on forward area of Main Logic Assembly front panel.
- d. Using small screwdriver, adjust A1R72 for desired contrast. The adjustment range allows the display to become completely washed out to completely dark.
- e. Replace top cover and tighten fasteners. Reinstall instrument in rack.

5-3.3 External Standard Phase Lock Loop (PLL) Adjustment

- a. Withdraw chassis from rack.
- b. Remove top cover.
- c. Put 1 MHz into Reference Input on J19. Connect (+) lead of DVM to U41-9 and (-) lead to ground. On front panel select 1 MHz input Ext Std (Setup Screen 18).
- d. Referring to Figure 5-1, locate PLL adjustment potentiometer A1R20 and adjust for +2.2 Vdc on DVM.
- e. Disconnect DVM.
- f. Replace top cover, tighten fasteners, and reinstall instrument in rack.

5-3.4 Time Code Output Adjustments

- a. Withdraw chassis from rack.
- b. Remove top cover.
- c. Connect oscilloscope to CODE OUTPUT BNC connector J17 on rear panel.
- d. Referring to Figure 5-1, locate LEVEL adjustment potentiometer A1R30.
- e. Adjust A1R30 for desired code amplitude between 1.0 and 3.5 volts peak-to-peak.

5-3.4 Time Code Output Adjustments (cont'd)

- f. Adjust RATIO adjustment potentiometer A1R34 for desired signal output ratio between 2:1 and 6:1.
- g. Adjust PHASE adjustment potentiometer A1R35 for best zero crossings.
- h. Replace top cover and reinstall instrument in rack.

5.3.5 Oscillator Y5 Adjustments

When Status Screen 7 (Figure 3-10) displays a DAC REFERENCE of less than 500 or more than 3500, the second line of the screen displays the message, 'OSC NEEDS CAL'. This message refers to oven stabilized crystal oscillator Y5 on Main Logic Board A1 inside the 8820A. Disciplining of this oscillator is accomplished by the DAC REFERENCE voltage which, in turn, is determined by a value stored in battery-backed RAM. When the DAC REFERENCE voltage is outside prescribed limits the stored value in RAM must be reset to its default (center) value and the crystal oscillator frequency range must be centered. Perform the procedures in the following paragraphs to center the stored DAC REFERENCE value and Oscillator Y5 frequency range.

5.3.5.1 Resetting RAM-Stored DAC REFERENCE Value.

Reset the RAM-stored DAC REFERENCE value as follows;

- a. On front-panel keypad, press MENU and numbers 9 and 8 (98). The following Setup Screen is displayed:

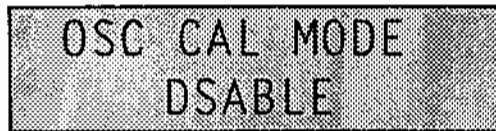

Figure 5-2. Setup Screen 98 - OSC CAL MODE

- b. On front-panel keypad, press SEL to change second line display 'DSABL' to 'ENABL'.
- c. Withdraw 8820A from rack. Loosen eight (8) quarter-turn fasteners on cover and remove cover
- d. Referring to Figure 6-1, locate Crystal Oscillator Y5 and unscrew oscillator adjustment access cover. Perform procedures A or B in following paragraphs to center oscillator frequency range

5-3.5.2 Centering Oscillator Y5 Frequency Range

The following paragraphs provide two procedures for adjusting Crystal Oscillator Y5. The first procedure uses a precision frequency source such as a tracking and locked Model 8820A and an oscilloscope. The second procedure uses a frequency counter as a reference.

A. Oscillator Adjustment Using Precision Frequency Reference

1. Using a dual channel oscilloscope, trigger channel of the oscilloscope with a precision reference frequency of 1, 5, or 10 MHz. If a tracking and locked 8820A is available, connect oscilloscope to J15 on the reference 8820A rear panel and use Setup Screen 09 on the reference 8020A to select frequency output.
2. Connect 1, 5, or 10 MPPS output from J15 of 8820A under test to channel 2 of the oscilloscope.
3. Use Setup Screen 09 to set output at J15 for 10 MPPS.
4. Adjust oscilloscope sweep speed to 100 nanoseconds per centimeter.
5. Insert a non-metallic thin-bladed screwdriver into Oscillator Y5 adjustment cavity.
6. Observe the movement of the 10 MPPS signal on oscilloscope channel 2 while slowly turning adjusting screwdriver. If the trace on channel 2 is moving to the right, turn screwdriver to the left (counterclockwise). If trace on channel 2 is moving to the left, turn adjusting screwdriver to the right (clockwise).
7. Proceeding as above, adjust oscillator for minimum movement of trace on channel 2. When properly adjusted, the 10 MPPS signal on channel 2 should move less than 100 nanoseconds in 10 seconds.
8. Remove adjusting screwdriver from oscillator adjustment cavity and replace adjustment cavity cover.
9. Referring to Figure 5-2, press SEL key again to change "ENABL" to "DSABL".
10. Disconnect oscilloscope and precision reference frequency.
11. Replace cover and tighten eight (8) quarter-turn fasteners.
12. Referring to recorded parameters entered in Table 3-4, use appropriate Setup Screens to customize the operation of your 8820A.

B. Oscillator Adjustment Using Frequency Counter Reference

1. Connect frequency counter to 1, 5, or 10 MPPS output at J15 .
2. Using Setup Screen 09, select 10 MPPS.
3. On Main Logic Assembly, unscrew Crystal Oscillator Y3 adjustment cavity cover.

B. Oscillator Adjustment Using Frequency Counter Reference (cont'd)

4. Using non-metallic thin-bladed screwdriver, adjust the oscillator for 10,000,000 \pm 1Hz.
5. Remove screwdriver from oscillator adjustment cavity and replace adjustment cavity cover.
6. Referring to Figure 5-2, press SEL key again to change 'ENABL' to 'DSABL'.
7. Remove frequency counter, replace cover, and tighten fasteners.
8. Referring to recorded parameters entered in Table 3-4, use appropriate Setup Screens to customize the operation of your 8820A.

5-4 BATTERY REPLACEMENT

The Lithium battery on Main Logic Assembly A1 powers the static RAM storing the operational parameters of the Model 8820A and the satellite information stored in the 8820A's internal GPS receiver when the instrument is unpowered. This battery has a useful life of approximately five (5) years. Prior to the end of this five-year period, the battery should be changed to avoid unexpected loss of Setup parameters, oscillator disciplining, and stored GPS Receiver satellite information.

The static RAM on Main Logic Assembly A1 and GPS Receiver Assembly A2 is powered by the instrument's power supply when external power is applied to the Model 8820A and by the internal Lithium battery when power is removed. If battery replacement is done before battery failure, power to the instrument should be left on during battery replacement. Since the instrument's internal power supply is ORED with the Lithium battery, the battery can be replaced with power applied without loss of stored operational parameters and oscillator disciplining.

When battery failure occurs with external power removed from the instrument, stored operational parameters are lost and must be reprogrammed using the Setup Screens. After powerup and satellite data must be reacquired using a 'Cold Start' procedure. In addition, at least four minutes must be allowed after satellite acquisition for the Model 8820A's internal oscillator to stabilize (the stored disciplining voltage is lost with battery failure). The following procedure assumes that battery failure occurred while external power was removed from the instrument. Perform the following procedures to replace the Lithium battery on Main Logic assembly A1:

The battery on Main Logic Assembly A1 can be replaced with any of the following batteries:

Panasonic	-	Part Number - BR2032
SANYO	-	Part Number - CR2032
Electro-Chem	-	Part Number - CR2032

With power removed from the instrument, the Model 8820A loses all stored operational data when the A1 battery is dead or removed from the instrument. It is therefore preferable to change the battery with external power applied to the instrument.

To remove and replace the battery on Main Logic Assembly A1, proceed as follows:

- a. Loosen eight (8) quarter-turn fasteners in instrument top cover and remove cover.
- b. Referring to Figure 6-1, locate battery on Main Logic Assembly A1.

5-4 BATTERY REPLACEMENT (cont'd)

- c. Remove rubber cover from battery by pulling straightup. **Note:** considerable force is required to remove rubber cover.
- d. Noting the polarity of the installed battery on Main Logic Assembly A1, gently lift the (+) battery terminal and lift the battery out of its holder. See warning below.
- e. Gently lift (+) battery terminal again and insert replacement battery with positive (+) terminal upward.
- f. Replace protective rubber cover on battery.
- g. Replace instrument top cover and tighten fasteners.
- h. Referring to recorded parameters entered in Table 3-4, use appropriate Setup Screens to customize the operation of your 8820A.
- i. If battery was changed with power removed from 8820A, use Setup Screen 19 (Figure 3-31) to enable 'Cold Start'.

WARNING

The battery removed is a fire, explosion, and severe burn hazard. Do not recharge, disassemble, heat above 212 degrees F, incinerate, or expose contents to water.

CHAPTER 6

REPLACEABLE PARTS LIST

6-1 GENERAL

Table 6-1 lists the replaceable parts in your instrument. Figure 6-1 illustrates the Model 8820A replaceable assemblies and Table 6-2 provides manufacturer's code identification.

Table 6-1. Model 8820A Replaceable Parts List

REF DES	DESCRIPTION	MFG CODE	PART NO	QTY
A1	MAIN LOGIC PC BD ASSY	11165	4004882-112	1
A2	GPS RECEIVER ASSY	11165	1001700-1	1
A3	KEYPAD PC BD ASSY	11165	3004642-101	1
A4	LCD DISPLAY ASSY	11165	3004971-101	1
A6	9 DIGIT LED DISPLAY ASSY	11165	4003811-101	1
F1	FUSE, 3A, 250V, FAST, 3AG	71400	GMA-3	1
PS1	POWER SUPPLY	11165	2005407-101	1
-	ANTENNA	11165	2006077-101	1

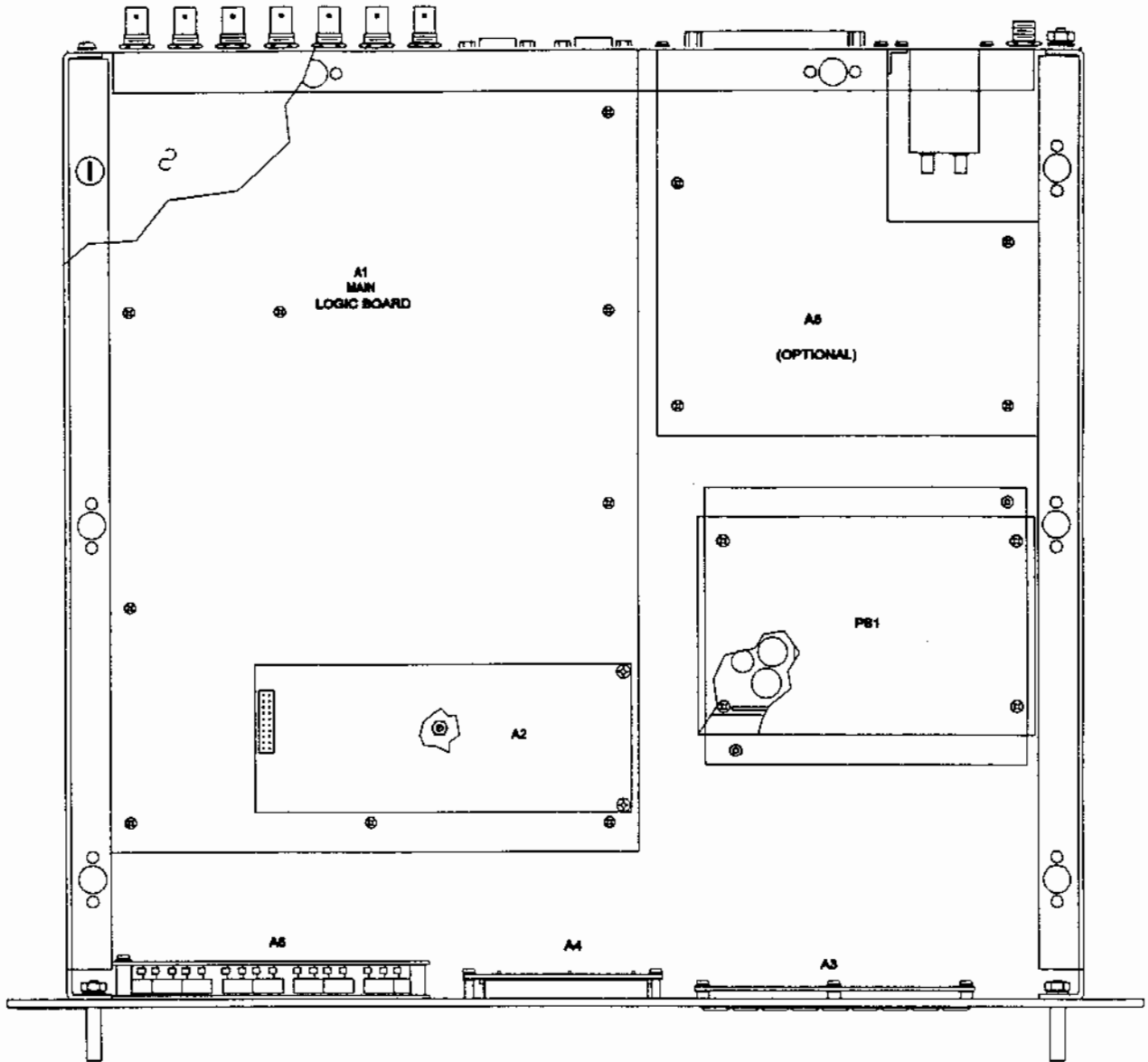

Figure 6-1. Model 8820A Major Assembly Locations

Table 6-2. Manufacturer's Code Number Identification

CODE	MANUFACTURER
00347	Schaffner EMC Inc., 825 Le High Ave., Union, N.J. 07083
11165	TRAK Systems Div. of TRAK Microwave Corp., Tampa, FL 33634
16011	Corcom, Inc., Chicago, IL 60639
71400	Bussman Div. of McGraw-Edison Co., 114 Old State Rd., St. Louis. MO 63178

APPENDIX A

GPS GLOSSARY AND ABBREVIATIONS

#	Number
AGE AG	Age (not currently supported)
AZ AZM	Azimuth
C/A CODE	Coarse Acquisition Code
CL	Class
DEG	Degrees
DOP	Dilution of precision
E	Elevation
GPS	Global Positioning System
HH	Hours
HH:MM:SS	Hours:Minutes:Seconds
HLTH	Health Code
HMS	Hundreds of milliseconds
ION, IONO	Ionosphere
L1	L-Band Frequency (1575.42 MHz)
L2	L-Band Frequency (1227.60 MHz)
LAT	Latitude
LON	Longitude
MJD	Modified Julian Day
MM	Minutes
NS	Nanoseconds
P-CODE	Precision Code
REF-GPS	Reference minus GPS (error measurement)
REF-UTC	Reference minus UTC (error measurement)
SV	Space Vehicle ID
uS	Microseconds
UT	Universal Time Coordinated (same as UTC)
UTC	Universal Time Coordinated

CLOCK PARAMETER TERMS

The following list of abbreviations is given for completeness, but rarely used by GPS timing users. (Order is same as normally printed in reports).

AODC	Age of Data, ephemeris
A2 (AF2)	Satellite Clock Polynomial Correction Term (Seconds/Seconds ²)
A1 (AF1)	Satellite Clock Polynomial Correction Term (Seconds/Second)
AO (AFO)	Satellite Clock Polynomial Correction Term (Seconds)
TGD	L1 Ionosphere's Correction Term
TOC	Check Reference Time

APPENDIX A

GPS GLOSSARY AND ABBREVIATIONS (cont'd)

DILUTION OF PRECISION TERMS

DOP	Dilution of Precision
XDOP	"X" Dilution of Precision
YDOP	"Y" Dilution of Precision
ZDOP	"Z" Dilution of Precision
TDOP	Time Dilution of Precision
GDOP	Geometric Dilution of Precision
HDOP	Height Dilution of Precision
LAD	Latitude Dilution of Precision
LOPD	Longitude Dilution of Precision
AODE	Age of the date, Ephemeris

APPENDIX B

OPTIONS

Your unit has no options.

APPENCIX C
RESERVED

APPENDIX D

GPS OVERVIEW AND POSITION MODES

The United States Government has developed a navigation system called GPS (Global Positioning System). It is a satellite-based, radio navigation aid designed to eventually provide global, all-weather, precise navigation and timing capability to users 24 hours a day.

THE GPS BUILDUP

The GPS program can be described in three phases. The first phase, started in 1978 and ended in the spring of 1989, validated the system concept. During this phase, prototype satellites (known as Block I Satellites), a ground support network, experimental user equipment, and some production user equipment were built and tested. The second phase was completed 1992. During the second phase, more coverage was added in the form of advanced Block II production satellites. The second phase began in February 1989 with the successful launch of PRN 14, the first Block II satellite. The satellite constellation at the end of this second phase, called the Optimal 21 Satellite Constellation, consisted of 18 operational satellites and three active in-orbit spares. The satellites are a mix of Block I and II satellites.

In 3-D (three-dimensional) navigation, latitude, longitude, altitude, and system time (clock) are computed using four satellites. In 2-D (two-dimensional) navigation, latitude, longitude and system time are computed using three satellites; the user enters his own altitude estimate to the navigation solution (altitude aiding).

The third phase was completed in 1993. The final constellation is composed of 24 operational satellites. Failed Block 11 satellites are replaced with Block 11R satellites as they fail. Satellite life is estimated to be 7-10 years.

GPS ORGANIZATION

The GPS system is organized in three parts: Space Segment, Control Segment, and User Segment.

The space segment is composed of the operational and in-orbit spare satellites. The GPS satellites are named NAVSTAR, which stands for Navigation System with Time and Ranging. These satellites receive signals from the control segment and transmit signals to the user segment.

The satellites transmit the following data to the users:

- " Health data
- " Ephemerides
- " Satellite constellation almanac
- " Time
- " Ranging signals
- " Atmospheric correction data

GPS ORGANIZATION (cont'd)

Space Segment

The ephemerides, as transmitted from the space segment to the user segment, describes the detailed orbital characteristics of the satellite from which it is transmitted. The satellite constellation almanac describes the coarse orbital data for all of the satellites in the constellation. This data is broadcast to the user segment where it can be stored and used for initial satellite acquisition and for satellite visibility prediction.

The health data is included in the satellite-to-user message to indicate the quality of the navigation signals. A healthy satellite provides reliable time and position update data, whereas an unhealthy satellite provides time and position update data that is suspect. This status may be displayed by the user's equipment.

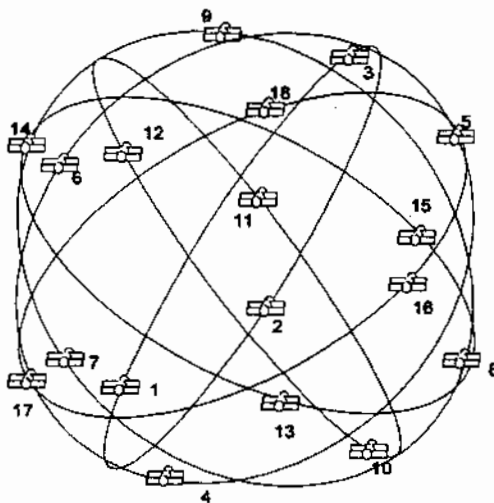

Figure 1. NAVSTAR Satellite Orbital Pattern

The NAVSTAR satellites circle the earth in the nominal 20,200 kilometer (10,900 nautical mile) orbits shown in Figure 1. The orbital geometry is six 55-degree inclined planes, with four satellite in each plane. Each satellite has an orbital period of 12 hours. The geometry of the complete constellation enables it to furnish direct line-of-sight navigation signals from at least four satellites (and usually more) to any point on or near the earth's surface almost all times.

The satellites may be identified in two different ways: Space Vehicle Number (SVN) and Pseudorandom Code Number (PRN). The SVN indicates the chronological order in which the satellites were launched into orbit. The term PRN stands for Pseudorandom Noise, which is the technique used to transmit the satellite signals. Most receiving equipment identifies satellites by their PRN.

GPS ORGANIZATION (cont'd)

Control Segment

The Control Segment monitors and tracks the NAVSTAR satellites, synchronizes their operation, performs satellite positional computations, and transmits orbital and corrected time data to the satellites. To perform these operations, the Control Segment consists of five monitor stations, one Master Control station, and three data up-load stations. The monitor stations are located in Ascension Island, Hawaii, Diego Garcia, Kwajalein, and Colorado. The Master Control Station and one data up-load station are located in Colorado. The remaining data up-load stations are located in Hawaii and Ascension Island.

The monitor stations track the satellites via their broadcast signals as the satellites rise over the horizon. The broadcast signals contain the orbital characteristics (ephemerides) of the satellites, ranging signals, clock data, and almanac data. The signals are relayed from the Monitor Stations to the Master Control Station, where the ephemerides are computed. The resulting orbital prediction data and clock (timing) corrections are then transmitted (up-loaded) to the satellites by the data up-load stations.

Since synchronization of satellite time is a critical task of the control segment, the Master Control Station is connected directly to the atomic time standard at the U.S.A Naval Observatory in Washington, DC. In this way, each satellite can broadcast an accurate description of its celestial position with respect to GPS system time. GPS system time is used as the time reference against which satellite time and user receiver time are measured.

The uncorrected difference between GPS system time and the satellites' times are called clock offsets. These time differences are corrected for seasonal and sidereal (earth time as related to star motion) drift and other time effects at the Master Control Station. The Master Control Station then broadcasts the corrected satellite time to the satellites along with the corrected ephemerides via the data up-load stations.

User Segment

The user segment consists of equipment that tracks the NAVSTAR satellites, receives the satellite signals, and uses the signals in a manner depending on the application of the user's equipment. Such applications include navigation and geodetic positioning. All of the equipment has one common fundamental application, however; it uses the signals to update its position with respect to the surface of the earth.

The satellite signals can provide positioning accuracy of a few millimeters to 100 meters, depending on the equipment design and its operational environment.

The user segment may consist of ground-based, marine, airborne, or spaceborne equipment incorporating GPS receiver/processors that can track one or more satellite signals, either simultaneously or sequentially. The tracking of at least four healthy satellites is normally required to estimate position and velocity. The receiver/processor selects satellites that provide the best geometry for an accurate position/navigation solution. As the satellites continue their orbits, the receiver/processor drops satellites with marginal geometry as satellites with better geometry become available, then tracks the revised satellite constellation.

GPS ORGANIZATION (cont'd)

Determination of user position and velocity involves taking time-of-arrival (TOA) measurements on the satellite signal, and using satellite ephemerides to calculate the position of each satellite being tracked, at the precise time of signal transmission. The TOA at the user's receiver is determined, to within the clock bias of the signal, by synchronizing user's receiver with one of the ranging codes generated by the satellite. The user's receiver/processor then calculates a pseudorange by scaling the sum of the signal propagation delays and clock bias by the speed of light. Such a range is called a pseudorange because it contains the clock errors of the user's receiver and satellite clocks. Information on the satellite clock bias contained in the satellite signal allows correction of pseudoranges by accounting for the effect of clock bias on the satellite clock.

By using three satellites and a known height, or four satellites when height is unknown, the clock bias of the user's clock can be determined.

Velocity is calculated by making Doppler measurements on the carrier frequency of the broadcast satellite signal. (Doppler is a measure of the change in frequency of the signal carrier as the signal transmitter changes in range with respect to the signal receiver.)

Navigation is usually accomplished using a Kalman filter in the receiver/- processor, which is a software navigation process stored in the receiver/processor. It produces a continuous navigation solution based on the pseudo-range and Doppler measurements.

LEVELS OF ACCURACY

The U.S.A Government grants military and other authorized users of GPS a level of navigation accuracy known as the Precise Positioning Service (PPS). Accuracy for all other users who are provided with the Standard Positioning Service (SPS), can be either better or worse than PPS, depending on three main factors.

The first factor is Selective Availability (SA), by which the U.S.A. Government has reduced accuracy for those users not granted access to the PPS. The second factor is receiver design; that is, the choice of codes, carrier frequencies, or the number of receiver channels employed. The third factor is whether differential corrections are available or not.

Figure 2 shows the four basic levels of GPS navigation accuracy performance.

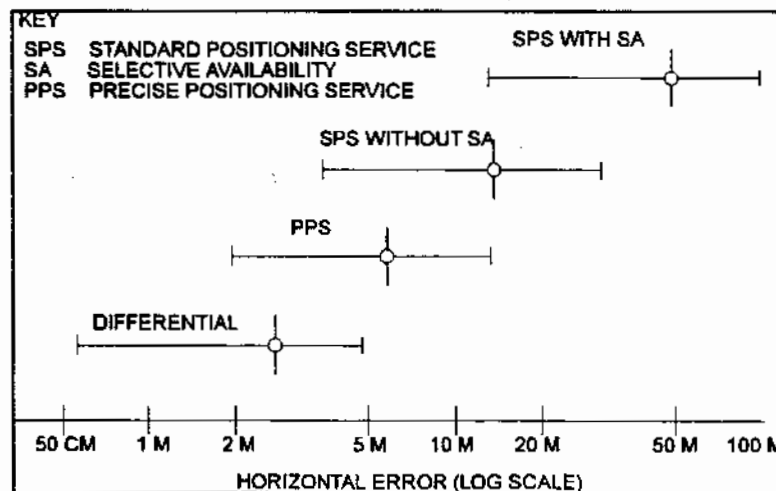

Figure 2. The Four Basic Levels of Horizontal Accuracy

LEVELS OF ACCURACY (cont'd)

At the bottom of the figure is a logarithmic scale of position error, extending from 50 centimeters at the left to 100 meters at the right. Each of the four bars begins at the 50% point and ends at the 95% point of a cumulative radial error probability curve (Rayleigh distribution), and the circle marks the CEP (Circular Error Probability), which is the 50% point. In other words, only 5% of the navigation results should be better than the left-most point, 95% should be better than the right-most point, and half should be better and half worse than the 50% point. The bar marked PPS (Precise Positioning Service) represents the accuracy potential of dual frequency P-code receivers for military users.

Just above PPS is the bar representing the SPS (Standard Positioning Service) without SA (Selective Availability). SA is the term used for the intentional accuracy reduction by the U.S.A. Government by offsetting the orbit parameters and desynchronizing the satellite clocks. SPS without SA is the accuracy currently being obtained when receivers use the Block I satellites.

Above SPS without SA is SPS with SA. This degraded accuracy occurs when Block II satellites are used.

Just below the PPS bar is the differential bar. This performance can be achieved when the user's receiver receives corrections from a differential Reference Station over a real time communications link. Note that differential accuracy is superior to PPS, although limited to a range around the Reference Station. For example, a GPS reference station at a known location on shore can provide correction signals to all vessels within hundreds of kilometers. As a result, navigation accuracy for properly equipped users in the local area can be better than 5 meters.

Sub-centimeter accuracy is achievable using the carrier phase of the satellite signals. This also is a differential process, but it employs phase measurements of the carrier wavelengths to achieve the necessary accuracy. Inherent ambiguities in the carrier phase measurements must be resolved to obtain this accuracy.

In summary, authorized military users continue to achieve the PPS accuracy of Figure B-2. Typical commercial navigation receivers now provide the accuracy shown as SPS without SA. As Selective Availability is implemented with Block II satellites, all users without access to the PPS are limited to the SPS with SA (degraded) accuracy. However, by means of a local reference receiver and communications link, users can achieve the accuracy shown as Differential, which is superior to PPS.

SPS, PPS, AND SELECTIVE AVAILABILITY

GPS provides the Standard Positioning Service (SPS) based on the C/A-code and L1 frequency (1575.42 MHz). Precise Positioning Service (PPS) is based on C/A- and P-codes, and L1 and L2 frequencies. SPS presently offers an accuracy of about 10 to 30 meters, while PPS offers an RMS accuracy of about 7 to 15 meters. The SPS is intended for civilian users, and is deliberately degraded now that the GPS system is fully operational. This degradation is called Selective Availability (SA). The PPS is intended for military users, is encrypted, and available only to authorized (primarily military) users.

GPS ERROR SOURCES

The navigational accuracy of a GPS receiver is characterized, to a first approximation, by multiplying the satellite range measurement (pseudorange) error times the Dilution of Precision (DOP) satellite geometry factor. Navigational accuracy can therefore be improved by decreasing DOP or pseudorange measurement error.

The satellite selection algorithms used by most receivers do a good job of minimizing the DOP effect. The remaining approach to improving GPS navigation is, therefore, to increase the accuracy of the pseudorange measurements.

Pseudorange errors which are common between local receivers are susceptible to differential treatment, while errors particular to an individual receiver are not. The major common error sources and their approximate sizes are:

1. Selective Availability errors: 30 m.
2. Ionospheric delays: 20-30 m by day, 3-6 m by night.
3. Tropospheric delays: up to 30 m.
4. Ephemeris errors: less than 3 m. (without SA)
5. Satellite clock errors: less than 3 m (without SA)

Selective availability (SA) errors are caused by the deliberate distortion of the GPS signals imposed by the U.S.A. Government to reduce the inherent accuracy of GPS for security reasons. With Block II satellites fully operational, SA is fully implemented and SA is the predominant error source in C/A-code navigation. Uncorrected, SA results in approximately 50 meter RMS. navigation (30 meter range error times a DOP of 1.8.)

MODEL 8820A RECEIVER DESCRIPTION

The Model 8820A contains an internal six-channel continuously tracking GPS receiver assembly.

Receiver Specifications

The detailed specifications for the internal GPS Receiver Assembly are given in Paragraph 1.1 of this manual.

Receiver Position Modes

The Model 8820A's GPS Receiver operates in the following position modes:

DYNAMIC NAVIGATE: This mode may be used at any time, but it is usually used when the receiver antenna is mounted to a moving platform (such as vehicle, vessel, or aircraft). When tracking four satellites, the Model 8820A provides accurate time and position data at platform speeds up to 1,000.00 mph. The receiver must be tracking a position data.

NOTE

The time required to obtain an initial navigation solution (position) can be significantly reduced by entering an approximate antenna position before putting platform in motion.

AUTOMATIC POSITION: This mode performs navigation solutions when four or more satellites are visible. When antenna height is known, navigate solutions are performed when tracking only three satellites. Up to six satellites can be simultaneously tracked in this mode. Once antenna position is determined, the Model 8820A outputs accurate time and frequency data and continues to do so when tracking as few as one satellite.

NOTE

When in AUTOMATIC TRACKING MODE and the number of satellites being tracked drops below three, the Model 8820A automatically switches to FIXED POSITION MODE. When three satellites are again acquired, the Model 8820A switches back to AUTOMATIC TRACKING MODE.

FIXED POSITION: This position mode is available to those users who have an accurate geodetic survey of their antenna position and wish to take advantage of the slight improvement in time accuracy that this mode provides.

This mode may also be used after an average of navigation solutions is taken over a several day period. The averaged values are manually entered as the known antenna position. The receiver tracks from one to six satellites and outputs time.

(This page intentionally blank)

APPENDIX E

GPS ANTENNA INSTALLATION AND OPTIONS (OPTIONS L9 AND UP)

This appendix provides information for the installation of the GPS antenna furnished with the TRAK Systems 8800 Series of GPS Station Clocks.

ANTENNA DESCRIPTION

The standard antenna is a quadrafilier helix volute antenna with an internal low noise preamplifier. It is environmentally sealed and suitable for exterior installation. (GPS antennas must be installed outdoors as most types of buildings attenuate the satellite signals beyond usefulness.) This antenna is provided with an antenna-to-internal 3/4 inch 14 NPT pipe thread adapter for mounting on top of a vertical mast. Figure 1 gives dimensional data and Table 1 gives the specifications. Table 2 gives the specifications for the optional in-line low-noise amplifier.

ANTENNA PLACEMENT REQUIREMENTS

It is desirable for the antenna to view as much of the sky as possible. This is accomplished by placing it above all large obstructions such as buildings, mountains, and large trees that are 10 degrees above the horizon. If it is not practical to place the antenna in a location providing close to 100% sky coverage above the 10 degree line, then place it in the best location that is available. Viewing as little as 25% of the sky allows satisfactory operation. The less sky coverage, the less tracking time that is available. A building 100 feet wide, 50 feet away from the antenna and 50 feet higher than the antenna reduces the sky coverage by about 15%; a building 10 feet away reduces the coverage by about 40%.

PERSONAL SAFETY

Do not install any antenna while there is a threat of lightning, it is raining, or the winds are over 25 MPH. When installing the antenna anywhere close to power lines, be extremely careful. All antenna masts must be grounded to a low-impedance earth ground.

ANTENNA INSTALLATION

Figures 2 through 5 present several typical installation approaches. These are provided to give you ideas to make your installation easier. Note that in all cases, the antenna is placed above the roof line. Also note that the antenna must be mounted so that it is vertical. When installations are in high wind or heavy icing areas, the mast must be large enough to withstand the elements. Use reducing couplings to change pipe size to 3/4" at the antenna.

CAUTION

Do not mount supplied antenna-to-internal 3/4-inch 14NPT pipe thread adapter to the antenna *before* threading and connecting coaxial cable to antenna. Thread coaxial cable through mast and/or tee connector. Then, thread cable through unmounted pipe thread adapter, connect cable to antenna, mount adapter to antenna with screws provided, and screw mast into pipe thread adapter. Attempting to connect coaxial cable connector to antenna after pipe thread adapter is mounted to antenna requires the use of long-nose pliers which will *damage* the cable insulation, shield, and connector.

COAX CONSIDERATIONS

The selection of the proper coaxial lead-in cable involves several factors, the primary considerations being signal attenuation, physical size, and cost.

The net required gain between the antenna and the GPS Clock input is +10 to +20 db, and the standard antenna has a gain of +35 db.

CONSIDERATIONS (Continued)

This leaves a net allowable attenuation in the cable system of 15 to 25 db. Coax cable attenuation at the GPS L1 frequency is between 1.5 and 25 db per 100 feet, depending on the coaxial cable type.

Table 3 lists signal attenuation and relative cost data for several cable types.

Note that the cost of the lower-loss cable is considerably higher than the higher-loss cable. To partially overcome this cost differential, less-expensive cable can be used in conjunction with in-line amplifiers. Power for these amplifiers passes through the center conductor of the coax cable. TRAK Systems GPS Clocks covered by this document supply current adequate to power the antenna amplifier and several in-line amplifiers. When one amplifier is used, it is placed near the middle of the cable run; when two amplifiers are used, they are placed to divide the cable run in thirds (distance between amplifiers depends on amplifier gain and cable type and is normally in the range of 150 and 300 feet). Since the net attenuation must be held between 15 and 25 db, it is necessary to match the amplifier gain to the cable loss within this range.

TRAK Systems offers cables and amplifier kits for selected lengths of 50 to 1000 feet. We also have custom cable solutions for lengths to over 5000 feet. For lengths over 1000 feet, please consult TRAK System's Application Engineering. It is best not to shorten or lengthen the cables in the TRAK supplied cable kits without signal level calculation. If cable lengths need to be altered, TRAK System's Application Engineering will be happy to assist you in choosing the optimum solution.

Table 4 lists cable options for selected lengths between 50 and 1000 feet. For lengths greater than 1000 feet, consult the factory. We have solutions for cable lengths to over 5000 feet.

Table 5 summarizes the cable losses and amplifier gains for each configuration. This table also lists the maximum number of feet of cable (see Table 4 for cable type) that may be added or subtracted.

LIGHTING PROTECTION

Because of its small physical size a properly installed antenna will not normally attract lightning. The use of lightning arrestors in the coax line does not normally protect the antenna, but may protect the GPS Engine located in the GPS Clock.

If a lightning arrestor is installed, locate it in the lead-in cable as close as possible to the cable entrance to the building.

HIGH POWER ENVIRONMENT

An extensive study conducted by a large power company with many sub-stations has shown that a GPS antenna should be placed at least 10 meters from any power line with a voltage exceeding 10 kv. Often, at a substation, an existing tower raising 10 meters or more above the power lines can be used. It is also important to shield the coax from the fields of high voltage lines. If your buildings are metal and the antenna is placed on the side of the building just above the roof line, the coax should enter the building with a minimum of exposed coax. If it is not possible to enter the building with less than 2 meters of coax length, it is recommended to place the coax in a steel conduit with the conduit grounded to the building. If metal buildings are not used, then it is even more important to provide grounded conduit to shield the antenna lead.

Do not run the coax in parallel with power circuits without using a grounded steel conduit. This includes runs within buildings where the coax runs parallel to power lines carrying over 250 volts.

**Table 1
Antenna Electrical Specifications**

ANTENNA:	
Type	Quadrafilier helix
Frequency	1575.42 MHz
Polarization	RHCP
Gain	-2.0 dBc @ ±80°
Coverage	Hemispherical
PREAMPLIFIER:	
Gain	35 dB min
Noise Figure	< 2.0 dB
Bandwidth (-3dB)	30 MHz
Bandwidth(-20dB)	100 MHz
DC voltage input	+5 to 15 VDC
DC Current	< 65 Milliamps
Connector	TNC
PHYSICAL	
Size (envelope)	4.25" Dia x 6.4" High
Weight	7 ounces
Mounting	3/4 - 14 NPT pipe thread adapter for vertical pipe mast.
Temperature	-40 to +70° C.

**Table 2
In-line Amplifier Specifications**

ELECTRICAL:	
Gain	15, 20, 25 & 30 dB typ
Noise Figure	<3.5 dB
Bandwidth	(-3dB)15 MHz
DC Voltage	+5 to 15 VDC
DC Current	<35 milliamps
PHYSICAL:	
Size	1.5" x 1.125" x 3.625"
Finish	Nickel plated
Weight	<4 ounces
Mounting *	2 Tapped holes
Temperature	-40 to + 70° C.

* Normally, the cable can support the in-line amplifier.

Table 3. Coax Cable Selection

TYPE	DIAMETER (inches)	ATTENUATION (db/100 FT)	RELATIVE COST *** (ratio)
RG-58/U	.146	24	-
RG-213/U	.405	11.8 *	1
Cooper/Belden #9913	.405	6.5	1
Andrew #LDF2-50	.44	4.5	4
Andrew #LDF4-50A	.63	3.0	5
Andrew #LDF5-50A	1.09	1.7 **	12

* Specific for Carol #C1176 version of RG-213/U

** Even lower loss cables are available.

*** Relative cost is only a guide, as cable costs have many variables.

Table 4. Antenna/Coax Options

OPTION	LEAD-IN LENGTH	DESCRIPTION
L9	None	The GPS Antenna with no cable provided.
L10	50 ft	L9 antenna and a 50 foot length of RG-58 coax cable (This option is included in the basic GPS Clock price).
L11	100 ft	L9 antenna and a 100 foot length of RG-213 coax cable.
L22	250 ft	L9 antenna and a 250 foot length of Cooper/Belden #9913 coax cable.
L23	500 ft	L9 antenna, two 250 foot lengths of Cooper/Belden #9913 coax cable and one 15 db gain in-line amplifier.
L24	750 ft	L9 antenna, two 375 foot lengths of Cooper/Belden #9913 coax cable and one 30 db gain in-line amplifiers.
L25	1000 ft	L9 antenna, two 350 foot lengths, one 300 foot length of Cooper/Belden #9913 coax cable, and two 25 db gain in-line amplifiers.
L26-xxxx	100-2500 ft	L9 antenna, cable lengths and in-line amplifiers selected for optimum operation for the required length. (Contact TRAK Systems' application engineering for additional information.
L27-xxx	300-500 ft	L9 antenna and a single length of Andrew #LDF2-50 cable cut to specified length (xxx) without the need for an in-line amplifier. A 10 foot length of Cooper/ Belden #9913 cable is provided to make a flexible interface to the unit.
L28-xxx	500-800 ft	L9 antenna and a single length of Andrew #LDF4-50A cable cut to specified length (xxx) without the need for an in-line amplifier. A 10 foot length of Cooper/ Belden #9913 cable is provided to make a flexible interface to the unit.
L29-xxx	800-1400 ft	L9 antenna and a single length of Andrew #LDF2-5 cable cut to specified length (xxx) without the need for an in-line amplifier. A 10 foot length of Cooper/ Belden #9913 cable is provided to make a flexible interface to the unit.

Coax cable options L27, L28 & L29 are for applications where in-line amplifiers are not desired. The cost of using Andrew cable will normally be higher than using a lower cost cable with in-line amplifiers. Also, the Andrew cable is very rigid and requires special handling.

Table 5. In-line Amplifier Options

AMP-15	In-line amplifier with 15 db gain.
AMP-20	In-line amplifier with 20 db gain.
AMP-25	In-line amplifier with 25 db gain.
AMP-30	In-line amplifier with 30 db gain.

Table 6. Cable Loss Chart

The following table is based on the use of an antenna with 35 db net gain.

OPTION	CABLE LENGTH (feet)	CABLE LOSS* (db)	AMP GAIN (db)	NET GAIN (db)	MAX ADD (feet)	MAX DELETE (feet)
L10	50	15		20	25	none
L11	100	14		21	70	none
L22	250	19		16	50	50
L23	500	35	15	15	50	50
L24	750	52	30	13	40	60
L25	1000	69	2 X 25	16	50	50

* Includes 3 db loss through the interface to the receiver.

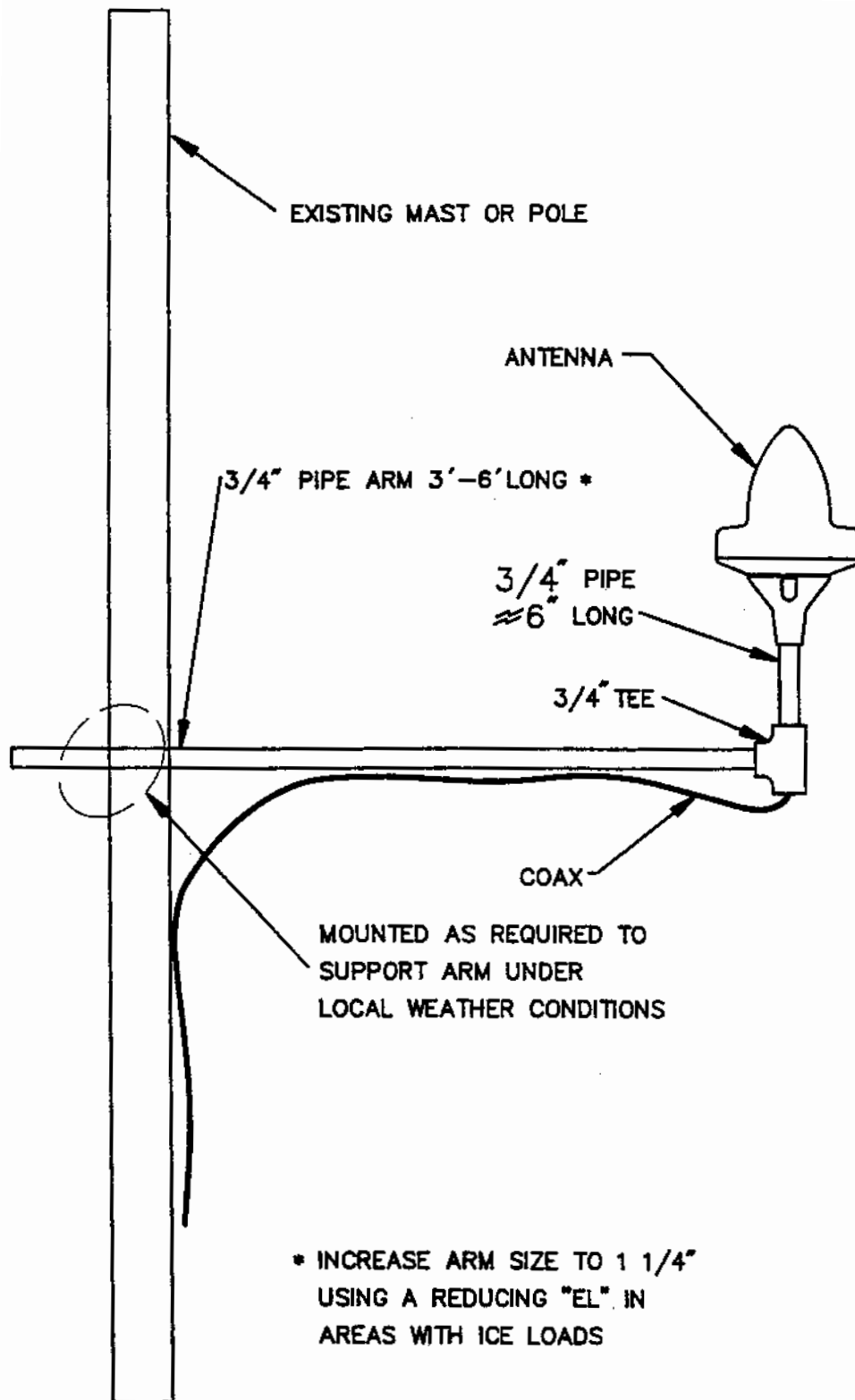

FIGURE 2
MOUNTING TO EXISTING MAST

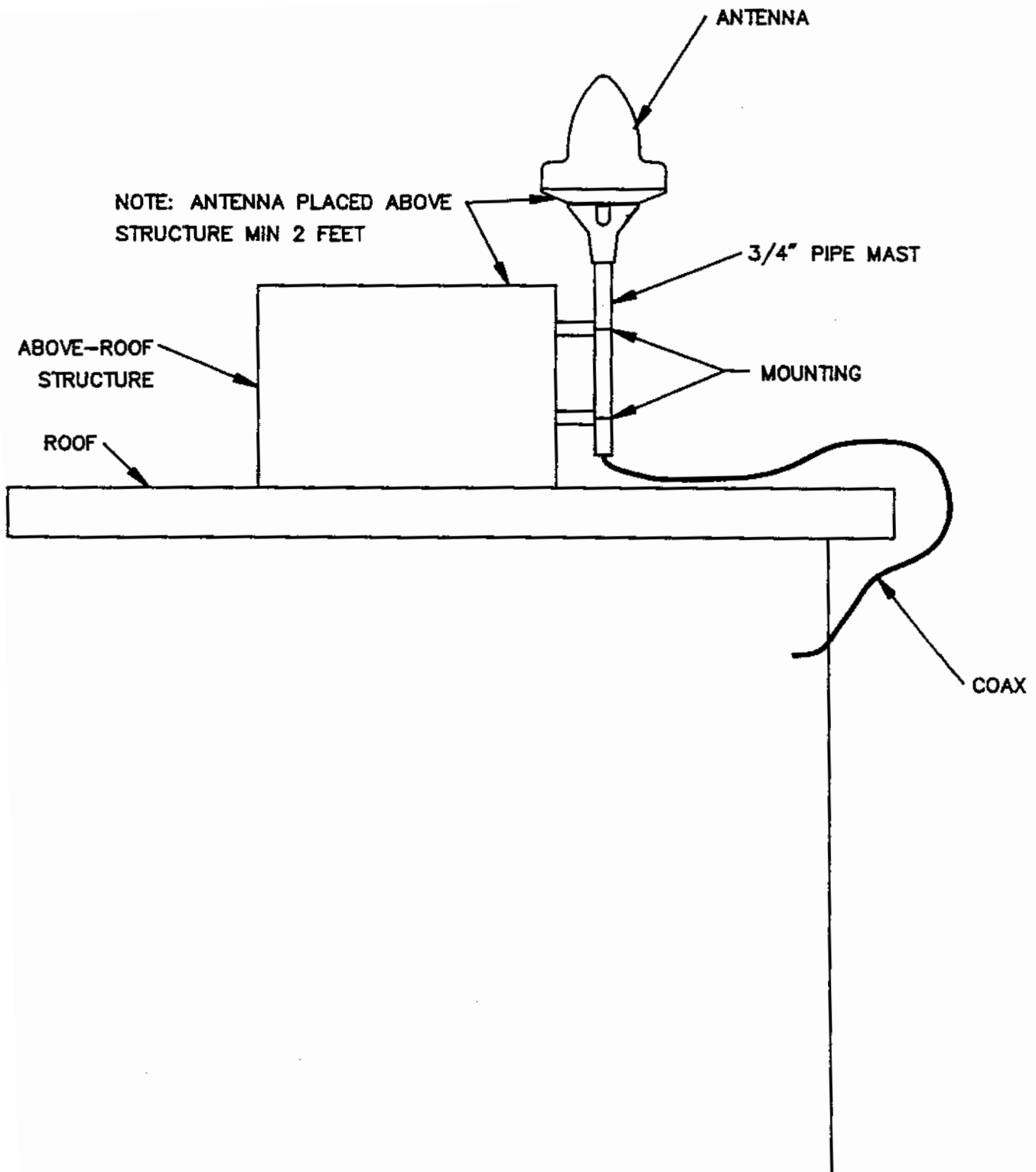

FIGURE 3
MOUNTING TO EXISTING ROOF STRUCTURE

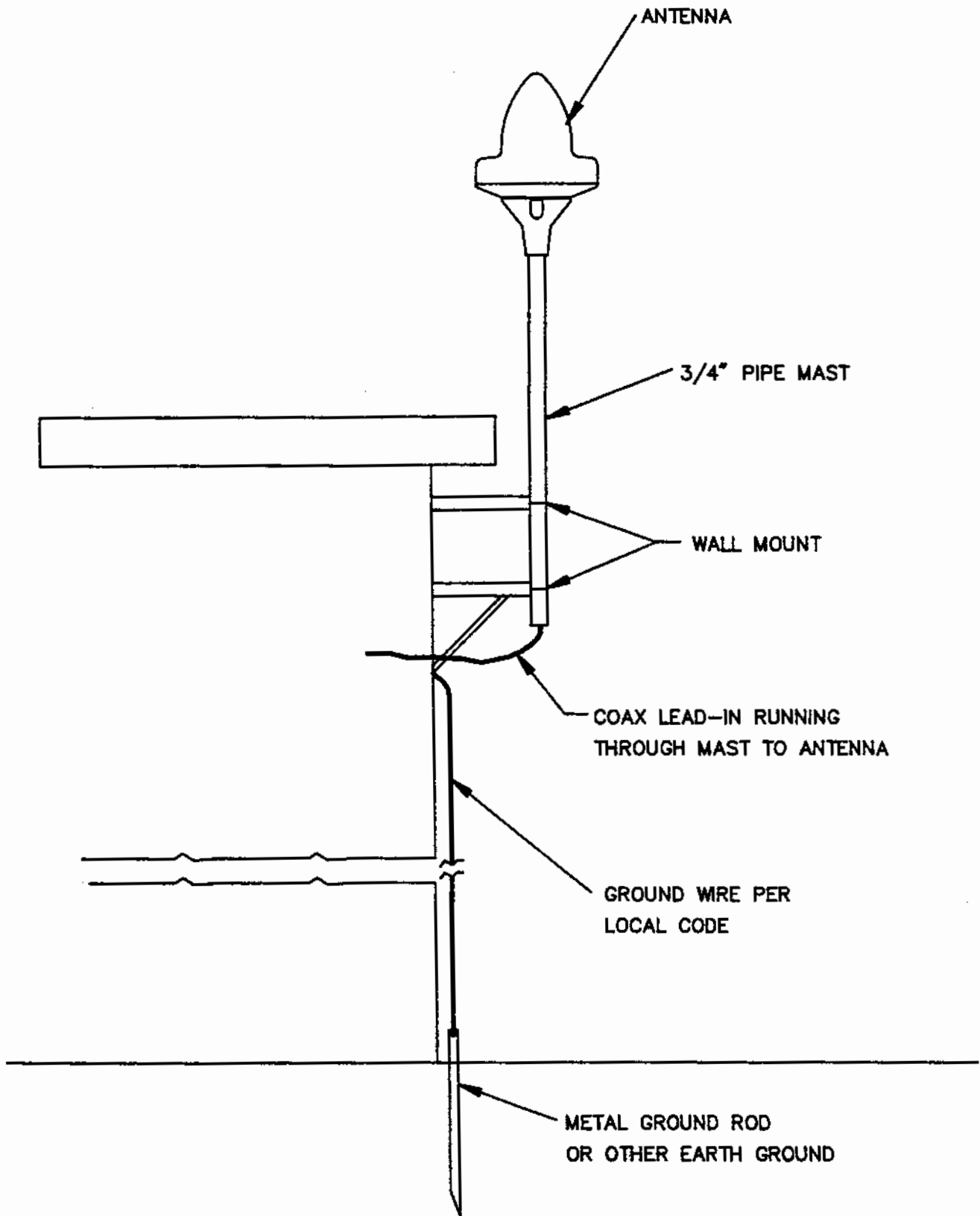

FIGURE 4
MOUNTING TO SIDE OF A TALL BUILDING

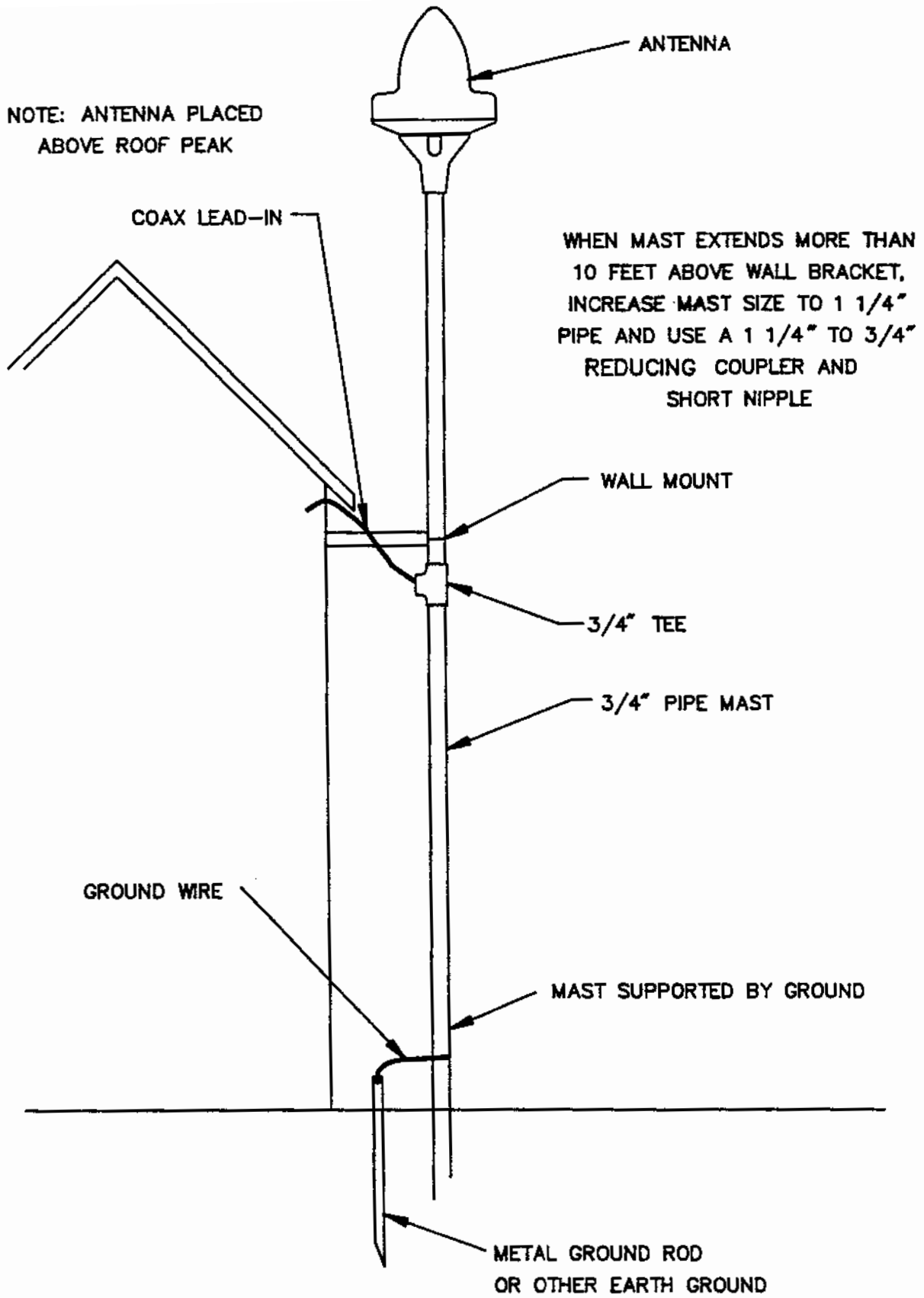

FIGURE 5
MOUNTING WITH GROUND AND BUILDING SUPPORT

APPENDIX F

TIME CODE FORMATS

INTRODUCTION: The commonly used time code formats are shown in this appendix. The IRIG B and NASA 36-Bit one-second time codes are most commonly used for general purpose time distribution and magnetic tape annotation applications requiring time of year data. The XR3 and 2137 codes are commonly used for magnetic tape annotation where day of year data are not required.

IRIG A: Ten frames per second. BCD coding 0.1 seconds through hundreds of days. Binary seconds of the day optional. Modulated code uses 10 KHz carrier.

IRIG B: One frame per second. BCD coding units-seconds through hundreds of days. Binary seconds of the day optional. Modulated code uses 1 KHz carrier.

IRIG E: Ten second time frame. BCD coding tens of seconds through hundreds of days. Modulated code normally uses 100 Hz or 1 KHz carrier.

IRIG G: One-hundred frames per second. BCD coding tens of milliseconds through hundreds of days. Highest speed standard serial code. Modulated code uses 100 KHz carrier.

NASA 36-Bit: One frame per second. BCD coding unit seconds through hundreds of days. Modulated code uses 1 KHz carrier.

XR3: One frame per second. BCD coding unit-seconds through tens of hours (days data not encoded). Ideal for tape recording and playback uses. Modulated code has 250 Hz carrier.

2137: Same as XR3 except that carrier frequency is 1 KHz.

IRIG H: One frame per minute. BCD coding units-minutes through hundreds of days. Normally used in DC level shift form for strip chart recording. Modulated code normally uses 100 Hz or 1 KHz carrier.

IRIG A CODE FORMAT

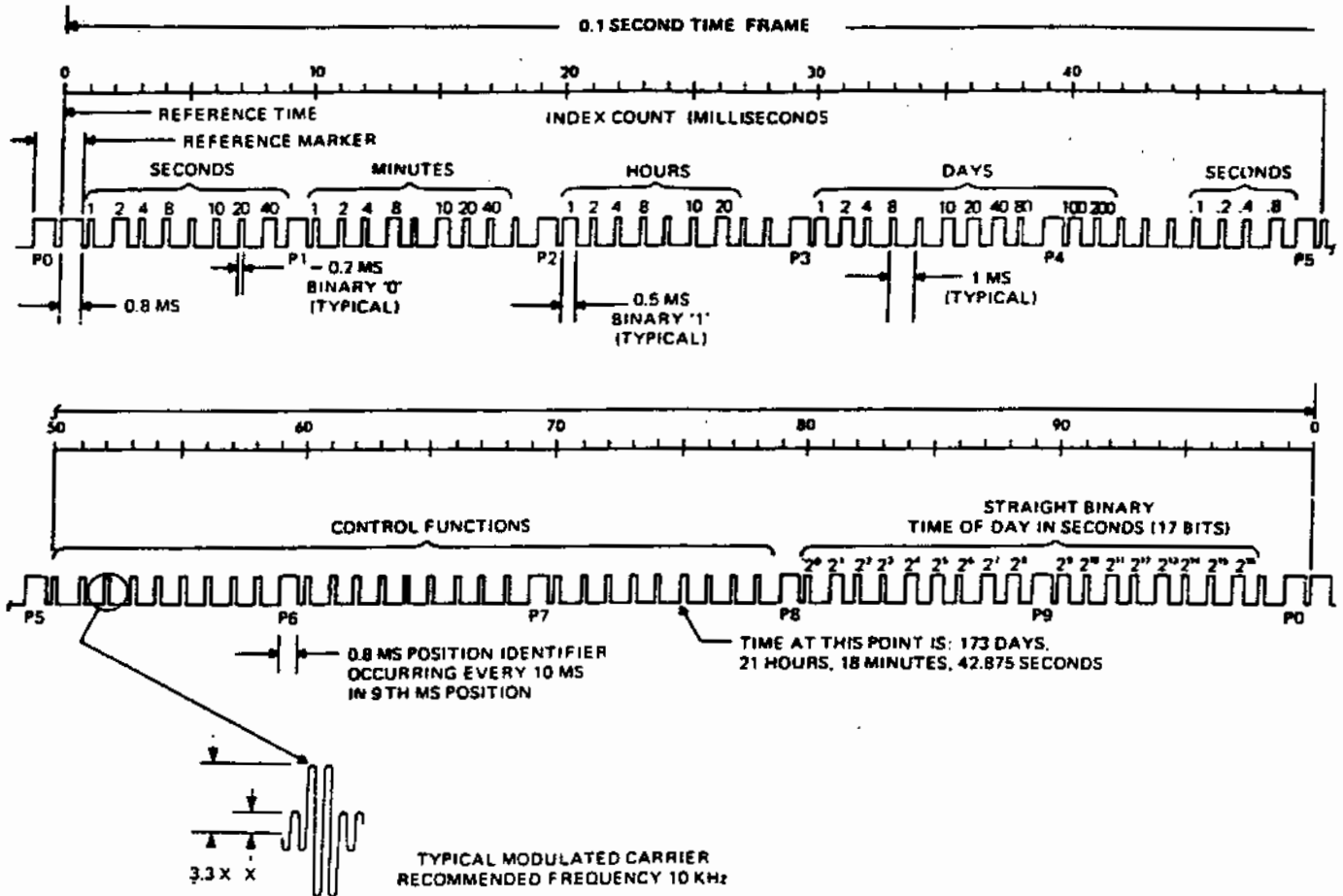

The IRIG A time code has a tenth-second (100 ms) time frame and contains BCD time information representing tenths-of-seconds, seconds, minutes, hours, days, and straight-binary-time-of-day (SBTOD) in seconds. Provisions are made in the code for control functions. An 0.8 millisecond frame reference marker appears during the first millisecond of each frame, and 0.8 millisecond position identifiers appear during the 9th millisecond of each 10 ms period.

The BCD time data appear in the first five 10 ms time periods of each tenth-second frame, control functions (when used) appear in the next three 10 ms time periods, and the SBTOD data appear in the last two 10 ms time periods. Binary ZEROs and fill bits are 0.2 ms long, and binary ONEs are 0.5 ms long. Modifications to the code include deletion of days data, deletion of SBTOD data, and deletion of both of these data groups.

IRIG B CODE FORMAT

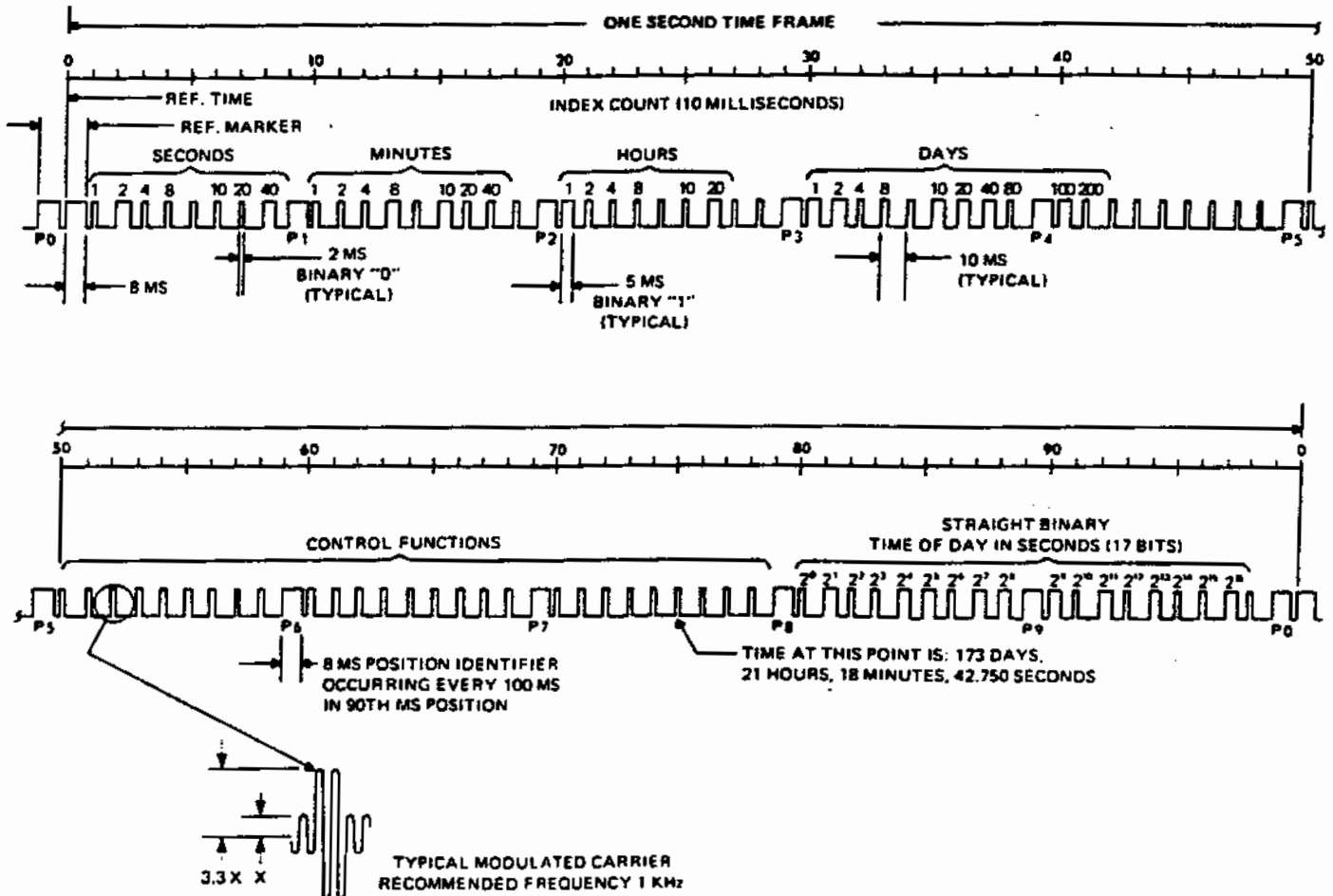

The IRIG B time code has a one-second time frame and contains BCD time information representing seconds, minutes, hours, days, and straight-binary-time-of-day (SBTOD) in seconds. Provisions are made in the format for control functions. An 8-millisecond frame reference marker appears during the first 10 ms of each frame, and 8-millisecond position identifiers appear during the 90th millisecond of each 100 millisecond period. The BCD time data appear in the

first five 100 millisecond time periods of each one-second frame, control functions (when used) appear in the next three 100 millisecond time periods, and the SBTOD data appear in the last two 100 ms time periods. Binary ZEROs and fill bits are 2 ms long, and Binary ONES are 5 ms long. Modifications to the code include deletion of the days data, deletion of the SBTOD data, and deletion of both of these data groups.

IRIG E CODE FORMAT

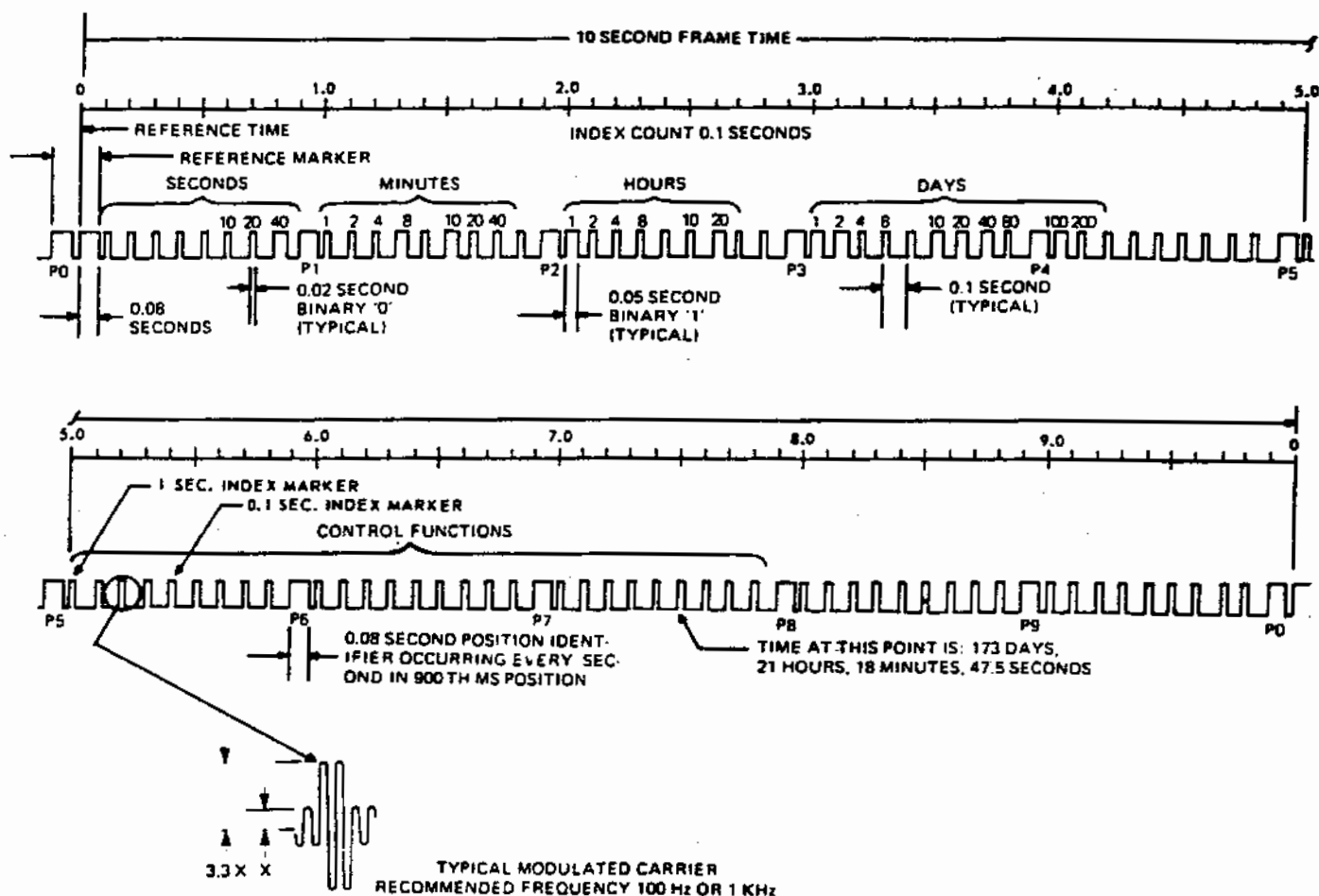

The IRIG E time code has a ten-second time frame and contains BCD time information representing tens-of-seconds, minutes, hours, and days. Provisions are made in the format for control functions. An 0.08 second (80 ms) frame reference marker appears during the first 100 milliseconds of each frame, and .08 second (80 ms) position identifiers appear during the

900th millisecond of each one-second period. The BCD time data appear in the first five one-second periods of each ten-second frame and control functions (when used) appear in the next three one-second time periods. Binary ZEROs and fill bits are 0.02 seconds (20 ms) long, and binary ONES are 0.05 seconds (50 ms) long.

IRIG G CODE FORMAT

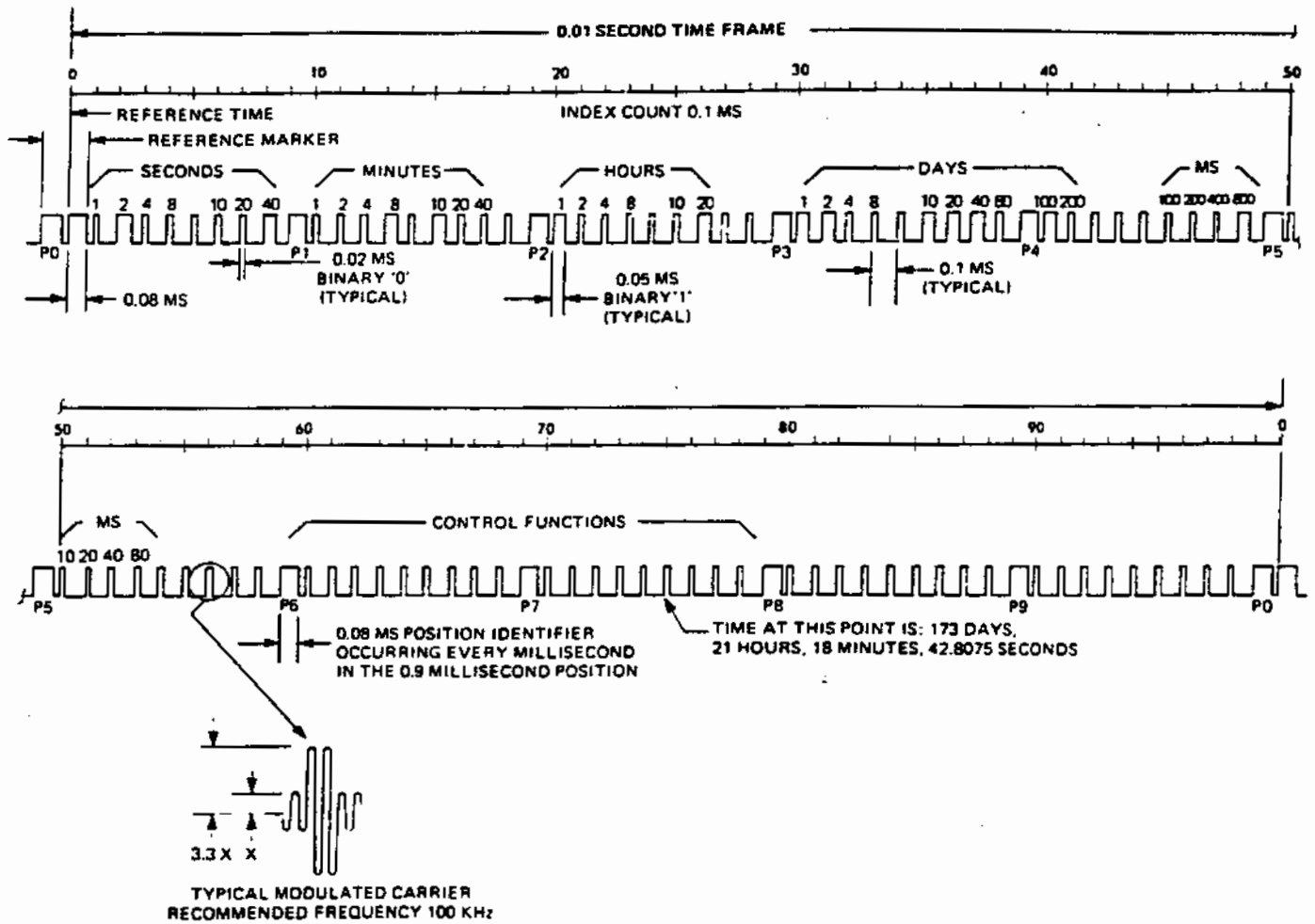

The IRIG G time code has an 0.01 second time frame and contains BCD time information representing 0.01 seconds, 0.1 seconds, seconds, minutes, hours, and days. Provisions are made in the format for control functions. An 0.08-ms (80 μ sec) frame reference marker appears during the first tenth-millisecond of each frame, and 0.08-ms (80 μ sec) position identifiers ap-

pear during the last tenth-millisecond of each one-millisecond period. The BCD time data appear in the first six one-millisecond time periods, and the control functions (when used) appear in the next two one-millisecond time periods. Binary ZEROs and fill bits are 0.02 ms (20 μ sec) long and binary ONES are 0.05 ms (50 μ sec) long.

IRIG H CODE FORMAT

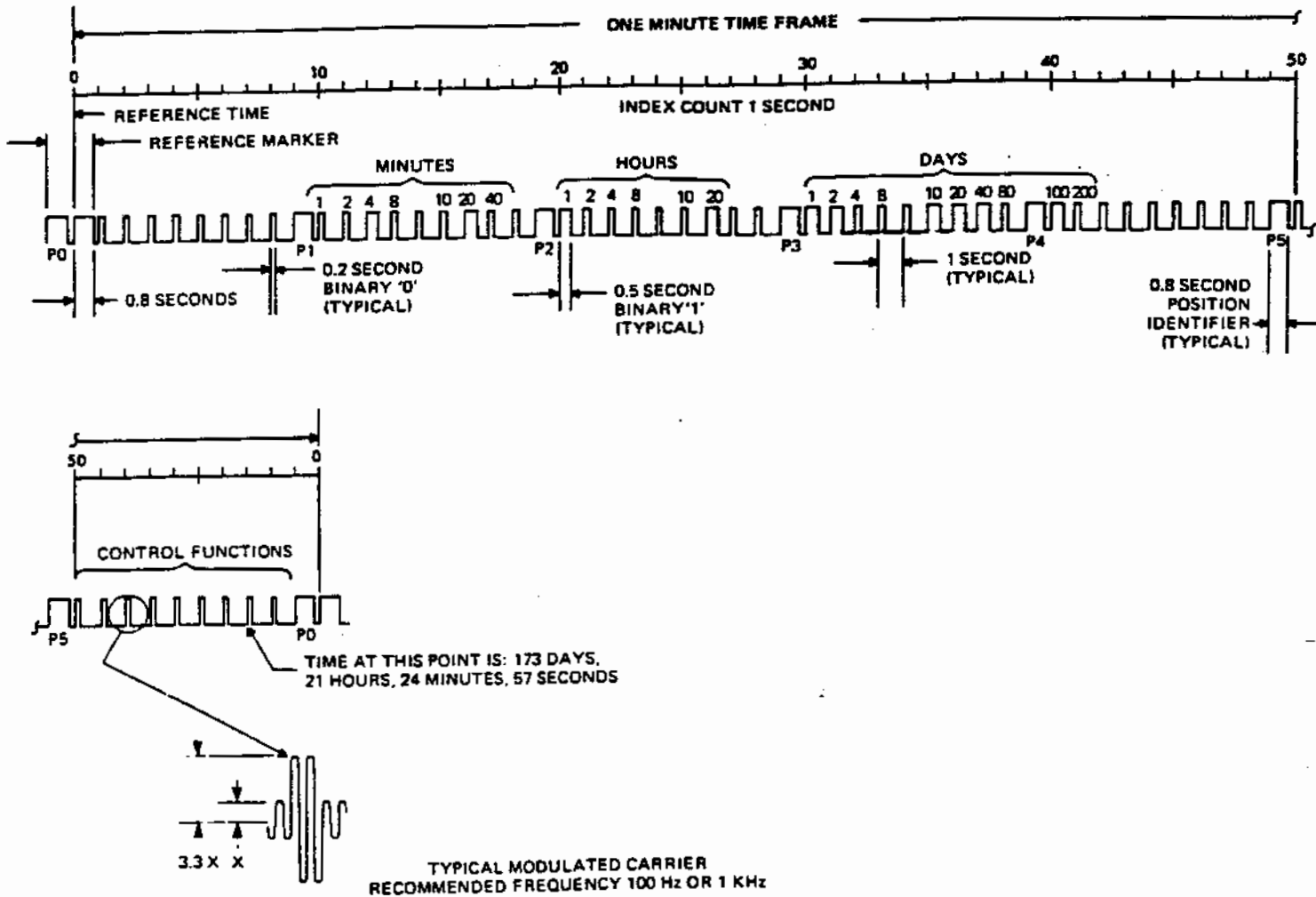

The IRIG H time code has a one-minute time frame and contains BCD time information representing minutes, hours, and days. Provisions are made in the code format for control functions. An 0.8-second (800-ms) position identifier appears during the ninth second of each ten-second period. The BCD time data appear

in the second through fifth ten-second periods, and control functions (when used) appear during the sixth ten-second period. Binary ZEROs and fill bits are 0.2 seconds (200 milliseconds) long and binary ONES are 0.5 seconds (500 milliseconds) long. IRIG H replaces IRIG C as the standard one-minute format.

NASA 36-BIT CODE FORMAT

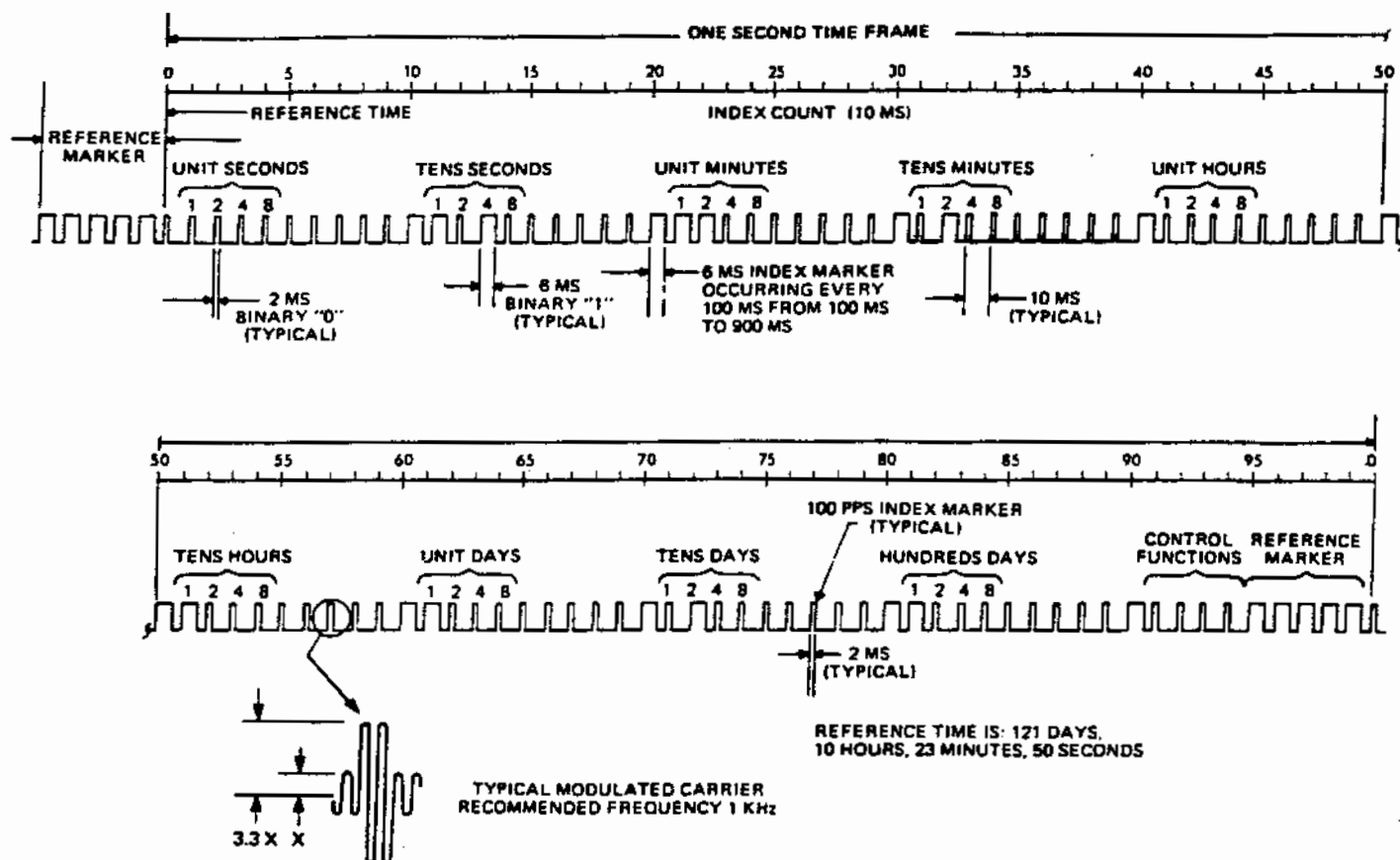

The NASA 36-Bit code has a one-second time frame. BCD time information representing days, hours, minutes, and seconds is encoded in each frame. Four control function bits may also be encoded. Binary ZEROs are two milliseconds wide and binary ONES are five milliseconds wide. The frame reference marker comprises five ONES followed by a ZERO at the beginning of the next frame. Position identifiers

(binary ONES) appear during the first ten milliseconds of each 100-millisecond period (except at 00 time). The four BCD bits representing each time digit appear LSB-first during the forty milliseconds after the frame reference marker and position identifiers, with the four control function bits appearing after the last position identifier (at 900 milliseconds).

XR3/2137 CODE FORMAT

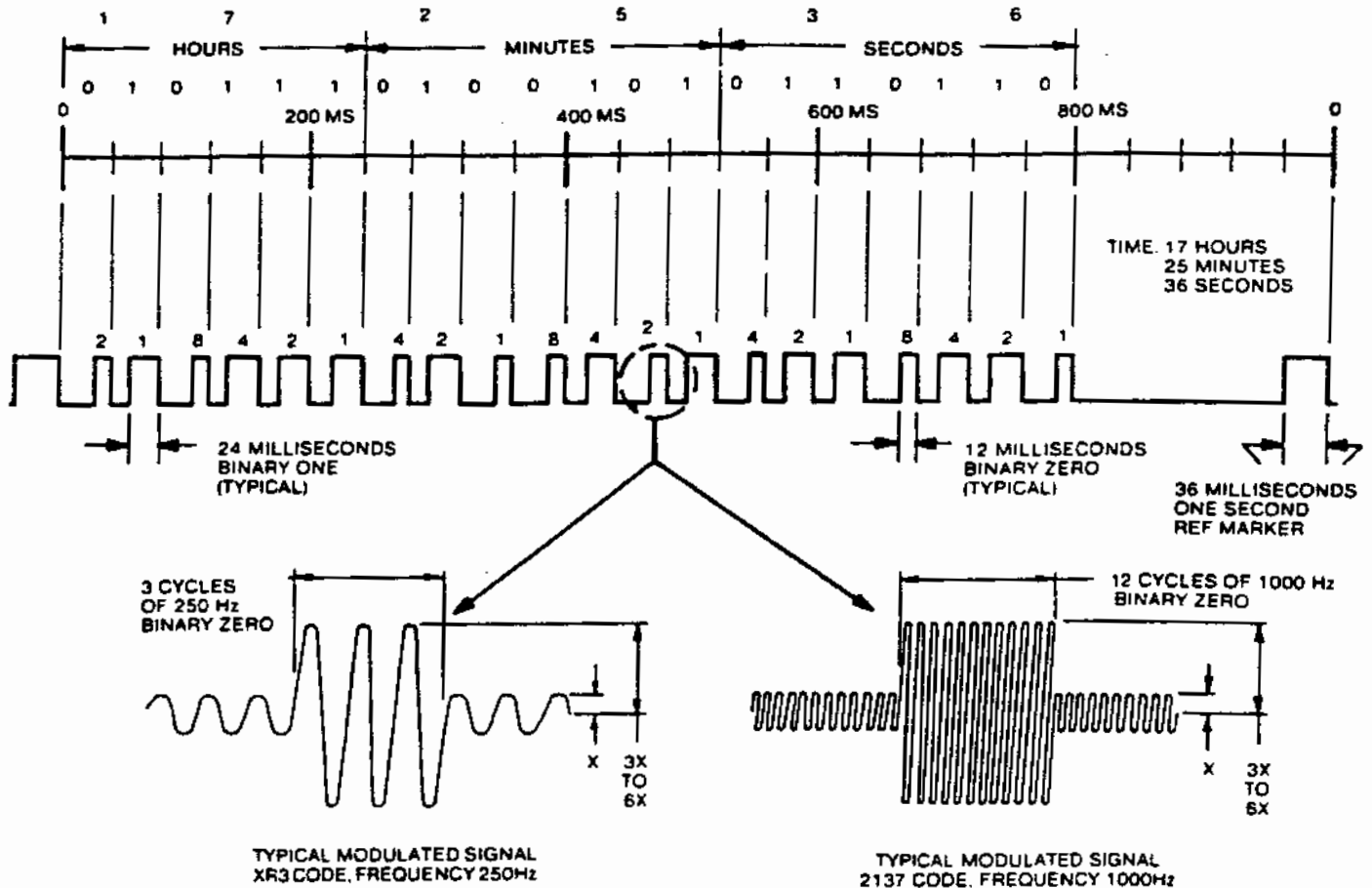

The XR3/2137 time code has a one-second time frame. The code contains BCD time information representing hours, minutes, and seconds. Each frame has 20 time bits, a gap with a length equal to four bit-periods, and a frame reference marker. Each bit-period is 40-ms long. A binary ZERO is 12 ms wide, a binary ONE is 24 ms wide, and the reference marker is 36 ms wide. All of these bits are placed at the end of their respective bit-periods. The

XR3 code has a 250 Hz carrier: binary ZEROs have seven normal cycles followed by three boosted cycles, binary ONEs have four normal cycles followed by six boosted cycles, and the reference marker has one normal cycle followed by nine boosted cycles. The 2137 code has a 1000 Hz carrier: binary ZEROs, binary ONEs, and reference markers have their last 12, 24, and 36 cycles, respectively, boosted.

REV	DESCRIPTION	DATE
1	PRELIM. RELEASE	
2	J30 WAS J26.R232 WAS TO MHz	

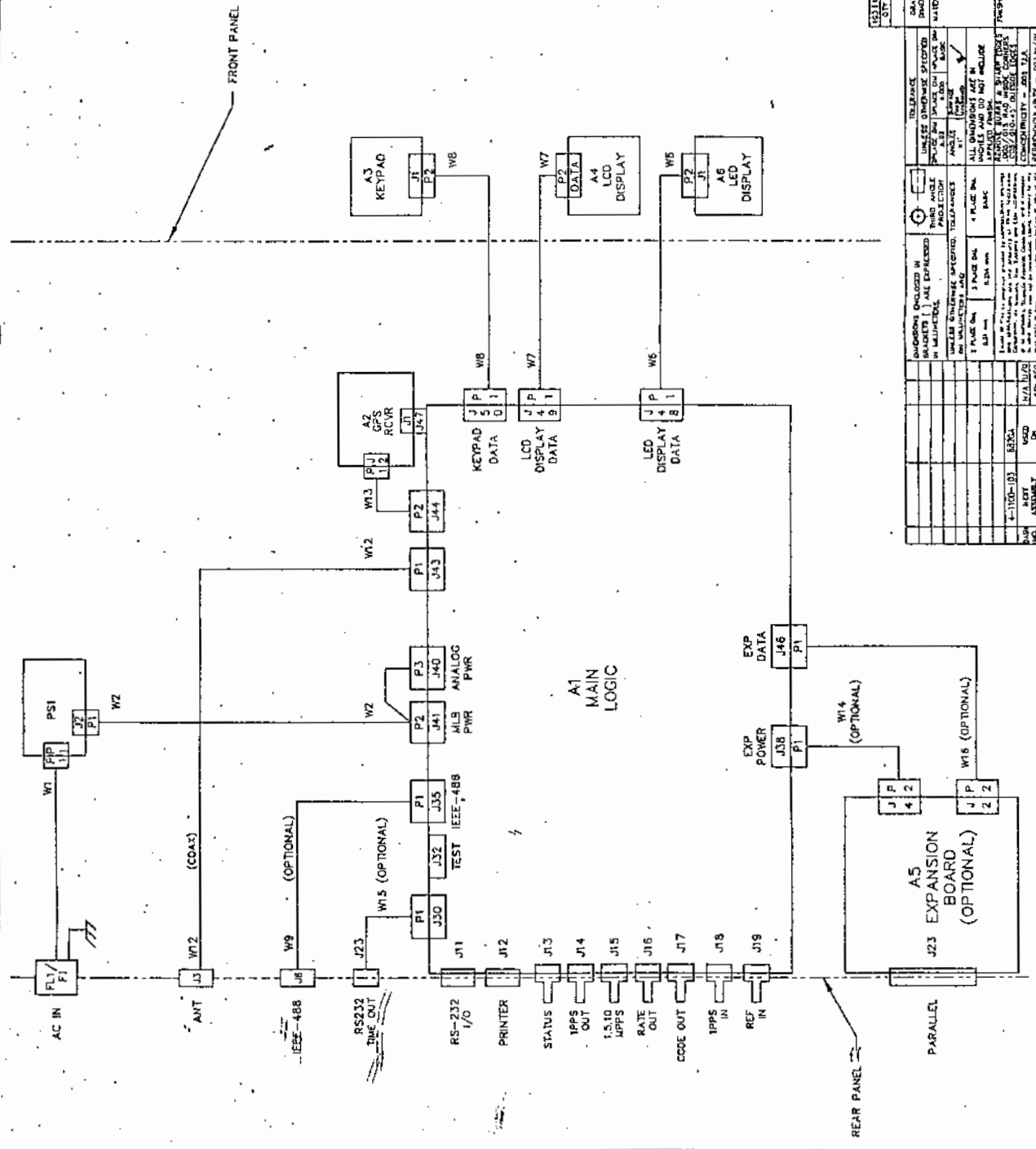

REV	DESCRIPTION	DATE
1	PRELIM. RELEASE	
2	J30 WAS J26.R232 WAS TO MHz	

REV	DESCRIPTION	DATE
1	PRELIM. RELEASE	
2	J30 WAS J26.R232 WAS TO MHz	

REV	DESCRIPTION	DATE
1	PRELIM. RELEASE	
2	J30 WAS J26.R232 WAS TO MHz	

REV	DESCRIPTION	DATE
1	PRELIM. RELEASE	
2	J30 WAS J26.R232 WAS TO MHz	

REV	DESCRIPTION	DATE
1	PRELIM. RELEASE	
2	J30 WAS J26.R232 WAS TO MHz	

REV	DESCRIPTION	DATE
1	PRELIM. RELEASE	
2	J30 WAS J26.R232 WAS TO MHz	