



**MODEL 8195**  
**GPS AGELESS™ OSCILLATOR**  
**INSTRUCTION MANUAL**

SPECTRACOM CORPORATION  
101 DESPATCH DRIVE  
EAST ROCHESTER, NY 14445-1484

PHONE 716-381-4827  
FAX 716-381-4998

REVISIONS, IF ANY, ARE LOCATED AT THE END OF THE MANUAL

MANUAL REVISION 1.5  
SOFTWARE VERSION 1.04  
FEBRUARY 1998

# TABLE OF CONTENTS

## **SECTION 1      GENERAL INFORMATION**

<b>1.0</b>	<b>INTRODUCTION</b> .....	<b>1-1</b>
<b>1.1</b>	<b>FEATURES</b> .....	<b>1-2</b>
<b>1.2</b>	<b>WARRANTY INFORMATION AND PRODUCT SUPPORT</b> .....	<b>1-2</b>
<b>1.3</b>	<b>MANUAL ERRATA AND SPECIAL DOCUMENTATION</b> .....	<b>1-2</b>
<b>1.4</b>	<b>UNPACKING</b> .....	<b>1-3</b>
<b>1.5</b>	<b>SPECIFICATIONS</b> .....	<b>1-3</b>
1.5.1	Receiver .....	1-4
1.5.2	Standard Frequency Outputs .....	1-4
1.5.3	Frequency Standard Stability .....	1-5
1.5.4	1 PPS Output.....	1-6
1.5.5	1544 kHz Timing Outputs.....	1-6
1.5.6	Data Clock Timing Outputs .....	1-7
1.5.7	Indicator Lamps .....	1-7
1.5.8	Alarms.....	1-8
1.5.9	Communication Ports .....	1-10
1.5.10	Input Power .....	1-11
1.5.11	Mechanical .....	1-11
1.5.12	Environmental.....	1-11
1.5.13	Product Information .....	1-12
1.5.14	Model 8225 GPS Antenna Specifications .....	1-12

## **SECTION 2      INSTALLATION**

<b>2.0</b>	<b>INTRODUCTION</b> .....	<b>2-1</b>
<b>2.1</b>	<b>MODEL 8225 GPS ANTENNA</b> .....	<b>2-1</b>
2.1.1	Antenna Installation .....	2-1
2.1.2	Antenna Cable .....	2-2
<b>2.2</b>	<b>MODEL 8195 PREPARATION FOR USE</b> .....	<b>2-3</b>
2.2.1	AC Power .....	2-3
2.2.2	DC Power .....	2-3
2.2.3	Antenna Connection .....	2-3
2.2.4	Chassis Ground.....	2-4
<b>2.3</b>	<b>INITIAL OPERATION</b> .....	<b>2-4</b>
<b>2.4</b>	<b>FACTORY CONFIGURATION</b> .....	<b>2-5</b>

## **SECTION 3      OPERATION**

<b>3.0</b>	<b>INTRODUCTION</b> .....	<b>3-1</b>
<b>3.1</b>	<b>ALARM DESCRIPTION</b> .....	<b>3-1</b>
	3.1.1 Major Alarm .....	3-2
	3.1.2 Minor Alarm .....	3-2
<b>3.2</b>	<b>FRONT PANEL FUNCTIONS</b> .....	<b>3-3</b>
	3.2.1 Status Lamps .....	3-3
	3.2.2. Alarm Lamps .....	3-3
	3.2.3 Battery Lamps (Option 02 only) .....	3-5
	3.2.4 RS-232 Com .....	3-5
	3.2.5 10-MHz Output .....	3-6
	3.2.6 1PPS Output .....	3-7
<b>3.3</b>	<b>REAR PANEL FUNCTIONS</b> .....	<b>3-7</b>
	3.3.1 GPS Antenna .....	3-7
	3.3.2 Frequency Outputs .....	3-7
	3.3.3 1544 kHz Timing Output .....	3-11
	3.3.4 Data Clock Timing Outputs .....	3-13
	3.3.5 Set Up Switches .....	3-15
	3.3.6 RS-485 COM .....	3-16
	3.3.7 Alarm Outputs .....	3-17
	3.3.8 DC Power .....	3-18
	3.3.9 AC Input .....	3-19
	3.3.10 Chassis Ground .....	3-20

## **SECTION 4      SOFTWARE COMMANDS**

<b>4.0</b>	<b>INTRODUCTION</b> .....	<b>4-1</b>
<b>4.1</b>	<b>RS-232 COMMANDS</b> .....	<b>4-1</b>
<b>4.2</b>	<b>RS-485 COMMANDS</b> .....	<b>4-18</b>

**SECTION 5      OPTIONS AND ACCESSORIES**

<b>5.0</b>	<b>INTRODUCTION</b> .....	<b>5-1</b>
<b>5.1</b>	<b>OPTION 02 INTERNAL BATTERY BACKUP</b> .....	<b>5-1</b>
	5.1.1 Battery Lamps .....	5-2
	5.1.2 Option 02 Specifications.....	5-2
<b>5.2</b>	<b>OPTION 03 BUILT IN DISTRIBUTION AMPLIFIER</b> .....	<b>5-3</b>
	5.2.1 System Components .....	5-3
<b>5.3</b>	<b>OPTION 07 - 5-MHZ OUTPUTS</b> .....	<b>5-8</b>
<b>5.4</b>	<b>OPTION 08 - 1-MHZ OUTPUTS</b> .....	<b>5-8</b>
<b>5.5</b>	<b>OPTION 11 - RACK MOUNT SLIDES</b> .....	<b>5-9</b>
<b>5.6</b>	<b>OPTION 31 10-HZ CHANNEL OFFSET</b> .....	<b>5-10</b>
<b>5.7</b>	<b>OPTION 52 12-24 VOLT DC INPUT</b> .....	<b>5-11</b>
	5.7.1 Option 52 Specifications.....	5-11
<b>5.8</b>	<b>ANTENNA ACCESSORIES</b> .....	<b>5-12</b>
	5.8.1 Model 8226 Impulse Suppressor .....	5-12
	5.8.2 Model 8227 Inline GPS Amplifier .....	5-13
	5.8.3 Model 8213 Antenna Mount .....	5-13
	5.8.4 Antenna Coax.....	5-14

# TABLES AND ILLUSTRATIONS

TABLE 1-1	MODEL 8195 ANCILLARY KITS .....	1-3
TABLE 2-1	DEFAULT SETTINGS.....	2-5
TABLE 3-1	RS-232 COMM PIN ASSIGNMENTS .....	3-6
TABLE 3-2	UHF SIMULCAST OFFSETS .....	3-9
TABLE 3-3	VHF HI SIMULCAST OFFSETS .....	3-10
TABLE 3-4	1544 KHZ PIN ASSIGNMENTS.....	3-11
TABLE 3-5	DATA CLOCK PIN ASSIGNMENTS.....	3-13
TABLE 3-6	ADDRESS SELECTION .....	3-15
TABLE 3-7	RS-485 COM PIN ASSIGNMENTS .....	3-16
TABLE 3-8	ALARM OPERATION .....	3-18
TABLE 4-1	ALPHABETICAL LIST OF RS-232 COMMANDS.....	4-2
TABLE 4-2	RS-485 COMMAND PROTOCOL .....	4-18
TABLE 4-3	ALPHABETICAL LIST OF RS-485 COMMANDS.....	4-19
TABLE 5-1	LINE TAP LOADS.....	5-6
TABLE 5-2	OPTION 11 CHECKLIST .....	5-9
TABLE 5-3	TV OFFSETS .....	5-11
FIGURE 1-1	MODEL 8195 AGELESS OSCILLATOR.....	1-1
FIGURE 2-1	ANTENNA INSTALLATION.....	2-2
FIGURE 2-2	DC POWER CONNECTOR .....	2-4
FIGURE 3-1	MODEL 8195 FRONT PANEL .....	3-4
FIGURE 3-2	RS-232 COM PIN NUMBERING.....	3-6
FIGURE 3-3	MODEL 8195 REAR PANEL.....	3-8
FIGURE 3-4	1544-KHZ CONNECTOR.....	3-11
FIGURE 3-5	RS-485 OUTPUT.....	3-12
FIGURE 3-6	SINGLE-ENDED CONNECTION .....	3-12
FIGURE 3-7	DATA CLOCK CONNECTOR .....	3-13
FIGURE 3-8	RS-485 LINE DRIVER.....	3-14
FIGURE 3-9	COM CONNECTOR.....	3-16
FIGURE 3-10	RS-485 CONNECTION .....	3-17
FIGURE 3-11	ALARM OUTPUTS TERMINAL BLOCK .....	3-17
FIGURE 3-12	DC POWER CONNECTOR .....	3-19
FIGURE 3-13	AC POWER MODULE.....	3-20
FIGURE 4-1	COMMAND STRUCTURE .....	4-1
FIGURE 5-1	LINE TAP NUMBER AND DISTANCE CHART - OPTION 03 .....	5-7
FIGURE 5-2	TYPICAL INTERCONNECTION DIAGRAM .....	5-8
FIGURE 5-3	SLIDES, OPTION 11 .....	5-10
FIGURE 5-4	MODEL 8226 IMPULSE SUPPRESSOR.....	5-12
FIGURE 5-5	MODEL 8227 INLINE AMPLIFIER .....	5-13
FIGURE 5-6	CABLE GUIDELINES .....	5-13
FIGURE 5-7	MODEL 8213 ANTENNA MOUNT .....	5-14

# GENERAL INFORMATION

## 1.0 INTRODUCTION

The patented Spectracom Model 8195 Ageless™ Oscillator\*, shown in Figure 1-1, is an oven-stabilized highly accurate frequency source. Its outputs are locked to the United States Naval Observatory via the NAVSTAR Global Positioning System (GPS). Spectracom's field-proven Ageless™ Oscillator technology provides continual automatic frequency control. A long-term averaging algorithm compensates for oscillator aging and temperature drift.

The Model 8195 is ideally suited as a site master oscillator for communication systems. Typical transmitter applications include land mobile simulcast, SMR (Specialized Mobile Radio), paging simulcast, satellite/microwave communications links, cellular telephone, and broadcast television.

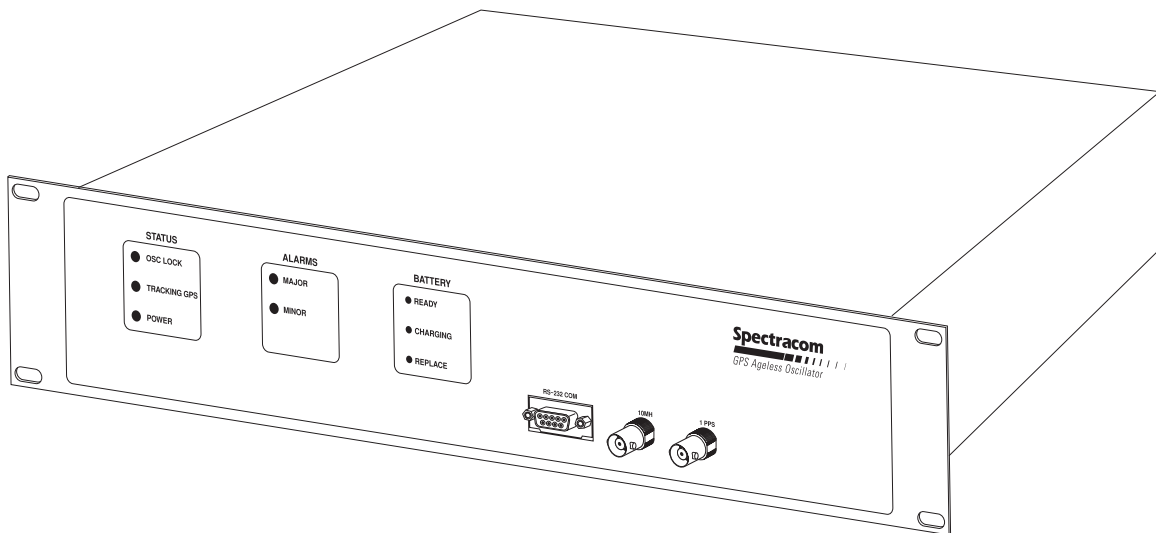

**FIGURE 1-1 MODEL 8195 AGELESS OSCILLATOR**

---

\* PATENT NO. 4,525,685

## **1.1 FEATURES**

- Better than  $1 \times 10^{-10}$  frequency accuracy, controlled by GPS
- Multiple Outputs: Five @ 10 MHz; two @ 1PPS, 1 each @ 1544 kHz, 9600 Hz and 300 Hz
- Additional Output Options: 5 MHz; 1 MHz; 33.33 Hz; and Internal Distribution Amplifier
- AC or DC power configurations
- Internal Battery Backup available
- RS-232 and RS-485 communications ports
- Precise Frequency offsets for VHF-Hi simulcast and Broadcast TV

## **1.2 WARRANTY INFORMATION AND PRODUCT SUPPORT**

Warranty information is found on the leading pages of this manual. Should it become necessary to exercise the warranty, contact Spectracom Corporation to obtain a replacement or service.

Spectracom continuously strives to improve its products and therefore greatly appreciates any and all customer feedback given. Please direct any comments or questions regarding application, operation, or service to Spectracom's Customer Service Department. Customer Service is available Monday through Friday from 8:00 A. M. to 4:00 P. M. Eastern time at 716-381-4827.

In addition, please contact customer service to obtain a Return Material Authorization Number (RMA#) before returning any instrument to Spectracom Corporation. Please provide the serial number and failure symptoms.

Transportation to the factory is to be prepaid by the customer.

## **1.3 MANUAL ERRATA AND SPECIAL DOCUMENTATION**

Information concerning manual corrections or changes made to the instrument occurring after printing are found in the Errata section located at the rear of this manual.

Spectracom will make instrument modifications upon special request. The documentation associated with any special is also located in the back of the manual.

**1.4 UNPACKING**

Upon receipt, carefully examine the carton and its contents. If there is damage to the carton which results in damage to the unit, contact the carrier immediately so its representative may witness such damage. Failing to report shipping damage immediately may forfeit any claim against the carrier. In addition, notify Spectracom Corporation of shipping damage to obtain a replacement or repair services.

Carefully open the shipping carton and remove the packing list from the envelope on the outside of the carton. Check the packing list against the contents to be sure all items have been received, including an instruction manual and ancillary kit. Table 1-1 lists the items included in the various Model 8195 ancillary kits.

<b>MODEL 8195 ANCILLARY KITS</b>				
<b>Description</b>	<b>Part Number</b>	<b>STD</b>	<b>Option 03 Distribution</b>	<b>Option 52 DC Power</b>
Fuse, 1.5A Slo-Blo	F011R5	2	2	0
Fuse, 2.0A Slo-Blo	F012R0	0	0	1
Terminal Block, 13-position	P13113	1	1	1
Terminal Block, 6-position	P13006	1	1	1
Line Cord	W01000	1	1	0
Terminator, DC-isolated	004490	0	4	0

**TABLE 1-1 MODEL 8195 ANCILLARY KITS**

## **1.5 SPECIFICATIONS**

This section contains specifications for the standard Model 8195 GPS Ageless Oscillator and Model 8225 GPS Antenna. Specifications pertaining to Model 8195 options and accessory items are found in Section 5.

### **1.5.1 Receiver**

Received Standard:	L1 C/A Code transmitted at 1575.45 MHz.
Satellites Tracked:	Up to 8 simultaneously
Acquisition Time:	Typically <20 minutes during initial installation; typically <1 minute thereafter.
Acquisition Sensitivity:	-105 dBm to -137 dBm
Tracking Sensitivity:	-139 dBm
Timing Accuracy:	<130 nanoseconds with Selective Availability "SA" on.  <50 nanoseconds with SA on in Position Hold mode.

### **1.5.2 Standard Frequency Outputs**

Signal:	10-MHz sinewave derived from GPS disciplined oscillator
Connector:	BNC female, one front panel, four rear panel
Signal Level:	600 mV rms into 50 ohms
Source Impedance:	50 ohms
Harmonics:	better than 30 dB down
Spurious:	better than 40 dB down.
Signature Control:	The four rear panel Frequency Outputs can be configured with Signature Control. Under Signature Control, the outputs are removed whenever a Major Alarm is asserted. The outputs are restored when the fault condition is corrected. The Signature Control feature is set via the RS-232 communication port.
Simulcast Offsets:	The disciplined oscillator output can be offset in precise steps to minimize co-channel interference.

The offsets provide steps of  $\pm 3, 5, 7, 9$  Hz at VHF-HI frequencies, and  $\pm 1, 2, 3, 4$  Hz at UHF frequencies. Offsets are selected by software commands.

**Output Options:**

The following options are available for various Model 8195 applications:

Option 03 Distribution Amplifier: Allows the Model 8195 to drive Spectracom distribution products. This option adds a 12 Volt DC offset to the rear panel Frequency Outputs.

Option 07: Changes the rear panel Frequency Outputs to 5.0 MHz.

Option 08: Changes the rear panel Frequency Outputs to 1.0 MHz.

Option 31: 10 Hz TV channel offsets provide additional  $\pm 10$  Hz offset when translated to the visual carrier frequency.

**1.5.3 Frequency Standard Stability**

**Long Term:**

Accuracy is typically better than  $\pm 1 \times 10^{-10}$  when locked to GPS.

**Short Term:**

$2 \times 10^{-10}$  rms over 10 successive 10-second counts.

**Load:**

$\pm 1.0 \times 10^{-10}$  for any load change.

**Supply Voltage:**

$\pm 2.5 \times 10^{-10}$  max. for  $\pm 15\%$  voltage change.

**Recovery:**

During a power failure, the oscillator control value is retained and the connected standby supply provides power to the oscillator and GPS receiver. At power-on, the disciplined oscillator returns to the set frequency plus any incurred aging.

**Aging Rate:**

$\pm 2 \times 10^{-9}$ /week typical at constant temperature after 180 days of continuous operation.  $\pm 5 \times 10^{-10}$ /24 hours at constant temperature maximum after 180 days of continuous operation. Unit automatically corrects for oscillator aging when locked to GPS.

## ***Section 1: General Information***

---

### **1.5.4 1 PPS Output**

Signal:	One pulse-per-second square wave derived from the GPS receiver.
Connector:	BNC female, front panel
Signal Level:	TTL-compatible into loads >100 ohms
Pulse Width:	200 milliseconds
Accuracy:	Positive edge within $\pm 130$ nanoseconds of UTC when tracking GPS and NO DELAY selected.
Delay Control:	The 1PPS output can be delayed 0 - 1 second in 0.1 microsecond steps. The delay value is entered via the RS-232 or RS-485 communication port.

### **1.5.5 1544 kHz Timing Outputs**

Signal:	1544 kHz, derived from the GPS disciplined 10 MHz oscillator
Connector:	RJ-11, rear panel
Signal Level:	RS-485
Duty Cycle:	50% $\pm$ 2%
Accuracy:	$\pm 1.0 \times 10^{-10}$
Additional Outputs:	Alarm Tracking Timeout 1 (AT1) relay contacts; C, NO, NC are provided on this connector.

**1.5.6 Data Clock Timing Outputs**

Signal:	1PPS, 9.6 kHz, 300 Hz, derived from the GPS disciplined 10 MHz oscillator, leading edge synchronized to the GPS 1PPS.
Connector:	DB9 female, rear panel
Signal Level:	RS-485
Duty Cycle:	1PPS: 20% $\pm$ 5% 9.6 kHz, 300 Hz: 50% $\pm$ 2%
Accuracy:	1PPS: Within 1 microsecond of UTC when tracking GPS and NO DELAY selected. The 1PPS output can be delayed 0-1 second in 0.1 microsecond steps. The delay value is entered via the RS-232 or RS-485 communication port.  9.6 kHz, 300 Hz: Leading edge synchronized to the GPS 1PPS within 1.0 microsecond.
Additional Outputs:	Alarm Tracking Timeouts AT1 and AT2 status are provided.
Optional Outputs:	The 300 Hz output is configurable to 33.33 Hz via the RS-232 communication port. Pulse width is 208 microseconds.

**1.5.7 Indicator Lamps**

Front panel LEDs when lit indicate the following:

Power:	Primary power source is connected and switched ON.
Tracking GPS:	Receiver is locked to at least one GPS satellite.
Oscillator Locked:	Oscillator is disciplined to the received GPS signal.
Major Alarm:	Alarm condition classified as “major” is active.
Minor Alarm:	Alarm condition classified as “minor” is active.
Optional Indicators:	Receivers equipped with Option 2, Internal Battery Backup, include indicator lamps to communicate battery status: Ready, Charging, and Replace.

## ***Section 1: General Information***

---

### **1.5.8 Alarms**

Alarm relays allow remote monitoring of operational status. Relay contacts are provided for Major Alarms, Minor Alarms, and Alarm Tracking Timeouts. Alarm status is also included in performance and status logs obtained using software commands.

#### **1.5.8.1 Alarm Classifications**

**Major Alarm:** A Major alarm is asserted when detected faults compromise output accuracy. The alarm relays reset when the fault condition is corrected. Faults and conditions listed below actuate a Major Alarm:

Frequency Error Alarm: Measured oscillator frequency error exceeds  $1 \times 10^{-8}$ .

GPS Tracking Timeout 2: The period of time (AT2) allotted for operation without tracking a satellite has expired.

GPS Tracking Timeout 3: The period of time (AT3) allotted for operation without tracking a satellite has expired.

CPU Fault: The CPU is unable to communicate with the GPS receiver.

Test Mode: Unit has been placed in TEST MODE operation.

Free Run: The automatic frequency control feature has been disabled.

Short Gate: Gate time is configured for 10 seconds, measurement resolution is reduced.

**Minor Alarm:** A minor alarm is asserted when failures detected do not immediately affect output accuracy. The alarm relays reset when the fault condition is corrected. Faults and conditions listed below actuate a Minor Alarm:

Output Fault: An output from any of the four Frequency Outputs connectors is not detected. Fault could be caused by a shorted cable, reflections due to an unterminated cable or removed by a Major Alarm when Signature Control is enabled.

Oscillator Adjust: Warns that oscillator is operating within 10% of the minimum or maximum control setting. The oscillator requires manual adjustment.

GPS Tracking Timeout 1: The period of time (AT1) allotted for operation without tracking a satellite has expired.

Replace Battery: Internal battery pack, Option 02 only, has failed daily test, needs replacement.

Frequency Offset: A new simulcast or TV offset (Option 31) value is entered. The alarm remains active until the standard oscillator has corrected for the offset.

Test Mode: Unit is placed in Test Mode operation from RS-232 communication port.

#### *1.5.8.2 Tracking Alarm Classifications*

The three Alarm Tracking Timeouts **AT1**, **AT2**, and **AT3** are configured via the RS-232 and RS-485 communication ports.

**AT1** (Alarm-Tracking Timeout 1): Length of time the unit has not received at least one satellite. Factory default is one (1) minute. Range is one (1) second to 999 days. This is a Minor Alarm which also extinguishes front panel TRACKING GPS lamp.

**AT2** (Alarm-Tracking Timeout 2): Length of time the unit has not received at least one satellite. Factory default is 2 hours 30 minutes. Range is one (1) second to 999 days. This is a Major Alarm which also extinguishes the OSC LOCK lamp.

**AT3** (Alarm-Timeout 3): Length of time the unit has not received at least one satellite. Factory default is thirty (30) days. Range is one (1) second to 999 days. This is a Major Alarm.

#### *1.5.8.3 Alarm Interface*

Alarm contacts are provided on the Alarm Outputs, 1544 kHz timing output, and Data Clock connectors.

<b>Alarm Outputs:</b>	Major, Minor, AT1, AT2, AT3
Connector:	13-position terminal block, rear panel
Contacts:	The NO, NC, and Common relay contacts for Major and Minor alarms. NC and Common for AT1, AT2, and AT3.
Contact Rating:	30 VDC, 2 amps

## ***Section 1: General Information***

---

**Data Clock:** AT1, AT2  
**Connector:** DB9 Female, rear panel  
**Alarm Signal:** Ground under normal operation, open circuit when alarm is asserted.  
**Current Rating:** Sink 500 milliamps maximum

**1544 kHz:** AT1  
**Connector:** RJ-11, rear panel  
**Contacts:** NO, NC, and Common  
**Contact Rating:** 30 VDC, 250 milliamps

### **1.5.9 Communication Ports**

The Model 8195 has a front panel RS-232 and a rear panel RS-485 communication port. The communication ports are used to monitor and set operational parameters.

#### **1.5.9.1 RS-232 Com**

**Signal:** RS-232C, DCE  
**Connector:** DB9 female, front panel  
**Bit Rate:** 9600 Baud  
**Character Structure:** ASCII, 1 start, 8 data, 1 stop, no parity.

#### **1.5.9.2 RS-485 Com**

**Signal:** RS-485, 1 pair Transmit, 1 pair Receive  
**Connector:** RJ-11, rear panel  
**Impedance:** Hi Z /120 ohms, switch selectable  
**Bit Rate:** 9600 baud  
**Address:** 0 - 31, switch selectable  
**Character Structure:** ASCII, 1 start, 8 data, 1 stop, no parity  
**Message Format:** Start word, source address, destination address, message length, message, check word, stop word.

**1.5.10 Input Power**

<b>AC Input:</b>	90 to 264 VAC, 50/60 Hz, 20 watts for standard unit. Option 02, Internal Battery Backup, requires an additional 10 watts. Option 03, Internal Distribution Amplifier, requires an additional 20 watts.
Fuse:	1.5 Amp, 250V, Slo-Blo
Connector:	3-conductor, IEC 320 C-13, rear panel
<b>DC Standby:</b>	±10 to 36 VDC, 10 watts
Fuse:	1.5 amp, 250V, Slo-Blo
Connector:	6-position terminal block, rear panel
<b>Optional:</b>	Option 52, ±10 to 36 VDC input.

**1.5.11 Mechanical**

Dimensions:	3.5H x 19.0W x 12.5D inches (89H x 483W x 315D mm)
Weight:	15 lbs.(6.8 kg) maximum
Shipping Weight:	20 lbs. (9.1 kg)
Rack Mount:	EIA 19", front panel drilled for two standard rack units.
Optional:	Option 11 Rack Mount Slides

**1.5.12 Environmental**

Operating Temperature:	-30 to +60°C
Storage Temperature:	-40 to +85°C
Humidity:	95% R. H. non-condensing

## ***Section 1: General Information***

---

### **1.5.13 Product Information**

**Traceability:** Spectracom Corporation hereby certifies that its Model 8195 GPS Ageless Oscillator provides traceability to the United States Naval Observatory reference frequency as transmitted by NAVSTAR Global Positioning System with a carrier frequency of L1 C/A Code transmitted at 1575.45 MHz.

When properly installed and maintained, the Model 8195 complies with time and frequency accuracy specifications as published in this manual. No periodic calibration is required.

**FCC Information:** Many communications transmitters have been FCC type accepted with Spectracom Ageless Oscillators. Other transmitters have been granted permissive changes. Consult the factory with transmitter manufacturer and model information.

**Patent:** The Spectracom "Ageless" Oscillator process is protected and registered under Patent Number 4,525,685.

### **1.5.14 Model 8225 GPS Antenna Specifications**

#### **1.5.14.1 Electrical Specifications**

Type:	Active.
Frequency:	1575.42 MHz.
Temperature Range:	-30° to 70° C (-22° to 158°F).
Gain:	30 dB.
Connector:	N type, Female.
Recommended Cable:	RG-213.
Minimum Cable Length:	40 feet.
Maximum Cable Length:	200 feet before additional preamplifier is required.
Power:	5 Volts, 27 milliamps, powered by receiver.

*1.5.14.2 Mechanical Specifications*

Assembled Length:	26 inches (66 cm).
Housing Diameter:	3.5 inches (8.9 cm).
Housing Material:	PVC.
Assembled Weight:	1.4 lbs. (.650 kg).
Shipping Weight:	3.5 lbs. (1.6 kg).
Mounting:	Hose clamps (furnished) on vent pipe
Accessories:	Model 8213 Antenna Base Model 8226 Antenna Surge Protector Model 8227 Inline GPS Amplifier

# **INSTALLATION**

## **2.0 INTRODUCTION**

This section contains installation and configuration information for the Model 8195 GPS Ageless™ Oscillator and installation guidelines for the Model 8225 GPS Antenna. To ensure proper operation, please read this section prior to equipment usage.

Refer to Section 5 of this manual for information on installing the Option 11 Rack Mount Slides and following antenna accessories:

Model 8213 Antenna Mount  
Model 8226 Antenna Impulse Suppressor  
Model 8227 GPS Inline Amplifier

## **2.1 MODEL 8225 GPS ANTENNA**

The Model 8225 is an active antenna tuned to receive the GPS 1575.42 MHz L1 band satellite transmissions. The received signals are passed through a narrow bandpass filter and a preamplifier within the antenna. The antenna active circuitry requires +5 VDC at 25 milliamps. This is provided by the Model 8195 receiver over the antenna coax. Each antenna includes a 4-inch length of RG-58 coax terminated with a type “N” male connector and female adapter. The Model 8225 features a weatherproof compact design measuring 3.5 inches in diameter.

### **2.1.1 Antenna Installation**

The GPS antenna must be installed outdoors in a location where an unobstructed view of the sky exists. Rooftops generally make good locations due to clear overhead sky with views to the horizon. This type of location allows the antenna to see and track the maximum number of satellites throughout the day. Installations with obstructed views may prove operational, but may experience reduced reception quality and the inability to simultaneously track the maximum number of satellites. In addition to clear sky coverage, select a site which would not allow the antenna to become buried in drifted or accumulated snow. Avoid placing the GPS antenna in close proximity to broadcast antennas whenever possible.

Each antenna includes a mating two-foot long PVC mast assembly and two hose clamps to simplify installation. The hose clamps affix the mast assembly to a vent pipe as shown in Figure 2-1. Spectracom offers an aluminum base, Model 8213, for installations where vent pipe mounting is not practical or desired.

## **FIGURE 2-1 ANTENNA INSTALLATION**

### **2.1.2 Antenna Cable**

Spectracom recommends RG-213 coax for the GPS antenna cable. The attenuation characteristics of the RG-213 coax at the L1 frequency (1575.42 MHz) limit the antenna cable length to a maximum of 200 feet<sup>1</sup>. Spectracom offers GPS cable assemblies terminated with weatherproof Male type N connectors. Specify part number CA07xxx, where xxx equals the length in feet. Do not allow the cable to be placed in standing water, as water may permeate through the coax jacket over time. On flat roof installations, the coax can be suspended by cable hangers or placed in sealed PVC conduit. Apply a weather proofing sealant or tape over all outdoor connections.

Spectracom offers the Model 8227 GPS Inline Amplifier for use in installations where the antenna cable length exceeds 200 feet. The GPS antenna and the Inline Amplifier are powered by the receiver. The Inline Amplifier permits an additional 200 feet of coax, extending the antenna-to-receiver distance to 400 feet.

Installation of a surge protection device in the antenna line is recommended to protect the Model 8195 receiver and connected devices from lightning damage. Spectracom offers the Model 8226 Impulse Suppressor to shunt potentially damaging voltages on the antenna coax to ground.

Refer to Section 5, Options and Accessories, for additional information on the Model 8227 GPS Inline Amplifier and Model 8226 Impulse Suppressor.

## **2.2 MODEL 8195 PREPARATION FOR USE**

This section outlines the set-up procedure to prepare the Model 8195 for operation.

### **2.2.1 Antenna Connection**

Install the Model 8225 Antenna as outlined previously in this section. Connect the antenna cable to the rear panel GPS ANT connector.

---

<sup>1</sup> Maximum cable length for Model 8225 GPS Antennas with serial numbers 8225-0839 and below is 140 feet.

### **2.2.2 AC Power**

The standard Model 8195 receives primary power from a 90 to 264 VAC 50/60 Hz power source. A detachable line cord is furnished in the ancillary kit. The supplied line cord is compatible with AC receptacles (NEMA 5-15R) commonly found in the United States and Canada. Alternate type line cords may be obtained locally. Connect the line cord to the rear panel AC module and a properly grounded power receptacle.

---

---

**NOTE:** The Model 8195 accepts the complete range of 90 to 264 VAC without a change in instrument setup. Do not change the AC fuse or line voltage selector.

---

---

### **2.2.3 DC Power**

On AC powered units, the DC power connector allows connection of a backup power source. The backup source powers the oscillator and GPS receiver whenever AC power is interrupted. Backup power speeds recovery time when AC power is restored by eliminating oscillator warm-up and retrace and GPS reacquisition time. The backup power requirement is  $\pm 10$  to 36 VDC, 10 watts maximum.

---

---

**NOTE:** Units equipped with Option 02, Internal Battery Backup, do not include DC power connections.

---

---

Instruments equipped with Option 52 configure the Model 8195 for operation from a  $\pm 10$  to 36 VDC power source. Power consumption is 40 watts maximum.

The DC power connector provides for redundant power connections. Connect the DC power inputs to the 6-position terminal block as shown in Figure 2-2, DC POWER CONNECTOR. The ground connection "G" is attached to chassis ground.

## Section 2: Installation

---

**NOTE:** Place the DC power switch in the OFF position connecting prior to DC power.

FIGURE 2-2 DC

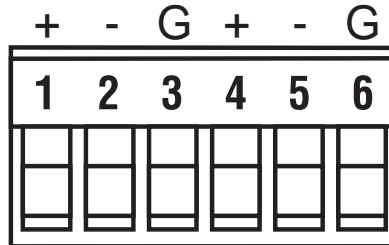

POWER CONNECTOR

### 2.2.4 Chassis

Ground

The chassis ground lug allows the Model 8195 chassis to be connected to an earth ground separate from the power line safety ground. Connecting the chassis to a single point ground system may be required in some installations to ensure optimum lightning protection. A separate earth ground is also recommended in installations where excessive noise on the power line degrades the Model 8195 receiver performance.

## 2.3 INITIAL OPERATION

Upon completing antenna and power connections, turn on the power switch. Observe the front panel POWER lamp turns on. The receiver will now acquire and lock to GPS satellites currently in view of the antenna. If the receiver is unable to acquire a satellite within one (1) minute, an AT1 alarm is asserted, producing a Minor Alarm. The TRACKING GPS lamp turns on when the receiver acquires a minimum of four satellites and has achieved a 3-D fix for one minute. This typically takes less than 20 minutes to accomplish during initial installation. Once the receiver has a 3-D fix in its new location, the position information is loaded into non-volatile RAM. Having current position information greatly reduces the time to first fix on subsequent power cycles to less than one minute, or under 10 seconds if a backup power source is present.

The ovenized oscillator requires a minimum of three to four hours to reach operational temperature and stabilize. The OSC LOCK lamp turns on when the ovenized oscillator is disciplined to the GPS reference. The unit will now operate in accordance with the specifications listed in this manual.

**2.4 FACTORY CONFIGURATION**

Several of the Model 8195 outputs and operational parameters are configurable using the RS-232 communication port and set-up DIP switches. Table 2-1 lists the selectable parameters, factory default, and if it is command or switch selectable. Refer to Section 3, Operation, for a complete description of the various outputs and set-up switches. Refer to Section 4, Software Commands, for information on the various commands.

<b>FUNCTION</b>	<b>FACTORY DEFAULT</b>	<b>COMMAND OR SWITCH</b>
Antenna Cable Delay	No Delay	Command, ACD
Alarm Timeout AT1	1 Minute	Command, AT1
Alarm Timeout AT2	2.5 Hours	Command, AT2
Alarm Timeout AT3	30 Days	Command, AT3
300 or 33-1/3 Hz	300 Hz	Command, BS
Event Output	ON	Command, EO
Signature Control	OFF	Command, SC
Set Mode	OFF	Command, SM
Test Mode	OFF	Command, TM
Time Zone Offset	No Offset	Command, TZO
10-MHz Offset	No Offset	Command, 1FO
One PPS Offset	No Offset	Command, 1PO
RS-485 Address	00	Switch selectable
RS-485 Baud	9600	Switch selectable
RS-485 Termination	OFF	Switch selectable

**TABLE 2-1 DEFAULT SETTINGS**

# **OPERATION**

## **3.0 INTRODUCTION**

This section describes the front and rear panel functions, alarms, and operational information for the Model 8195 GPS Ageless™ Oscillator.

### **3.1 ALARM DESCRIPTION**

The Model 8195 divides alarm conditions into two categories, Major and Minor. A Major Alarm is asserted when fault conditions exist which affect the operation or accuracy of the unit. A Minor Alarm warns of conditions having no immediate effect on total operation, but may require corrective action.

In addition to Major and Minor Alarms, GPS Tracking Alarms are provided to communicate GPS lock status. The alarms are available as three independently programmable timers. The timers begin counting when the Model 8195 is not tracking any satellites. The Alarm Timeouts are designated as AT1, AT2, and AT3. An alarm is asserted as the designated period for each Alarm Timeout expires. The Alarm Timeouts are configurable from zero seconds to 999 days using the RS-232 or RS-485 communication ports. Refer to Section 4 for a description of the Alarm Timeout configuration commands AT1, AT2 and AT3.

Major and Minor Alarm conditions are communicated by the front panel lamps and relay contacts on the rear panel Alarm Output connector. The Alarm Timeouts AT1, AT2, and AT3 relay contacts are also available on the Alarm Outputs connector. In addition, AT1 and AT2 alarms can be monitored on the Timing Outputs connectors. Each of these connectors are described in this chapter.

Alarm status may also be monitored using the Display Performance log command, DP, through the RS-232 communications port. Refer to Section 4 for a complete description of this command.

The alarm lamps and relays are reset when the fault condition is removed or corrected. The performance log is updated when the change in status occurs.

## ***Section 3: Operation***

---

### **3.1.1 Major Alarm**

A Major Alarm is asserted when the following alarms and conditions exist:

Frequency Error Alarm: Measured oscillator frequency error exceeds  $1 \times 10^{-8}$ .

GPS Tracking Timeout 2: The period of time (AT2) allotted for operation without tracking a satellite has expired. Factory default period is 2.5 hours.

GPS Tracking Timeout 3: The period of time (AT3) allotted for operation without tracking a satellite has expired. Factory default period is 30 days.

CPU Fault: The CPU is unable to communicate with the GPS receiver.

Test Mode: Unit has been placed in TEST MODE operation.

Free Run: While in Test Mode, the automatic frequency control feature has been disabled.

Short Gate: While in Test Mode, gate time has been configured for 10 seconds, measurement resolution is reduced.

### **3.1.2 Minor Alarm**

A Minor Alarm is asserted when the following alarms and conditions exist:

Output Fault: An output from any of the four Frequency Outputs connectors is not detected. Fault could be caused by a shorted cable, reflections due to an unterminated cable or Signature Control removed the outputs.

Oscillator Adjust: Warns that oscillator is operating within 10% of the minimum or maximum control setting. The oscillator requires manual adjustment.

GPS Tracking Timeout 1: The period of time (AT1) allotted for operation without tracking a satellite has expired. Factory default is 1.0 minute.

Replace Battery: Internal battery pack, Option 02 only, has failed daily test, needs replacement.

Frequency Offset: A new simulcast or TV offset (Option 31) value is entered. The alarm remains active until the standard oscillator has corrected for the offset.

Test Mode: Unit is placed in Test Mode operation.

## **3.2 FRONT PANEL FUNCTIONS**

The front panel of the Model 8195 is shown in Figure 3-1. The paragraphs below describe the indicators and connectors found on the front panel.

### **3.2.1 Status Lamps**

#### *3.2.1.1 Power*

This green lamp indicates that the unit is connected to the primary power source and is turned on.

#### *3.2.1.2 Tracking GPS*

During initial operation the TRACKING GPS lamp turns on when a 3D fix is acquired. The lamp turns off if no satellites are detected and Alarm Timeout 1, AT1, expires. The lamp turns back on upon reacquiring one satellite.

#### *3.2.1.3 Oscillator Locked*

The green OSC LOCKED lamp is off during start-up. The lamp turns on when the standard oscillator is disciplined to GPS. Entering a new frequency offset, an Alarm Timeout 2 (AT2) or Frequency alarm turn this lamp off until the oscillator frequency is corrected.

### **3.2.2 Alarm Lamps**

#### *3.1.2.1 Major*

This lamp turns on when any of the Major Alarm conditions are in effect. They are Frequency, Tracking Alarm 2, Long Term Tracking, CPU, Test Mode, Free Run, and Short Gate. The lamp turns off when the fault conditions are corrected.

**FIGURE 3-1 MODEL 8195 FRONT PANEL**

**3.2.2.2** *Minor*

This lamp turns on when any of the Minor Alarm conditions are in effect. They are Output Fault, Frequency Offset, Oscillator Adjust, Tracking Alarm 1, Replace Battery, and Test Mode. The lamp turns off when the fault conditions are corrected.

**3.2.3** **Battery Lamps** (*Option 02 only*)

These lamps monitor the status of the optional internal battery backup. Refer to Section 5, Options and Accessories, for additional battery information.

**3.2.3.1** *Ready Lamp*

This green lamp is on when the battery is OK and fully charged.

**3.2.3.2** *Charging Lamp*

This yellow lamp is on when the battery is charging.

**3.2.3.3** *Replace Lamp*

This red lamp turns on and a Minor Alarm asserted when the battery has failed the daily test. The battery must be replaced.

**3.2.4** **RS-232 Com**

This is the RS-232 serial communication port. Commands to configure selectable parameters, output operational status and events, and Test Mode functions are entered here. Refer to Section 4.1 for a complete description of the RS-232 commands and responses.

The RS-232 COM connector is a 9-pin series D female. Connector pin numbering is shown in Figure 3-2. Pin assignments are listed in Table 3-1.

The RS-232 Com port transmits and receives ASCII characters at 9600 baud structured as 1 start, 8 data, 1 stop, and no parity.

**FIGURE 3-2 RS-232 COM PIN NUMBERING**

<b>PIN</b>	<b>SIGNAL</b>	<b>I/O</b>	<b>DESCRIPTION</b>
2	RXD	O	Receive Data
3	TXD	I	Transmit Data
5	GND	-	Signal Common
6	DSR	O	Data Set Ready
7	RTS	*	Request to Send
8	CTS	*	Clear to Send

\*Pins 7 and 8 are connected together internally.

**TABLE 3-1 RS-232 COM PIN ASSIGNMENTS**

The RS-232 Com port is configured as data communication equipment (DCE). Data is output on Pin 2, RXD and commands are input on Pin 3, TXD. When interfacing to data terminal equipment, DTE, (i.e. a personal computer) a one-to-one cable is used. Interfacing to a DCE requires reversing Pins 2 and 3 or a null modem. The RS-232 COM port requires no handshaking. The Request to Send and Clear to Send signals are internally connected together, and the DSR signal is held high through a pull-up resistor.

### **3.2.5 10-MHz Output**

This BNC connector outputs a 10-MHz sine wave signal derived from the disciplined oscillator. The 10-MHz output can be user-configured for simulcast paging or optional TV offsets. Refer to the Ten MHz Offset command, 1F0, found in Section 4.2 for additional information.

### **3.2.6 1PPS Output**

This BNC connector outputs a GPS one pulse-per-second TTL-compatible signal. The leading edge of the signal is the on time point adjusted by any cable or offset delays which have been user-configured. Refer to the Antenna Cable

## ***Section 3: Operation***

---

Delay command, ACD, and the One PPS Offset command, 1PO, descriptions found in Section 4.2 for additional information.

### **3.3 REAR PANEL FUNCTIONS**

The rear panel of the Model 8195 is shown in Figure 3-3. The following paragraphs describe each of the rear panel functions.

#### **3.3.1 GPS Antenna**

This type N connector is the antenna input to the GPS receiver. The Model 8225 GPS Antenna and the Model 8227 Inline Preamplifier receive operational power from this connector. The connector provides +5 VDC to power the antenna system.

#### **3.3.2 Frequency Outputs**

The Frequency Outputs are derived from the GPS disciplined oscillator. Four BNC outputs at 10.0 MHz are provided. The signal is 600 mV rms sinewave into a 50-ohm load. The harmonic suppression is 30 dB.

##### *3.3.2.1 Signature Control*

The Frequency Outputs may be placed under signature control. Signature Control removes the outputs whenever a Major Alarm occurs. The outputs return when the fault condition is cleared. The Model 8195 is shipped with this feature disabled. The Signature Control feature may be enabled using the front panel RS-232 Com port. Refer to the Signature Control command, SC, found in Section 4, Software Commands.

### **FIGURE 3-3 MODEL 8195 REAR PANEL**

##### *3.3.2.2 Simulcast Offsets*

In simulcast radio systems, it is desirable to cover large geographic areas with multiple base station transmitters. Simulcasting requires precise control of

transmitter frequencies to reduce interference between adjacent transmitters on the same channel.

Ineffective transmitter frequency control can reduce system coverage and cause "dead spots," "false pages," and message distortion. These adverse effects are reduced or eliminated by providing a carrier frequency offset between adjacent transmitters. The offset values are selected to minimize co-channel interference. To assure maximum performance of the system, the effects of transmitter oscillator "aging" must be neutralized by periodically checking and adjusting the transmitter oscillators to maintain the desired frequency offsets.

The Spectracom Model 8195 Simulcast Transmitter Offset provides an accurate, controlled frequency reference which is continuously "frequency locked" to GPS. This reference can be used by synthesized transmitters to provide "ageless" frequency control, including offsets, to better than one part per billion.

The simulcast offsets are divided into two groups; Simulcast 1 (SC1) and Simulcast 2 (SC2). Simulcast 1 has offset steps sized for UHF as listed in Table 3-2. Simulcast 2 has offset steps sized for VHF Hi as listed in Table 3-3. Within each group exists four positive offset steps and the complimentary negative offset steps.

The simulcast offsets are selected using software commands. Refer to the 10-MHz Offset command, 1F0, found in Section 4 for additional information.

<b>Offset Name</b>	<b>Offset <math>\Delta f_s</math></b>	<b>Output Frequency</b>	<b>Offset @ 450 MHz</b>
SC1 + 1	+1.1E-9	10,000,000.011 Hz	+0.5 Hz
SC1 + 2	+2.2E-9	10,000,000.022 Hz	+1.0 Hz
SC1 + 3	+3.3E-9	10,000,000.033 Hz	+1.5 Hz
SC1 + 4	+4.4E-9	10,000,000.044 Hz	+2.0 Hz
SC1 - 1	-1.1E-9	9,999,999.989 Hz	-0.5 Hz
SC1 - 2	-2.2E-9	9,999,999.978 Hz	-1.0 Hz
SC1 - 3	-3.3E-9	9,999,999.967 Hz	-1.5 Hz
SC1 - 4	-4.4E-9	9,999,999.956 Hz	-2.0 Hz

**TABLE 3-2 UHF SIMULCAST OFFSETS**

<b>Offset Name</b>	<b>Offset <math>\Delta f_s</math></b>	<b>Output Frequency</b>	<b>Offset @ 150 MHz</b>
SC2 + 1	+2.0E-8	10,000,000.200 Hz	+3.0 Hz

### **Section 3: Operation**

---

SC2 + 2	+3.4E-8	10,000,000.340 Hz	+5.0 Hz
SC2 + 3	+4.7E-8	10,000,000.470 Hz	+7.0 Hz
SC2 + 4	+6.0E-8	10,000,000.600 Hz	+9.0 Hz
SC2 - 1	-2.0E-8	9,999,999.800 Hz	-3.0 Hz
SC2 - 2	-3.4E-8	9,999,999.660 Hz	-5.0 Hz
SC2 - 3	-4.7E-8	9,999,999.530 Hz	-7.0 Hz
SC2 - 4	-6.0E-8	9,999,999.400 Hz	-9.0 Hz

**TABLE 3-3 VHF HI SIMULCAST OFFSETS**

The frequency offset at the carrier frequency is determined by the formula:

$$\Delta f_C = F_C \times \Delta f_S$$

where:  $\Delta f_C$  = carrier offset  
 $F_C$  = carrier frequency  
 $\Delta f_S$  = offset of 10 MHz standard (from the tables)

#### **3.3.2.3 Output Options**

Several output options are available to configure the Frequency Outputs for various applications. The output options are listed below. Refer to Section 5, Options and Accessories, for a complete description.

- Option 03, Built-in Distribution Amplifier
- Option 07, 5-MHz Outputs
- Option 08, 1-MHz Outputs
- Option 31, TV 10-Hz Offsets

**3.3.3 1544 kHz Timing Output**

This RJ-11 receptacle provides an RS-485 1544 kHz signal and relay contacts for Alarm Timeout AT1. The 1544-kHz signal is synthesized from the 10-MHz GPS Disciplined Oscillator.

**NOTE:** Selecting Simulcast or Television Offsets affects the accuracy of the 1544 kHz output.

The connector pin numbering is shown in Figure 3-4 and pin assignments listed in Table 3-4.

**FIGURE 3-4 1544-KHZ CONNECTOR**

<b>PIN</b>	<b>SIGNAL</b>	<b>NOTES</b>
1	+ 1544 kHz	RS-485 B Terminal
2	- 1544 kHz	RS-485 A Terminal
3	Ground	Cable Shield/Relay Ground
4	AT1 Relay (C)	Common
5	AT1 Relay (NO)	Normally Open
6	AT1 Relay (NC)	Normally Closed

**TABLE 3-4 1544 KHZ PIN ASSIGNMENTS**

## Section 3: Operation

### 3.3.3.1 RS-485 1544 kHz

RS-485 is a balanced differential transmission requiring twisted pair cabling. Refer to Figure 3-5 for a schematic representation of the RS-485 output driver. Relative to RS-485 specifications, the A terminal (Pin 2) is negative with respect to the B terminal (Pin 1) for a Binary 1. The A terminal is positive to the B terminal for a Binary 0.

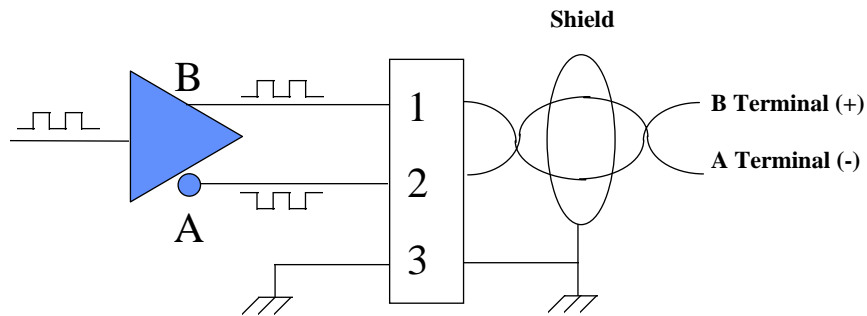

**FIGURE 3-5 RS-485 OUTPUT**

The RS-485 output driver can provide a TTL-compatible clock signal when connected in a single-ended configuration. Connect as shown in Figure 3-6 for a TTL 1544 kHz Clock Reference.

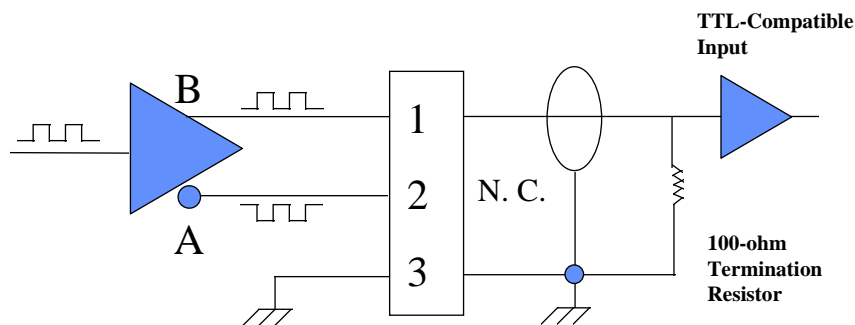

**FIGURE 3-6 SINGLE-ENDED CONNECTION**

The 100-ohm termination resistor is required at the cable destination to prevent ringing and reflections.

### 3.3.3.2 AT1 Alarm

The Alarm Timeout AT1 is activated when the period of time allotted for operation without satellite lock has expired. The period of time is configured using the RS-232 or RS-485 communication ports. AT1 timer may range from zero seconds to 999 days, factory default is one minute. Under normal operation, the AT1 Alarm relay is energized, producing continuity between Pins 4 and 5. When an AT1 Alarm is asserted, continuity exists between Pins 4 and 6.

### 3.3.4 Data Clock Timing Outputs

This connector provides RS-485 One Pulse Per Second (1PPS), 300 Hz, 9.6 kHz clock signals and Alarm Timeouts AT1 and AT2. The connector is a 9-pin Series D numbered as shown in Figure 3-7. Data clock pin assignments are listed in Table 3-5.

**FIGURE 3-7 DATA CLOCK CONNECTOR**

PIN	SIGNAL	NOTES
1	+ 9.6 kHz	RS-485 B Terminal
2	+ 300 Hz*	RS-485 B Terminal
3	+ 1 PPS	RS-485 B Terminal
4	AT2 Alarm	Ground = Normal
5	AT1 Alarm	Ground = Normal
6	- 9.6 kHz	RS-485 A Terminal
7	- 300 Hz*	RS-485 A Terminal
8	- 1 PPS	RS-485 A Terminal
9	Ground	Cable Shield

\* This output may be configured for 33.33 Hz.

**TABLE 3-5 DATA CLOCK PIN ASSIGNMENTS**

The Data Clock timing signals are derived from the 10 MHz GPS disciplined oscillator. The leading edges of the outputs are synchronized to the GPS 1PPS leading edge to within 1 microsecond. The GPS 1PPS can be offset from UTC zero to one second in 0.1 microsecond steps. Refer to One PPS Offset Command, 1PO, found in Section 4, for additional information.

### **Section 3: Operation**

---

The 300 Hz output can be configured to 33.33 Hz via the RS-232 Com port. Refer to the Baud Generation Select command, BS, found in Section 4.

#### **3.3.4.1 RS-485 Outputs**

RS-485 is a balanced differential transmission requiring twisted pair cable. Cable lengths up to 4000 feet are possible when using cables specifically designed for RS-485 applications, like Belden 9844 or equivalent. These cables have a braided shield, nominal impedance of 120 ohms, and a capacitance of 12 to 15 picofarads per foot. Refer to Figure 3-8 for a schematic representation of an RS-485 line driver. Relative to RS-485 specifications the A Terminal (-) is negative with respect to the B Terminal (+) for a Binary 1. The A Terminal (-) is positive to the B Terminal for a Binary 0.

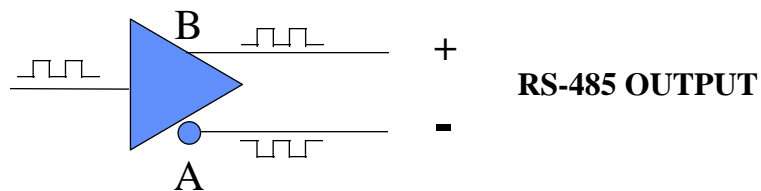

**FIGURE 3-8 RS-485 LINE DRIVER**

#### **3.3.4.2 AT1 and AT2 Alarms**

The status of the Alarm Timeouts AT1 and AT2 can be monitored on this connector. Refer to Section 3.1 for a complete description of Alarm Timeouts.

Under normal operation, the AT1 Alarm (Pin 5) and AT2 Alarm (Pin 4) are connected to ground. When a Timeout Alarm is asserted, the relay breaks the connection to ground and the output pin becomes high impedance (open circuit).

### 3.3.5 Set Up Switches

The Set-Up Switches configure the RS-485 address, baud rate and termination.

#### 3.3.5.1 RS-485 Address

The Address switches give each Model 8195 installed on an RS-485 bus a unique identity. The address may range from 0 - 31. DIP switches 1 through 5 enter the binary equivalent of the selected address. Table 3-6 lists the RS-485 addresses and the corresponding DIP switch settings.

The RS-485 protocol includes address source and destination information.

RS-485 ADDRESS	DIP SWITCH					RS-485 ADDRESS	DIP SWITCH				
	1	2	3	4	5		1	2	3	4	5
0	0	0	0	0	0	16	0	0	0	0	1
1	1	0	0	0	0	17	1	0	0	0	1
2	0	1	0	0	0	18	0	1	0	0	1
3	1	1	0	0	0	19	1	1	0	0	1
4	0	0	1	0	0	20	0	0	1	0	1
5	1	0	1	0	0	21	1	0	1	0	1
6	0	1	1	0	0	22	0	1	1	0	1
7	1	1	1	0	0	23	1	1	1	0	1
8	0	0	0	1	0	24	0	0	0	1	1
9	1	0	0	1	0	25	1	0	0	1	1
10	0	1	0	1	0	26	0	1	0	1	1
11	1	1	0	1	0	27	1	1	0	1	1
12	0	0	1	1	0	28	0	0	1	1	1
13	1	0	1	1	0	29	1	0	1	1	1
14	0	1	1	1	0	30	0	1	1	1	1
15	1	1	1	1	0	31	1	1	1	1	1

1 = SWITCH ON, 0 = SWITCH OFF

**TABLE 3-6 ADDRESS SELECTION**

#### 3.3.5.2 RS-485 Baud Rate

DIP switch 6 is reserved for future implementation of 19200 baud operation of the RS-485 COM port. To ensure proper operation, place this switch in the OFF position. This configures the COM port for 9600 baud.

## Section 3: Operation

---

### 3.3.5.3 Spares

DIP Switches 7, 8, and 9 are reserved for test and future expansion. To ensure proper operation, place these switches in the OFF position.

### 3.3.5.4 Termination

Switch 10 terminates the RS-485 Receive line with 120 ohms. Place Switch 10 in the ON position when the unit is installed at the end of the RS-485 bus. Place this switch in the OFF position when the unit is not the last device on the bus.

### 3.3.6 RS-485 COM

The RS-485 communication port permits remote configuration control and monitoring of performance and status. The RS-485 Com port uses a protocol and command set described in Section 4.2 of this manual. The COM connector pin numbering is shown in Figure 3-9. Table 3-7 lists the Com pin assignments.

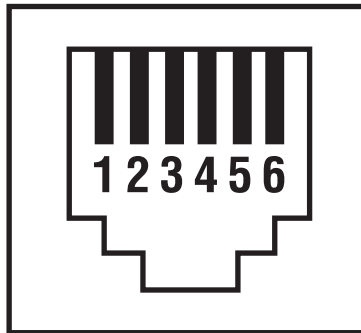

**FIGURE 3-9 COM CONNECTOR**

<b>PIN</b>	<b>SIGNAL</b>	<b>NOTES</b>
1	- Transmit	RS-485 A Terminal
2	+ Transmit	RS-485 B Terminal
3	- Receive	RS-485 A Terminal
4	+ Receive	RS-485 B Terminal
5	Ground	Cable Shield
6	Ground	Cable Shield

**TABLE 3-7 RS-485 COM PIN ASSIGNMENTS**

The RS-485 address and termination are selected by the rear panel DIP switch as described in previous paragraphs. Characters are ASCII having a bit structure of 1 start, 8 data, 1 stop and no parity, data rate is 9600 baud

RS-485 is a balanced differential transmission requiring twisted pair cable. The RS-485 standard defines the A terminal (-) to be negative with respect to the B terminal (+) for a Binary 1 (MARK or OFF) state. The A terminal (-) is positive to the B terminal (+) for a Binary 0 (SPACE or ON) state. Figure 3-10 illustrates the relationship between the A and B terminals for the Transmit and Receive connections.

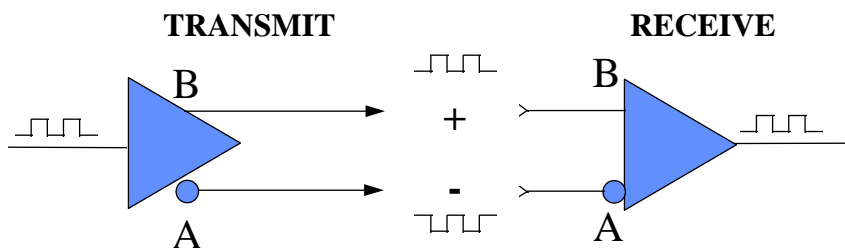

**FIGURE 3-10 RS-485 CONNECTION**

**3.3.7 Alarm Outputs**

The Alarm Outputs connector provides relay contact closures for Major, Minor, AT1, AT2 and AT3 alarms. Relay contacts are rated at 2 amps, 30 VDC. The mating 13-position terminal block, shown in Figure 3-11, is furnished in the ancillary kit.

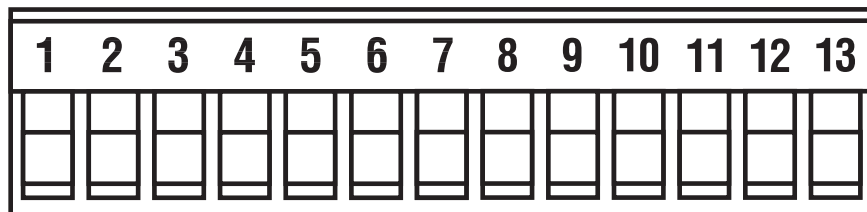

**FIGURE 3-11 ALARM OUTPUTS TERMINAL BLOCK**

### ***Section 3: Operation***

---

Table 3-8 lists each alarm condition and resulting contact status. The alarm relays reset when alarm condition is corrected. Refer to Section 3.1 for a complete description of alarm operation.

<b>ALARM CONDITION</b>	<b>PINS CONNECTED</b>	<b>PINS OPEN</b>
AT1 Alarm or Power Off		1,2
No AT1 Alarm	1, 2	
AT2 Alarm or Power Off		3, 4
No AT2 Alarm	3, 4	
AT3 Alarm or Power Off		5, 6
No AT3 Alarm	5, 6	
Major Alarm or Power Off	8, 7	8, 9
No Major Alarm	8, 9	8, 7
Minor Alarm or Power Off	11, 10	11, 12
No Minor Alarm	11, 12	11, 10

Signal ground is found on Pin 13.

**TABLE 3-8 ALARM OPERATION**

#### **3.3.8 DC Power**

On AC powered units, the DC power connector allows connection of a backup power source. The backup source powers the oscillator and GPS Receiver whenever AC power is interrupted. Backup power speeds recovery time when AC power is restored by eliminating oscillator warm-up and retrace and GPS reacquisition time. The backup power requirement is  $\pm 10$  to 36 VDC, 10 watts maximum.

---

---

**NOTE:** Units equipped with Option 02, Internal Battery Backup, do not include DC power connections.

---

---

Instruments equipped with Option 52 configure the Model 8195 for operation from a  $\pm 10$  to 36 VDC power source. Power consumption is 40 watts maximum.

The DC power connector provides for redundant power connections. Connect the DC power inputs to the 6-position terminal block as shown in Figure 3-12, DC POWER CONNECTOR. The ground connection "G" is attached to chassis ground. the DC input is fuse-protected and equipped with a power switch to disable the internal switching DC converters. An appropriately sized spare fuse is included in the ancillary kit.

---

**NOTE:** Place the DC power switch in the OFF position prior to connecting DC power.

---

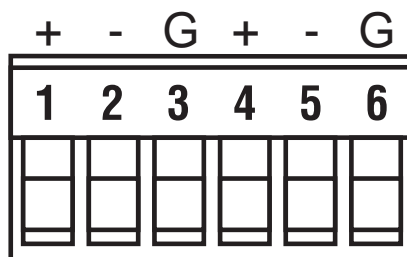

**FIGURE 3-12 DC POWER CONNECTOR**

### **3.3.9 AC Input**

The standard Model 8195 receives primary power from a 90 to 264 VAC 50/60 Hz power source. A detachable line cord is furnished in the ancillary kit. The supplied line cord is compatible with AC receptacles (NEMA 5-15R) commonly found in the United States and Canada. Alternate type line cords may be obtained locally. Connect the line cord to the rear panel AC module and a properly grounded power receptacle.

The AC power module is equipped with a power switch, line voltage selector, EMI filtering, and a fuse. Figure 3-13, AC POWER MODULE, illustrates fuse replacement. The AC fuse requires a 1.5 amp, 250V Slo-Blo fuse. A spare is found in the ancillary kit.

**NOTE:** The Model 8195 accepts the complete range of 90-264 VAC without a change in instrument setup. Do not change the AC fuse value or line voltage selector. The 115 must appear in the cover cut-out.

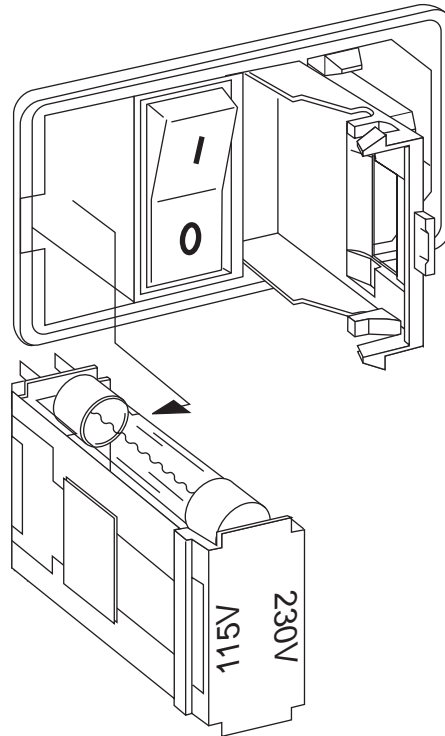

**FIGURE 3-13 AC POWER MODULE**

### **3.3.10 Chassis Ground**

The chassis ground lug allows the Model 8195 chassis to be connected to an earth ground separate from the power line safety ground. Connecting the chassis to a single point ground system may be required in some installations to ensure optimum lightning protection. A separate earth ground is also recommended in installations where excessive noise on the power line degrades the Model 8195 receiver performance.

# SOFTWARE COMMANDS

## 4.0 INTRODUCTION

This chapter covers commands which can be given from the front panel RS-232 interface and the rear panel RS-485 interface.

## 4.1 RS-232 COMMANDS

From the front panel RS-232 Com port the user may configure, control and monitor the 8195. The following list of commands provides the user with access to the operation of the unit. These commands contain a hierarchy of Read, Set and Test modes. Figure 4-1 illustrates the Model 8195 command structure. Read Mode is the base level and when in Read Mode the user may only Read standard commands. From Read Mode the user may select to enter Test or Set Mode. Set Mode allows the user to not only Read standard commands, but in addition, allows them to make changes to certain 8195 functions. Test Mode allows the user access to special test commands, as well as all standard commands. After entering Set Mode or Test Mode, the unit will time out and return to Read Mode after 15 minutes of inactivity.

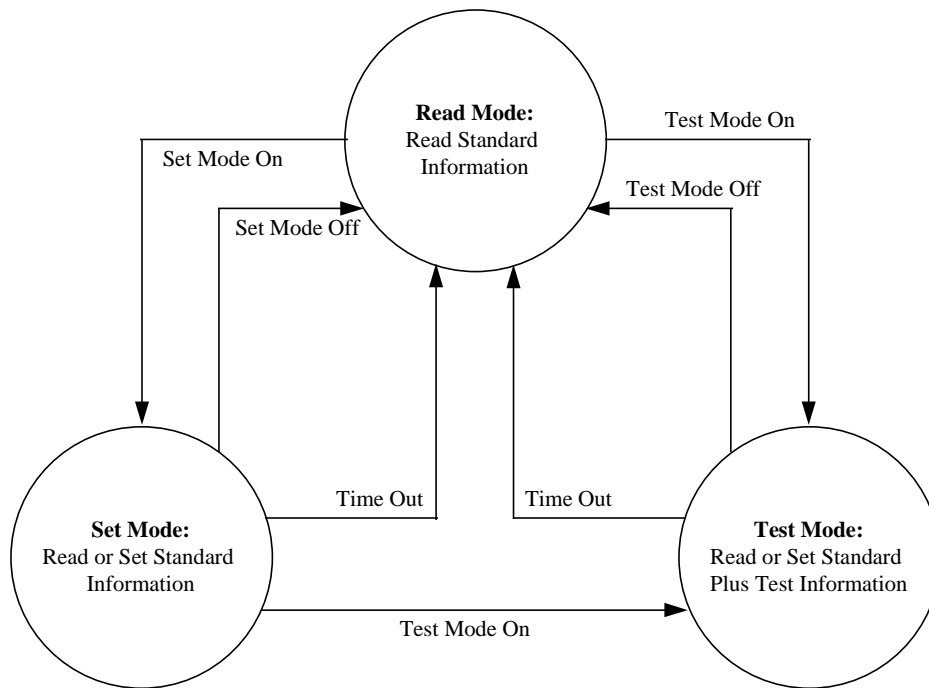

FIGURE 4-1 COMMAND STRUCTURE

## Section 4: Software Commands

COMMAND	DESCRIPTION	NOTES
ACD	Antenna Cable Delay	
AT1	Alarm Time Out 1	
AT2	Alarm Time Out 2	
AT3	Alarm Time Out 3	
BA	Battery Status	
BS	300/33·1/3 Baud Generation Select	
CA	Clear Alarms	
D	Date	
DA	D/A reading or setting	Test Mode
DC	Display Configuration	
DH	Display Histogram Log	
DMI	Display Internal Memory	Test Mode
DMX	Display External Memory	Test Mode
DP	Display Performance Log	
DS	Display Status	
EO	Event Output	
FR	Free Run	Test Mode
H,He,?	Help	
HR	Hertz Range for D/A adjustment	Test Mode
IT	Internal Temperature	
LAT	Latitude	
LB	RS-485 Loopback Test	Test Mode
LON	Longitude	
LT	Lamp Test	Test Mode
R	Reset Command	Test Mode
R GPS	Reset GPS Receiver	Test Mode
SC	Signature Control	
SG	Short Gate	Test Mode
SHI	Set to High D/A setting	Test Mode
SLO	Set to Low D/A setting	Test Mode
SM	Set Mode	
SS	Signal Strength	Test Mode
T	Time of Day	
TB	Test Battery	Test Mode
TL	Time Log (RT. Seconds)	Test Mode
TM	Test Mode	
TZO	Time Zone	
VER	Version	
1FO	Ten MHz Offset	
1PO	One PPS Offset	

**TABLE 4-1 ALPHABETICAL LIST OF RS-232 COMMANDS**

In the following descriptions characters in ***Bold Italics*** are keys typed by the user. Terminate all command lines with the enter key. The enter key is represented by **<ent>**. The responses from the Model 8195 are in *Italics*. A new line is represented by a the carriage return symbol *<cr>*. Configure the terminal for ANSI, full duplex, 9600 baud and no flow control. The character structure is ASII, 1 start, 8 data, 1 stop and no parity.

INVALID COMMANDS

Any input not specified in the rest of this chapter.

***BLAH<ent>***

*INVALID COMMAND STRUCTURE, ? FOR HELP<cr>*

NOT IN SET MODE RESPONSE

If the user attempts to make a change to the Model 8195 while not in set mode this message is output.

***Command Parameter<ent>***

*MUST BE IN SET MODE TO CHANGE SETTINGS<cr>*

TEST MODE COMMANDS NOT IN TEST MODE RESPONSE:

Any Test Mode Command Entered while not in Test Mode will respond with this message.

*THIS COMMAND IS ONLY AVAILABLE IN TEST MODE<cr>*

USAGE MESSAGES

If the user enters an invalid parameter with a valid command there will be a usage message. The usage message is a short description of how to use the command properly.

***Command Invalid-Parameter<ent>***

*USAGE> Command [Valid Parameters]<cr>*

ANTENNA CABLE DELAY COMMAND

This command is to read or set the antenna cable delay. Although this value is generally negligible, the 1PPS timing can be affected by the antenna cable delay. The default is 0. The maximum delay value is 999.999 microseconds. This information is also provided in the Display Configuration command.

***ACD<ent>***

*ANT CABLE DELAY= dddddd.ddd MICROSECONDS<cr>*

***ACD dddddd.ddd<ent>*** NOTE: offset may be entered using 1 to 9 digits.

*ANT CABLE DELAY= dddddd.ddd MICROSECONDS<cr>*

## **Section 4: Software Commands**

---

### **ALARM TIMEOUTS**

This command is to read or set the three alarm timeouts individually. Each timeout controls the status of an alarm relay. If the GPS receiver stops tracking satellites, these timers start counting down. If the timer reaches 0 before the receiver begins to track satellites again, the alarm relay is activated. In addition, if Alarm Timeout 1 occurs, this is a Minor alarm. Alarm Timeout 2 and Alarm Timeout 3 are Major alarms. Defaults are: AT1 = 1 minute, AT2 = 2½ hours, AT3 = 30 days. This information is provided in the Display Configuration command.

**ATx<ent>** where x= 1,2, or 3

*ALARM TIMEOUT x= DDD HH:MM:SS<cr>*

**ATx DDD HH:MM:SS<ent>**

*ALARM TIMEOUT x= DDD HH:MM:SS<cr>*

### **BATTERY STATUS**

This command is to read current battery status. If the unit has an internal battery backup this will indicate one of three conditions. READY indicates the battery good and fully charged, CHARGING indicates the battery is OK, but is not yet fully charged, and REPLACE indicates the battery failed a test and should be replaced. The replace battery condition is a minor alarm. This information is also provided in the Display Status command.

**BA <ent>**

*BATTERY STATUS= READY or CHARGING or REPLACE or NO BATTERY<cr>*

### **300/33.3 BAUD SELECT COMMAND**

This command is to read or set the Baud Generators 33.3/300 output. The Baud generators output a 9600 Hz signal and either a 300 Hz or a 33.3 Hz signal. This allows the user to select the desired output. The default is 300. This information is also provide in the Display Configuration command.

**BS<ent>**

*BAUD SELECTED= 33.3 or 300<cr>*

**BS 33.3 or 300<ent>**

*BAUD SELECTED= 33.3 or 300<cr>*

### **CLEAR ALARMS**

This command is used to reset rear panel alarm signals. It allows the user to reset the rear panel major and minor alarm relays even though the condition causing the alarm is still present. If a new alarm condition arises the relays alarms will be reasserted. The front panel alarm lights are not affected.

**CA<ent>** If an alarm is cleared, responds with a status message (a log entry is also created). Response if no current alarms *NO ALARMS CLEARED<cr>*

**DATE COMMAND**

This command is to read or set the date. After the unit has acquired satellites it will receive time and date information from them. When the unit is initially powered on it will acquire satellites faster if it has the correct time and date information. This information is also provided in the Display Status command.

**D<ent>**

*DATE= MM-DD-YY<cr>*

**D MM-DD-YY<ent>**

*DATE= MM-DD-YY<cr>*

**D/A REQUEST**

This command is to read current D/A setting. The D/A is used to control the 10MHz oscillator. The value displayed here is in the hex number system and represents the control voltage being applied to the oscillator. The default of the D/A is 9000h, but the current value is maintained during power outages.

**DA <ent>**

*D/A= hhhh<cr>*

**D/A SETTING COMMAND**

This TEST MODE command sets the D/A. The D/A is used to control the 10MHz oscillator, this command allows the user to manually adjust the D/A. Manually adjusting the D/A is not recommended, but is left as a Test Mode feature. Changing the D/A setting creates a performance log entry.

**DA hhhh <ent>**

*D/A= hhhh<cr>* where hhhh= 0000 to FFFF (hex Number)

**DISPLAY CONFIGURATION**

This command to display configuration information. This command is comprised of all of the configuration settings in the 8195. All of the information here can be displayed and/or set with other commands, except for the RS-485 information which is set by rear panel dip switches.

**DC<ent>**

*TIME ZONE= sHH:MM<cr>*

*1PPS OFFSET= 000000.000 MICROSECONDS<cr>*

*ANT CABLE DELAY= dddddd.ddd MICROSECONDS<cr>*

*10MHZ OFFSET= NONE or SCn so or TV sc<cr>*

*SIGNATURE CONTROL ON or OFF<cr>*

*EVENT OUTPUT ENABLED or DISABLED<cr>*

*RS485 ADDRESS= XX BAUD RATE= 9600 or 19200<cr>*

*BAUD SELECTED= 33.3 or 300<cr>*

*TIME OUT 1= DDD HH:MM:SS<cr>*

*TIME OUT 2= DDD HH:MM:SS<cr>*

*TIME OUT 3= DDD HH:MM:SS<cr>*

## **Section 4: Software Commands**

---

### **DISPLAY HISTOGRAM LOG INFORMATION**

This command is to output the Histogram. The histogram consists of recording the number of satellites being tracked each second. At the end of every hour an entry in the log is created and the counters start again. In normal operation the command will respond with the last 6 entries of the histogram and current histogram from the time of the last histogram entry. If the unit is in Test Mode this command will respond with the entire histogram log, which consists of 40 entries. The [P]age parameter causes the histogram to be displayed 1 page at a time. In paged mode the user may quit or continue the display after each page is displayed.

***DH<ent>***

***DH P<ent>*** (paged output)

Logged entries in this format for 8 channel receiver:

*TIME= HH:MM:SS DATE= MM-DD-YY TRACKING HISTOGRAM<cr>*

*0= XXXXX 1= XXXXX 2= XXXXX 3= XXXXX 4= XXXXX 5= XXXXX 6= XXXXX<cr>*

*7=XXXXX 8=XXXXX<cr>*

### **DISPLAY INTERNAL MEMORY**

This is a TEST MODE command to display the processor internal memory. The output will be 256 bytes of Internal memory displayed as hex numbers. This command is used for factory troubleshooting only.

***DMI<ent>***

00 XX XX XX XX XX XX XX XX XX XX XX XX XX XX XX<cr>

10 XX XX XX XX XX XX XX XX XX XX XX XX XX XX XX<cr>

20 XX XX XX XX XX XX XX XX XX XX XX XX XX XX XX<cr>

30 XX XX XX XX XX XX XX XX XX XX XX XX XX XX XX<cr>

40 XX XX XX XX XX XX XX XX XX XX XX XX XX XX XX<cr>

50 XX XX XX XX XX XX XX XX XX XX XX XX XX XX XX<cr>

60 XX XX XX XX XX XX XX XX XX XX XX XX XX XX XX<cr>

70 XX XX XX XX XX XX XX XX XX XX XX XX XX XX XX<cr>

80 XX XX XX XX XX XX XX XX XX XX XX XX XX XX XX<cr>

90 XX XX XX XX XX XX XX XX XX XX XX XX XX XX XX<cr>

A0 XX XX XX XX XX XX XX XX XX XX XX XX XX XX XX<cr>

B0 XX XX XX XX XX XX XX XX XX XX XX XX XX XX XX<cr>

C0 XX XX XX XX XX XX XX XX XX XX XX XX XX XX XX<cr>

D0 XX XX XX XX XX XX XX XX XX XX XX XX XX XX XX<cr>

E0 XX XX XX XX XX XX XX XX XX XX XX XX XX XX XX<cr>

F0 XX XX XX XX XX XX XX XX XX XX XX XX XX XX XX<cr>

**DISPLAY EXTERNAL MEMORY**

This is a TEST MODE command to display the memory addresses external to the main processor. The user indicates which page to output, the output will be 256 bytes of external memory displayed as hex numbers. This command is used for factory troubleshooting only.

**DMX pp<ent>** where pp = to any valid external page.

```
pp00 XX XX XX XX XX XX XX XX XX XX XX XX XX XX XX XX<cr>
pp10 XX XX XX XX XX XX XX XX XX XX XX XX XX XX XX XX<cr>
pp20 XX XX XX XX XX XX XX XX XX XX XX XX XX XX XX XX<cr>
pp30 XX XX XX XX XX XX XX XX XX XX XX XX XX XX XX XX<cr>
pp40 XX XX XX XX XX XX XX XX XX XX XX XX XX XX XX XX<cr>
pp50 XX XX XX XX XX XX XX XX XX XX XX XX XX XX XX XX<cr>
pp60 XX XX XX XX XX XX XX XX XX XX XX XX XX XX XX XX<cr>
pp70 XX XX XX XX XX XX XX XX XX XX XX XX XX XX XX XX<cr>
pp80 XX XX XX XX XX XX XX XX XX XX XX XX XX XX XX XX<cr>
pp90 XX XX XX XX XX XX XX XX XX XX XX XX XX XX XX XX<cr>
ppA0 XX XX XX XX XX XX XX XX XX XX XX XX XX XX XX XX<cr>
ppB0 XX XX XX XX XX XX XX XX XX XX XX XX XX XX XX XX<cr>
ppC0 XX XX XX XX XX XX XX XX XX XX XX XX XX XX XX XX<cr>
ppD0 XX XX XX XX XX XX XX XX XX XX XX XX XX XX XX XX<cr>
ppE0 XX XX XX XX XX XX XX XX XX XX XX XX XX XX XX XX<cr>
ppF0 XX XX XX XX XX XX XX XX XX XX XX XX XX XX XX XX<cr>
```

**DISPLAY PERFORMANCE LOG INFORMATION**

This command is to output the performance log. An entry is created in the performance log when a variety of events occur. In normal operation, this command responds with the last 25 entries in the log. In test mode, this command responds with the complete log, which consists of 358 entries. The [P]age parameter outputs the log 1 page at a time. In paged mode the user may quit or continue the display after each page is displayed.

**DP<ent>**

**DP P<ent>** (paged output)

Valid Frequency Measurement: This happens when the 8195 takes a frequency measurement. These measurements are used to calculate adjustments to the oscillator control voltage. Under normal operation (Long Gate) the measurements occur every 1000 seconds. The testing condition of Short Gate takes a measurement every 10 seconds.

```
TIME= HH:MM:SS DATE= MM-DD-YY D/A= XXXX FREQ ERROR= +X.XXE-YY<cr>
XXXXX GATE 10MHZ OFFSET= XXXXXX INTERNAL TEMP= +XX.X<cr>
FREQ CNT= XXXXXXXXXXXXXXXX<cr>
```

## **Section 4: Software Commands**

---

Automatic D/A Adjustment is based upon 3 of 4 measurements: When 3 of the last 4 measurements agree within 6 parts in  $10^{-10}$  the match counter is updated and an adjustment to the control voltage is calculated and applied. The D/A adjustment counter is incremented whenever a new D/A value is asserted. The Lost Lock Counter counts the number of times the GPS receiver stopped tracking satellites. The 1PPS long and short counters track the number of times the 1PPS was measured to be high or low by more than 10 milliseconds. These three counts are cumulative since power on.

```
MATCH CNT= XXXXX D/A ADJ CNT= XXXXX<cr>
AVG FREQUENCY ERROR= +X.XXE-YY<cr>
LAST D/A= XXXX D/A ADJ= XXXX NEW D/A= XXXX<cr>
LOST LOCK CNT= XXX 1PPS LONG CNT= XXX SHORT CNT= XXX<cr>
```

D/A Manually Set: This happens when the Test Mode command DA is used to alter the oscillator control voltage.

```
TIME= HH:MM:SS DATE= MM-DD-YY D/A MANUALLY SET TO= XXXX<cr>
```

Resets: This happens when the Test Mode command R is used reset 8195 operations.

```
TIME= HH:MM:SS DATE= MM-DD-YY RESET= ALL<cr>
TIME= HH:MM:SS DATE= MM-DD-YY RESET= GATE<cr>
TIME= HH:MM:SS DATE= MM-DD-YY RESET= LOG<cr>
TIME= HH:MM:SS DATE= MM-DD-YY RESET= POSITION<cr>
TIME= HH:MM:SS DATE= MM-DD-YY RESET= CONFIG<cr>
TIME= HH:MM:SS DATE= MM-DD-YY RESET= KEY<cr>
```

Power on: This happens when the unit is powered on.

```
TIME= HH:MM:SS DATE= MM-DD-YY RTC= SSSSS POWER ON RESET<cr>
```

Acquired Satellite: This happens when the GPS receiver has acquired 1 satellite.

```
TIME= HH:MM:SS DATE= MM-DD-YY RTC= SSSSS FIRST SATELLITE
ACQUIRED<cr>
```

3D fix: This happens when the GPS receiver has calculated a 3D fix. The GPS receiver needs to be tracking at least 4 satellites to get a 3D fix. Until the receiver has a 3D fix it may adjust its 1PPS output. After the GPS receiver has a 3D fix for one minute, this message is logged. At this point the 8195 will use the 1PPS output for measuring frequency and for synchronizing the baud outputs.

```
TIME= HH:MM:SS DATE= MM-DD-YY 3D FIX ACQUIRED<cr>
LATITUDE= D DD MM SS.SSS LONGITUDE= D DDD MM SS.SSS HEIGHT= sMMMMM<cr>
```

Status Change: This happens when there is a change of status in any of the alarm relays. The major and minor alarm conditions are described in Section 1 of this manual.

*TIME= HH:MM:SS DATE= MM-DD-YY STATUS CHANGE <TEMP= +XX.X><cr>  
TIMEOUT ALARMS: 1= OFF 2= OFF 3= OFF<cr> or ON  
ALARM RELAYS: MAJOR= OFF MINOR= OFF<cr>  
ACTIVE ALARMS: NONE or MAJOR or MINOR or MAJOR AND MINOR<cr>  
FREQUENCY<cr> and/or TRACKING ALARM 2<cr> and/or  
IN TEST MODE<cr> and/or USING SHORT GATE<cr> and/or  
IN FREE RUN<cr> and/or TRACKING ALARM 3<cr> and/or  
OSCILLATOR ADJUST<cr> and/or OUTPUT FAULT<cr> and/or  
TRACKING ALARM 1<cr> and/or REPLACE BATTERY<cr> and/or  
NEW FREQUENCY OFFSET<cr> or nothing.*

Battery Test Complete: Units equipped with the an internal battery option are tested at 00:00 receiver time every day. The test last for up to 4 minutes and 15 seconds and the results are logged. The test can also occur on demand with the test mode command TB.

*TIME= HH:MM:SS DATE= MM-DD-YY BATTERY TEST STARTED<cr>  
ENDED TIME= HH:MM:SS DATE=MM-DD-YY PASSED STATUS =READY<CR>*

#### DISPLAY STATUS INFORMATION

This command is to display Status Information. The information here represents the current state of the 8195, some of the information may be found in other commands. Oscillator locked indicates the 10MHz oscillator is locked on frequency. The GPS States are self explanatory. The alarm conditions are described in another section of the manual. The time remaining indicates the time until the time-out alarms would be triggered. The time-out alarms begin counting down when the unit is tracking 0 satellites.

#### **DS<ent>**

*TIME= HH:MM:SS DATE= MM-DD-YY {OSCILLATOR LOCKED}<cr>  
TRACKING X SATELLITES {GPS STATE} <cr>  
LATITUDE= D DD MM SS.SSS LONGITUDE= D DDD MM SS.SSS HEIGHT= sMMMMM<cr>  
BATTERY STATUS= NO BATTERY INTERNAL TEMP= sdd.d<cr>  
TIMEOUT ALARMS: 1= OFF 2= OFF 3= OFF<cr>  
TIME REMAINING: 1= 000 00:01:00 2= 000 02:30:00 3= 030 00:00:00<cr>  
ALARM RELAYS: MAJOR= OFF MINOR= OFF<cr>  
ACTIVE ALARMS: NONE or MAJOR or MINOR or MAJOR AND MINOR<cr>  
FREQUENCY<cr> and/or TRACKING ALARM 2<cr> and/or  
IN TEST MODE<cr> and/or USING SHORT GATE<cr> and/or  
IN FREE RUN<cr> and/or TRACKING ALARM 3<cr> and/or  
OSCILLATOR ADJUST<cr> and/or OUTPUT FAULT<cr> and/or  
TRACKING ALARM 1<cr> and/or REPLACE BATTERY<cr> and/or  
NEW FREQUENCY OFFSET<cr> or nothing.  
If Set Mode is ON then: SET MODE= ON<cr>*

## Section 4: Software Commands

---

### EVENT OUTPUT TO TERMINAL

This command is to read or set the automatic event output. The unit maintains a log of various events. With this command the user can enable or disable the automatic display of these events when they occur. The default is enabled.

**EO<ent>**

*EVENT OUTPUT ENABLED or DISABLED<cr>*

**EO ON or OFF<ent>**

*EVENT OUTPUT ENABLED or DISABLED<cr>*

### FREE RUN OSCILLATOR COMMAND

This TEST MODE command is to read or set Free Run Mode. Normal operation of the 8195 consists of measuring the 10MHz oscillator versus the 1PPS from the GPS Receiver, then steering the oscillator via the D/A voltage control to maintain the frequency to within 1 part in  $10^{-10}$ . With Free Run on, the unit will not steer the oscillator, since this is not the way the unit is intended to operate, Free Run is a major alarm condition. The default is Free Run Off.

**FR<ent>**

*FREE RUN ON or OFF<cr>*

**FR ON or OFF<ent>**

*FREE RUN ON or OFF<cr>*

### HELP

This command gives a 1 page Help display.

**H<ent>** or **HE<ent>** or **?<ent>**

*SPECTRACOM CORPORATION GPS DISCIPLINED OSCILLATOR 8195<cr>  
COMMAND LIST FOLLOWS (SET MODE MUST BE ON TO CHANGE  
PARAMETERS)<cr>*

*DC= DISPLAY THE CONFIGURATION<cr>*

*DH [P]= DISPLAY THE HISTOGRAM LOG (P=PAGED)<cr>*

*DP [P]= DISPLAY THE PERFORMANCE LOG (P=PAGED)<cr>*

*DS = DISPLAY STATUS INFORMATION<cr>*

*D [MM-DD-YY] = READ OR SET THE DATE<cr>*

*T [HH:MM:SS] = READ OR SET THE TIME<cr>*

*TZO [+/-HH:MM] = READ OR SET TIME ZONE<cr>*

*LAT [D DD MM SS.SSS] = READ OR SET LATITUDE<cr>*

*LON [D DDD MM SS.SSS] = READ OR SET LONGITUDE<cr>*

*1PO [XXXXXX.XXX] = READ OR SET 1PPS OFFSET<cr>*

*ACD [XXXXXX.XXX] = READ OR SET THE ANTENNA CABLE DELAY<cr>*

*1FO [SCn so|TV sc] = READ OR SET 10MHZ OFFSETS<cr>*

*BS [33.3|300] = READ OR SET BAUD GENERATION<cr>*

*ATX [DDD HH:MM:SS] = READ OR SET ALARM TIME OUTS x= 1,2, OR 3<cr>*

*SC [ON|OFF] = READ OR SET THE SIGNATURE CONTROL<cr>*

*CA= CLEAR ALARMS<cr>*

*EO [ON|OFF] = READ OR SET THE EVENT OUTPUT<cr>*

*SM [ON|OFF] = SET MODE<cr>*

*FOR FURTHER INFORMATION PLEASE CONSULT YOUR MANUAL<cr>*

### HERTZ RANGE COMMAND

This TEST MODE command is to set Hertz Range of Oscillator. The Hertz range of the oscillator is the range of frequencies this oscillator can supply. This range is calculated by setting the D/A to its highest value(SHI), measuring the frequency output. Then setting the D/A to its lowest value(SLO), measuring the frequency and taking the difference between the two readings. The default is 10.000. After this command is entered the D/A is set to the initial control voltage. The Hertz Range is used by the 8195 to determine the D/A adjustments to make in an automatic adjustment.

**HR<ent>**

*HERTZ RANGE= rr.rrr<cr>*

**HR rr.rrr<ent>**

*HERTZ RANGE= rr.rrr<cr> D/A= 9000<cr>*

#### INTERNAL TEMPERATURE

This command reads current internal temperature.

**IT<ent>**

*INTERNAL TEMP= sdd.d DEGREES C<cr>*

#### LATITUDE COMMAND

This command is to read or set the Latitude. The GPS receiver will automatically find its correct position, but the time to first fix can be shortened by entering an approximate position. Entering position data is not required after initial installation because the unit will retain it after loss of power.

**LAT<ent>**

*LATITUDE= D DD MM SS.SSS<cr>*

**LAT D DD MM<ent>**

*LATITUDE= D DD MM 00.000<cr>*

**LAT D DD MM SS<ent>**

*LATITUDE= D DD MM SS.000<cr>*

**LAT D DD MM SS.SSS<ent>**

*LATITUDE= D DD MM SS.SSS<cr>*

#### LOOPBACK TEST

This TEST MODE command is to initiate a loopback test on the RS485 com port. This test requires a loopback connector to be attached to the RS485 com port connection on the rear panel. During the test a message is sent once per second via the RS485. When it is received one of two messages is output to the terminal: *LOOP BACK TEST FAILED* or *PASSED<cr>*. These messages will continue to be output until the test is turned off.

**LB ON or OFF<ent>**

*LOOPBACK TEST ON or OFF<cr>*

## **Section 4: Software Commands**

---

### **LONGITUDE COMMAND**

This command is to read or set Longitude. The GPS receiver will automatically find its correct position, but the time to first fix can be shortened by entering an approximate position. Entering position data is not required after initial installation because the unit will retain it after loss of power.

**LON<ent>**

LONGITUDE= D DDD MM SS.SSS<cr>

**LON D DDD MM<ent>**

LONGITUDE= D DDD MM 00.000<cr>

**LON D DDD MM SS<ent>**

LONGITUDE= D DDD MM SS.000<cr>

**LON D DDD MM SS.SSS<ent>**

LONGITUDE= D DDD MM SS.SSS<cr>

### **LAMP TEST COMMAND**

This TEST MODE command starts and stops the Lamp Test. The lamp test turns the lights and relays off and on in a specific sequence.

**LT<ent>**

LAMP TEST ON or OFF<cr>

**LT ON or OFF<ent>**

LAMP TEST ON or OFF<cr>

### **RESET COMMAND**

This TEST MODE command is to reset certain 8195 functions. Resetting the gate, starts the measurement cycle over again. Resetting the log empties the performance and histogram logs, and resetting the position takes unit out of position hold so it may find its location again. The all command resets the gate, log, and position at once. Resetting the configuration changes all configuration parameters to factory defaults. Resetting the Key will make the unit erase all logs, histograms and configuration on the next power on reset. A performance log entry is created when a Reset of any kind is done.

**R GATE<ent>**

GATE RESTARTED<cr>

**R LOG<ent>**

LOG EMPTY<cr>

**R POS<ent>**

FINDING NEW POSITION<cr>

**R KEY<ent>**

NVR KEY CLEARED<cr>

**R CONFIG<ent>**

CONFIGURATION SET TO DEFAULTS<cr>

RESET GPS RECEIVER

The command, R GPS, is to perform a complete reset of the GPS receiver. This is a radical procedure and should only be done when all other options have been eliminated. The R GPS command will set the receiver to default values, basically all parameters equal to 0. Next, a self-test is performed on the receiver. Finally, the unit is placed back into normal operating mode. The entire process takes about 10-12 seconds. At this point the receiver may take 20 to 30 minutes to achieve first fix. The only information retained by the receiver is the current date and time. This command is only available in TEST MODE.

**R GPS<ent>**

*TIME= 13:00:29 DATE= 1996-06-21 RESET GPS RECEIVER  
SELF-TEST= PASS*

SIGNATURE CONTROL COMMAND

This command is to read or set signature control on the 10MHz outputs. If a major alarm occurs and signature control is on, the rear panel 10MHz outputs will be disabled. The default is off.

**SC<ent>**

*SIGNATURE CONTROL ON or OFF<cr>*

**SC ON or OFF<ent>**

*SIGNATURE CONTROL ON or OFF<cr>*

SHORT GATE COMMAND

This TEST MODE command is to read or set the measurement gate to "Short Gate." Normal operation of the 8195 sets a measurement period of 1000 seconds, turning the short gate on sets the measurement period to 10 seconds. This function aids in solving internal problems, but it greatly reduces the accuracy of the 10 MHz. Therefore, using Short Gate is a major alarm condition. The default is Short Gate Off.

**SG<ent>**

*SHORT GATE ON or OFF<cr>*

**SG ON or OFF<ent>**

*SHORT GATE ON or OFF<cr>*

HIGH D/A SETTING COMMAND

This TEST MODE command is to set the D/A control voltage to its maximum setting. For this unit the high setting is 6.5 volts, this command sets the D/A to that value.

**SHI<ent>**

*D/A= A666<cr>*

## **Section 4: Software Commands**

---

### **LOW D/A SETTING COMMAND**

This TEST MODE command is to set D/A control voltage to minimum setting for Oscillator. For this unit the low setting is 3.0 volts, this command sets the D/A to that value.

**SLO<ent>**

*D/A= 4CCD<cr>*

### **SET MODE COMMAND**

This command is to read or set the Set Mode. In order to enter parameters for any command the unit must be in Set Mode (SET MODE ON). The unit will time out of Set Mode if no command has been entered for 15 minutes. The default is Set Mode Off. SET MODE ON is displayed in the Display Status command when on.

**SM<ent>**

*SET MODE ON or OFF<cr>*

**SM ON or OFF<ent>**

*SET MODE ON or OFF<cr>*

### **DISPLAY SIGNAL STRENGTH**

The Signal Strength command, SS, provides signal strength, tracking Mode, satellite ID and status of each satellite received. Signal strength data is useful in qualifying antenna placement and receiver performance of an installation.

To retrieve the signal strength table type:

**SS <ent>**

Example Response is shown below:

<b>CHAN</b>	<b>VID</b>	<b>MODE</b>	<b>STREN</b>	<b>STAT</b>
01	03	08	039	A8
02	15	08	047	A0
03	18	08	038	A8
04	19	08	063	A0
05	00	00	000	00
06	27	08	055	A0
07	02	08	050	A8
08	31	08	065	A0

CHAN = Channel number of the GPS receiver, 01...08

VID = Vehicle (Satellite) Identification Number, 01...37

MODE = Channel tracking mode, 01...08  
Where: 00 - Code Search            05 - Message Sync Detect  
         01 - Code Acquire           06 - Satellite Time Avail  
         02 - AGC Set                 07 - Ephemeris Acquire  
         03 - Freq Acquire           08 - Avail for Position  
         04 - Bit Sync Detect

STREN = Signal strength value relative to SNR, 000...255. The higher the number, the greater the received signal.

STAT = Channel status flag. Convert the hexadecimal code word to binary to find the status flags set.

(MSB)     Bit 7: Using for Position Fix  
           Bit 6: Satellite Momentum Alert Flag  
           Bit 5: Satellite Anti-Spoof Flag Set  
           Bit 4: Satellite Reported Unhealthy  
           Bit 3: Satellite Reported Inaccurate (>16 meters)  
           Bit 2: Spare  
           Bit 1: Spare

(LSB)     Bit 0: Parity Error

Example:     HEX code word **A0** translates to the following flags set.  
                 Bit 7: Using for Position Fix  
                 Bit 5: Satellite Anti-Spoof Flag Set

**TIME COMMAND**

This command is to read or set the time. After the unit has acquired satellites it will receive time and date information from them. When the unit is initially powered on it will acquire satellites faster if it has the correct time and date information. The leading character of the response is the on time point. This information is also provided in the Display Status command.

**T<ent>**  
TIME= HH:MM:SS<cr>  
**T HH:MM<ent>**  
TIME= HH:MM:SS<cr> (seconds unchanged)  
**T HH:MM:SS<ent>**  
TIME= HH:MM:SS<cr>

**TEST BATTERY COMMAND**

This TEST MODE command is to manually initiate a battery test. Units that have a battery automatically test the battery at midnight. This command allows the user to test the battery on demand. The test consists of putting a load on the battery for up to 4 minutes and 15 seconds. After the test is complete, the unit responds with a battery status message, and a battery test entry is recorded into the performance log.

**TB<ent>**  
PERFORMING BATTERY TEST ...<cr>  
BATTERY STATUS= CHARGING or READY or REPLACE or NO BATTERY<cr>

## Section 4: Software Commands

---

### TIME LOG REQUEST

This TEST MODE command is to read the number of seconds since turn on, counted by the RTC.

**TL<ent>**

*TIMELOG= sssss SECONDS<cr>*

### TEST MODE COMMAND

This command is to read or set the Test Mode. Test Mode is a group of special commands designed to allow the user to debug a system problem. The unit will time out of Test Mode if no command has been entered for 15 minutes. The default is Test Mode Off. Entering Test Mode triggers both a Major and Minor alarm.

**TM<ent>**

*TEST MODE ON or OFF<cr>*

**TM ON or OFF<ent>**

*TEST MODE ON or OFF<cr>*

### TIME ZONE OFFSET COMMAND

This command is to read or set time zone. This command allows the user to set the 8195's clock to local time. All time stamps will reflect the time zone offset. The default setting is 0, which is UTC time. NOTE: The GPS time system has no indication for Daylight Savings Time, if the user wishes to have the time reflect DST they will need to change the time zone offset twice per year.

**TZO<ent>**

*TIMEZONE= sHH:MM<cr>* where s= + or -, and HH = 00 to 23, and MM=00 to 59

**TZO sHH:MM<ent>**

*TIMEZONE= sHH:MM<cr>*

### VERSION DISPLAY

This command is to give the program version and time and date the unit was first powered on. This information is also displayed when the Display Performance Log command is used.

**VER<ent>**

*SPECTRACOM CORPORATION GPS DISCIPLINED OSCILLATOR 8195<cr>*

*SOFTWARE VERSION 1.00 DATE: JANUARY 27, 1995<cr>*

*UNIT STARTED HH:MM:SS MM-DD-YY<cr>*

**10MHZ OFFSET COMMAND**

This command allows the user to read or set the 10MHz offset. These offsets are defined in Section 3.3.3.2 and Section 5.6 of this manual. The default is none. This information is also provided in the Display Configuration command.

**1FO<ent>**

*10MHZ OFFSET= NONE<cr>* or

*10MHZ OFFSET= SCn so<cr>* where n=1 or 2, s=+ or -, and o=1,2,3, or 4 OR

*10MHZ OFFSET = TV sc<cr>* where s=+ or - and c= 2 to 13

**1FO O<ent>**

*10MHZ OFFSET= NONE<cr>*

**1FO SCn so<ent>**

*10MHZ OFFSET= SCn so<cr>*

**1FO TV sc<ent>**

*10MHZ OFFSET= TV sc<cr>*

**1PPS OFFSET COMMAND**

This command is to read or set the 1PPS offset. The purpose of this command is to control the 9600, and 300 or 33.3 Hz outputs. Those outputs are synchronized to the 1PPS. The 10MHz outputs are not affected by this offset. The default is 0. This information is also provided in the Display Configuration command.

**1PO<ent>**

*1PPS OFFSET= 000000.000 MICROSECONDS<cr>*

**1PO 000000.000<ent>** NOTE: offset may be entered using 1 to 9 digits.

*1PPS OFFSET= 000000.000 MICROSECONDS<cr>*

## Section 4: Software Commands

---

### 4.2 RS-485 COMMANDS

The commands described here must conform to a specific command protocol. The protocol is as follows:

FIELD	SIZE	DESCRIPTION
Start Word	2 Bytes	Unique characters <#> <\$> used to synchronize with data stream
Source Address	1 Byte	0-31= unit address 32-254= reserved 255= broadcast
Destination Address	1 Byte	0-31= unit address 32-254=reserved 255= broadcast
Message Length	2 Bytes	Variable length from 1 to 502 bytes
Message	1 to 502 Bytes	4 character commands plus parameters
Check Word	2 Bytes	Running sum including all bytes after the start word through the last message byte.
Stop Word	2 Bytes	Unique characters (<cr><lf>) used to synchronize with data stream

**TABLE 4-2 RS-485 COMMAND PROTOCOL**

All inputs via the RS-485 port must follow this format, or they will be ignored. The descriptions that follow are for the Message field of the commands. When the first character of a command is 'w' this indicates the controller is writing information to the 8195. If the first character is 'r' the controller is reading information. The RS-485 Com port operates at 9600 baud, character structure is 1 start, 8 data, 1 stop, and no parity.

	<b>DESCRIPTION</b>	<b>READ</b>	<b>WRITE</b>
ACD	Antenna Cable Delay	√	√
AEH	Alarm Event History	√	
AST	Alarm Status Display	√	
AT1	Alarm Time Out 1	√	√
AT2	Alarm Time Out 2	√	√
AT3	Alarm Time Out 3	√	√
CAH	Clear Alarm History		√
LOC	Full location	√	√
STS	Short Status Display	√	
TAD	Time and Date	√	
TZO	Time Zone		√
VSC	Allows access to all RS232 commands		√
WHO	Vendor, Version	√	
1FO	Ten MHz Offset	√	√
1PO	One PPS Offset	√	√

**TABLE 4-3 ALPHABETICAL LIST OF RS-485 COMMANDS**

ANTENNA CABLE DELAY

This command is to read or set the antenna cable delay. Although this value is generally negligible, the 1PPS timing can be affected by the antenna cable delay. The default is 0. The maximum delay value is 999.999 microseconds.

**wacdXXXXXXXX.XXX** where XXXXXX.XXX is a number in microseconds.

wacdXXXXXXXX.XXX

**racd**

racdXXXXXXXX.XXX

## Section 4: Software Commands

---

### ALARM EVENT HISTORY

This command is to read alarm events. The 8195 will respond with the most recent alarm event not yet returned by this command. When all events have been read, the most recent event is returned with the valid entry indicator set to 'n' (event already read).

#### **raeh**

*raeh VHHMMSSsHHMMDDMMYYYYTNTFOCsAOGBss* where V = y or n indicating if this entry is a valid entry, HHMMSS= time of event, sHHMM= timezone offset of the unit, DDMMYYY= date of event, T(y/n) = 10 MHz out of specification (AT3), N(y/n) = 9.6 kHz out of spec (AT2), T(y/n)= in test mode, F(y/n)= in Free Run, O(y/n)= Oscillatory Failure (Frequency Alarm), C(y/n)= CPU alarm, sss= three spares, A(y/n)= Adjust Oscillator, O(y/n)= Output fault, G(y/n)= GPS out of spec (AT1), B(y/n)= replace battery, ss= two spares.

### ALARM STATUS

This command read alarm status. This is a short command designed to let the controller know if there are any alarms present.

#### **rast**

*rastC* where C = y or n indicating if there are alarm conditions present.

### ALARM TIMEOUTS

This command is to read or set the three Alarm Timeouts individually. Each time-out controls the status of an alarm relay. If the GPS receiver stops tracking satellites, these timers start counting down. If the timer reaches 0 before the receiver begins to track satellites again, the alarm relay is activated. In addition, if Alarm Timeout 1 occurs, this is a minor alarm. Alarm Timeout 2 and Alarm Timeout 3 are Major alarms. Defaults are: AT1 = 1 minute, AT2 = 2½ hours, AT3 = 30 days.

**watXDDDHHMMSS** where X = 1,2, or 3 indicating which time out.

*watXDDDHHMMSS*

#### **ratX**

*ratXDDDHHMMSS*

### CLEAR ALARM HISTORY

This command is to clear the alarm history. This command accompanies the raeh command and is used to "erase" the alarm history. After this is issued, subsequent use of the raeh command will respond with the valid entry character set to 'n', until a new alarm event occurs.

#### **wcah**

*wcah*

**LOCATION**

This command is to read or set the location. The GPS receiver will automatically find its correct position, but the time to first fix can be shortened by entering an approximate position. Entering position data is not required after initial installation because the unit will retain it after loss of power.

**wlocLDDMMSSMMMLDDDMMSSMMM**

*wlocLDDMMSSMMMLDDDMMSSMMM* Where L= latitude direction N or S, DD= degrees 00 to 90, MM= minutes, SS= seconds, MMM= milliseconds, L= longitude direction E or W, DDD= degrees 000 to 180, MM= minutes, SS= seconds, MMM= milliseconds.

**rloc**

**rlocLDDMMSSMMMLDDDMMSSMMMHHHHHP**

First 21 characters same as wloc, plus HHHHP where HHHH= height in meters, and P= Y or N for position Hold yes or no.

**SHORT STATUS**

This command gives a short status string. The controller can read this status information for alarm conditions. This command would generally be issued after the controller has polled the 8195 using the Alarm Status command.

**rsts**

*rstsSDDDDHHMMSSDDDDHHMMSSDDDDHHMMSSSSDD.D32TFFCsssAO1Bss* where S = number of satellites, DDD= days remaining T1, HHMMSS= time remaining T1, DDD= days remaining T3, HHMMSS= time remaining T3, DDD= days remaining T2, HHMMSS= time remaining T2, SDD.D= internal temperature, 3=y or n for T3 timed out, 2(y/n)= T2 timed out, T(y/n)= test mode, F(y/n)= free run, F(y/n)= Frequency alarm (oscillator failure), C(y/n)= cpu alarm, sss = three spares, A(y/n)= oscillator adjust, O(y/n)= output fault, 1(y/n)=T1 time out, B(y/n)= replace battery, ss = two spares.

**TIME AND DATE**

This command is to read the date and time. The leading character of the RS-485 protocol message is the "on-time" point.

**rtad**

*rtadHHMMSSsHHMMDDMMYYYY* where HH = hours 00 to 23, MM = minutes, SS = seconds, s = sign of TimeZone offset, HHMM = hours and minutes of TimeZone offset, DD = days, MM = months, and YYYY = year.

**TIME ZONE OFFSET**

This command allows the user to set the 8195's clock to local time. All time stamps will reflect the time zone offset. The default setting is 0, which is utc time. NOTE: The GPS time system has no indication for Daylight Savings Time, if the user wishes to have the time reflect DST they will need to change the timezone offset twice per year.

**wtzoSHHMM**

*wtzoSHHMM* where S= + or -, and HH = 00 to 23, and MM=00 to 59

## Section 4: Software Commands

---

### WHO

This command is to inform the controller of the vendor and software version.

#### ***rwho***

*rwho*SPECTRACOMMODEL 8195VX.XX Where X.XX is software version.

### 10MHZ OFFSET

This command allows the user to read or set the 10MHz offset. These offsets are the SC2 offsets defined in another section of the manual. The default is none.

***w1foSX*** where S = + or - and X = 1 to 4

*w1foSX*

#### ***r1fo***

*r1foSX*

### 1PPS OFFSET

This command is to read or set the 1PPS offset. The purpose of this command is to control the 9600, and 300 or 33.3 Hz outputs. Those outputs are synchronized to the 1PPS. The 10MHz outputs are not affected by this offset. The default is 0.

***w1poXXXXXX.X*** where XXXXXX.X is a number in microseconds.

*w1poXXXXXX.X*

#### ***r1po***

*r1poXXXXXX.X*

### INVALID COMMANDS

***BLAH*** No Response, just ignore message

# **OPTIONS AND ACCESSORIES**

## **5.0 INTRODUCTION**

This section describes the following options and accessories that are available for the Model 8195.

- Internal Battery Backup - Option 02
- Internal Trunk Line Distribution Amplifier - Option 03
- Distribution Accessories Line Taps - Model 8140T Line Extender Amplifier - Model 8140TA VersaTap™ Frequency Synthesizer Model 8140VT MultiTap - Model 8140MT
- 5-MHz Outputs - Option 07
- 1-MHz Outputs - Option 08
- Slides for Rack Mount - Option 11
- 10 Hz Channel Offset - Option 31
- DC Input Option 52
- Antenna Accessories Antenna Surge Suppressor Model 8226 Antenna Preamp Model 8227 Antenna Base Model 8213

The Model 8225 Antenna is described in Section 2.1.

## **5.1 OPTION 02 INTERNAL BATTERY BACKUP**

Option 02 provides the Model 8195 with an internal battery backup power source. The battery powers the ovenized oscillator and GPS receiver whenever AC power fails or is turned off. Battery backup allows quick recovery when AC power returns by eliminating oscillator warm up and GPS reacquisition. The battery pack typically provides 18 hours of backup operation.

## ***Section 5: Options and Accessories***

---

**NOTE:** The battery backup powers only the oscillator and GPS receiver during AC power failures. Outputs are not provided under backup operation.

The battery is continuously float-charged whenever AC power is present. Maximum recharge period is 20 hours. The battery is tested daily to verify battery operation. At midnight “receiver time” the microprocessor enables the battery pack to power the oscillator and GPS receiver for approximately four minutes. The battery test is transparent to unit operation. If the battery falls below the minimum voltage setpoint, the test is discontinued and the Replace Battery alarm is asserted.

The battery may be tested at anytime by initiating the Test Battery command, TB, through the RS-232 Com port.

### ***5.1.1 Battery Lamps***

Units equipped with Option 02 include front panel indicators to communicate battery status.

*Ready Lamp:* This green lamp is on when the battery is OK and fully charged. This lamp is off while the battery is tested.

*Charging Lamp:* This yellow lamp is on when the battery is charging. This lamp is off while the battery is tested.

*Replace Lamp:* This red lamp turns on and a Minor Alarm asserted when the battery has failed the daily test. The battery must be replaced.

### ***5.1.2 Option 02 Specifications***

Battery: 12V, 7 A/H, sealed lead acid

Backup Operation: 12 hours minimum  
18 hours typical

Recharge Rate: 20 hours maximum from complete discharge

Charge Current: 500 milliamps maximum  
10 milliamps float-charge

Battery Life: 5 years typical

## ***5.2 OPTION 03 BUILT IN DISTRIBUTION AMPLIFIER***

Option 03 allows counters and synthesizers throughout a facility to use the GPS disciplined outputs from a Model 8195 as a common time base. Allowing

equipment to share an accurate common time base eliminates the need to buy expensive, high stability time bases for each instrument or remove them from service for periodic calibration.

Units equipped with Option 03 may drive up to 25 remote stations. Multiple outputs are provided on the rear panel so that signals may be sent in several different directions. A Line Tap at each remote station receives DC power and the 10-MHz from the main coaxial trunk line cable. The signal is buffered then divided to the frequency needed at that station. After filtering, the signal is available at the Line Tap output. New stations are easily added to the system by inserting additional Line Taps.

### **5.2.1 System Components**

A frequency distribution system may use Model 8140T Line Taps, Model 8140VT VersaTaps™, Model 8140TA Line Extender Amplifiers or Model 8140MT MultiTaps. The following paragraphs describe each of these units.

#### *5.2.1.1 Model 8140T Line Taps.*

These devices, powered by DC on the coaxial feedline, are attached to the coaxial distribution network and provide an output frequency at one of 100 kHz, 1 MHz, 5 MHz, or 10 MHz.

*Input:* Buffered high input impedance causes negligible mismatch on main trunk line distribution cable. Accepts signal levels provided by the base station equipped with Option 03.

*Output Level:* 600 mV rms sinewave into 50 ohms. When used without termination, the output is TTL compatible.

*Output Frequencies:* 10, 5.0, 1.0, or 0.1 MHz. Specify frequency for each Line Tap ordered.

*Harmonic Distortion of Output:* -40 dB

*Crosstalk (Isolation):* 80 dB minimum.

*Output Phase Noise:* Typically less than -130 dB/Hz 1 kHz from carrier for 10 MHz input to base station amplifier.

*Line Tap Size:* In inches - 5.25 L x 2.63 W x 1.71 H. (In mm: 133 L x 67 W x 43 H). Mounting hole pattern: 4.75 x 1.75 inches (121 x 44 mm).

## **Section 5: Options and Accessories**

---

### **5.2.1.2 Model 8140VT VersaTap™ Frequency Synthesizer**

The VersaTap™ is a single-frequency synthesizer whose output is factory-set to any frequency between 1 kHz and 16 MHz in 1-kHz increments and up to 20 MHz in 2 kHz increments. Some special frequencies can be furnished, such as the 3.5795454...MHz TV color sub-carrier. Exact frequencies must be specified at time of order.

*Input:* Buffered high impedance input. Accepts 10.0 MHz with signal level between 100 millivolts and 5.5 V p-p on a DC voltage of 7 to 12 VDC. The DC current requirement is 110 milliamps at +12 VDC.

*Output A:* A sine wave of 600 mV rms at the specified frequency into a 50-ohm load for frequencies greater than 100 kHz. A TTL output for frequencies below 100 kHz with a source impedance of 50 ohms (SN74S140) driver.

*Output B:* A TTL output at the specified frequency with a source impedance of 50 ohms (SN75S140 driver). If the internal jumper, W6, is moved to location W5, Output B is HIGH when the VersaTap™ is phase locked to the incoming reference and LOW when it is unlocked.

*Lock LED:* The LED will light when the VersaTap™ is locked to the incoming reference. The LED will blink if the DC input is low, which may cause the VersaTap™ to malfunction. The LED will be unlit when the VersaTap™ is not locked to the incoming reference.

*VersaTap™ Size:* In inches 8.3 L x 4.2 W x 1.7 H. (In mm: 211 L x 107 W x 43 H). Mounting hole pattern 8.88 x 2.75 inches (225.4 x 69.9 mm).

### **5.2.1.3 Model 8140TA Line Extender Amplifier**

The Line Extender Amplifier must be used to boost the output signal when the coaxial distribution network is more than 1500 feet (457 m) long. The Line Extender will drive an additional 1500-feet (457 m) of RG58 coaxial cable with Model 8140 Line Taps installed along its length.

Two DC-isolated 50-ohm terminators must be used: one at the input tee connector of the Line Extender Amplifier and one at the far end of the cable connected to the output of the Line Extender Amplifier.

See the “Typical Interconnection Diagram” at the end of this section for an approved method of interconnection.

**5.2.1.4 Model MultiTap**

The Spectracom Model 8140MT MultiTap is a programmable frequency divider/buffer. Three outputs can be configured to the same frequency or set independently. When used as part of your Spectracom Distribution System it decreases the cost per output and allows future modifications as requirements change.

*Frequency Outputs:* Three square wave outputs per MultiTap. 1.5V p-p into 50 ohms. Once a group is chosen, any divisor in a group may be individually selected.

Table of output divisors:

<b>Group A</b>	<b>B</b>	<b>C</b>	<b>D</b>
1	1	5	5
2	2	10	10
10	20	50	100
50	100	250	500
250	500	1250	2500

For a 10-MHz input, the available outputs in MHz are:

<b>Group A</b>	<b>B</b>	<b>C</b>	<b>D</b>
10.0	10.0	2.0	2.0
5.0	5.0	1.0	1.0
1.0	0.5	0.2	0.1
0.2	0.1	0.04	0.02
0.04	0.02	0.008	0.004

*Power Requirements:* When driven by a Distribution Amplifier, the DC load equals three Line Taps. Option 40, which is required for stand-alone operation, reduces the distribution load to one Line Tap equivalent, and is required whenever output frequencies are below 100 kHz. Maximum current is less than 150 mA.

*MultiTap size:* 5.25L x 2.63W x 1.71H in.  
(133L x 67W x 43H mm)

*Mounting hole:* 4.75 x 1.75 in. (121 x 44 mm)

## **Section 5: Options and Accessories**

### *5.2.2 Design of Distribution Networks*

This section provides guidelines for using the Option 03 distribution outputs. In planning a system installation follow the guidelines listed below:

1. A maximum of 25 Line Tap loads may be driven from one base station. More than 25 loads is not permitted due to power supply limitations and impedance matching. Table 5-1, LINE TAP LOADS, lists the equivalent number of loads and current each distribution device consumes. The receiver may provide up to 1.2 amps total to the distribution network.

<b>DEVICE</b>	<b>LOADS</b>	<b>CURRENT (mA)</b>
8140T All Versions	1	45
8140TA	1	45
8140VT Standard	3	150
8140VT w/Opt 45	5	250
8140VT w/Opt 48	4	200
8140VT w/Opt 62	4	200
8140MT	3	150

**TABLE 5-1 LINE TAP LOADS**

If more than 25 Line Tap loads are required you may:

Add a Model 8140 Frequency Distribution Amplifier. The Model 8140 contains an internal power supply and will feed an additional 25 Line Tap loads. A Line Tap is required (typically 10 MHz) to provide the input frequency source to the Model 8140. This “Daisy Chaining” may be continued indefinitely.

2. Because of voltage drops and signal attenuation the longest trunk line using RG-58 cable is 1500 feet (457 m).

Figure 5-1, LINE TAP NUMBER AND DISTANCE CHART, is used to calculate the number of Line Tap loads that may be used at various distances from the base station.

For example, if 25 Line Taps are used, their average distance from the amplifier is limited to 750 feet (228 m), using RG-58. Up to 12 Line Taps may be placed at 1500 feet (457 m) on any one trunk line.

If longer runs are required, you may:

- A. Locate the Model 8195 in the geographical center of the installation, running distribution lines in both directions and achieving a coverage of 3000 linear feet (914 m).

**FIGURE 5-1 LINE TAP NUMBER AND DISTANCE CHART - OPTION 03**

- B. Use a Model 8140TA Line Extender Amplifier at 1500 feet, allowing a further 1500-foot (457 m) extension of the distribution line. The Model 8140TA counts as one Line Tap towards the total number allowed. Use a Distribution Line Termination, Part Number 004490, at the input tee connector and at the end of the extended line section as shown in the “Typical Interconnection Diagram”, Figure 5-2.
  - C. Use a Model 8140 Frequency Distribution Amplifier.
3. Each distribution line must be continuous from the base station to the DC isolated 50 ohm load that must be used at the far end. Line taps are inserted along the distribution line by using the supplied input tee connector. No branching or “Y” configurations may be used as this causes impedance mismatch on the line. Anything other than a 50 ohm line impedance may cause reflections which can cancel the output waveform at the receiver triggering the output fault lamp. Refer to the Figure 5-2, TYPICAL INTERCONNECTION DIAGRAM, for an approved method of interconnection.
  4. Four DC-isolated 50 ohm loads are furnished with each unit equipped with Option 03. They may be found in the ancillary kit that is packed with each unit when it leaves the factory. If any of these loads are lost, spares may be purchased from Spectracom. The part number to order is 004490. Terminators may be placed on any unused distribution output connector to prevent loss.

## Section 5: Options and Accessories

- We recommend that, wherever practical, the Line Taps be permanently mounted to a lab bench or wall nearby. This avoids their loss or misplacement and discourages people from occasionally disconnecting them, thus cutting off the signal to stations further down the line.
- NEVER DIRECTLY CONNECT A DISTRIBUTION LINE TO AN INSTRUMENT; always use a Line Tap, Multitap or VersaTap™. Direct connection may damage the instrument or cause an impedance mismatch on the distribution line.

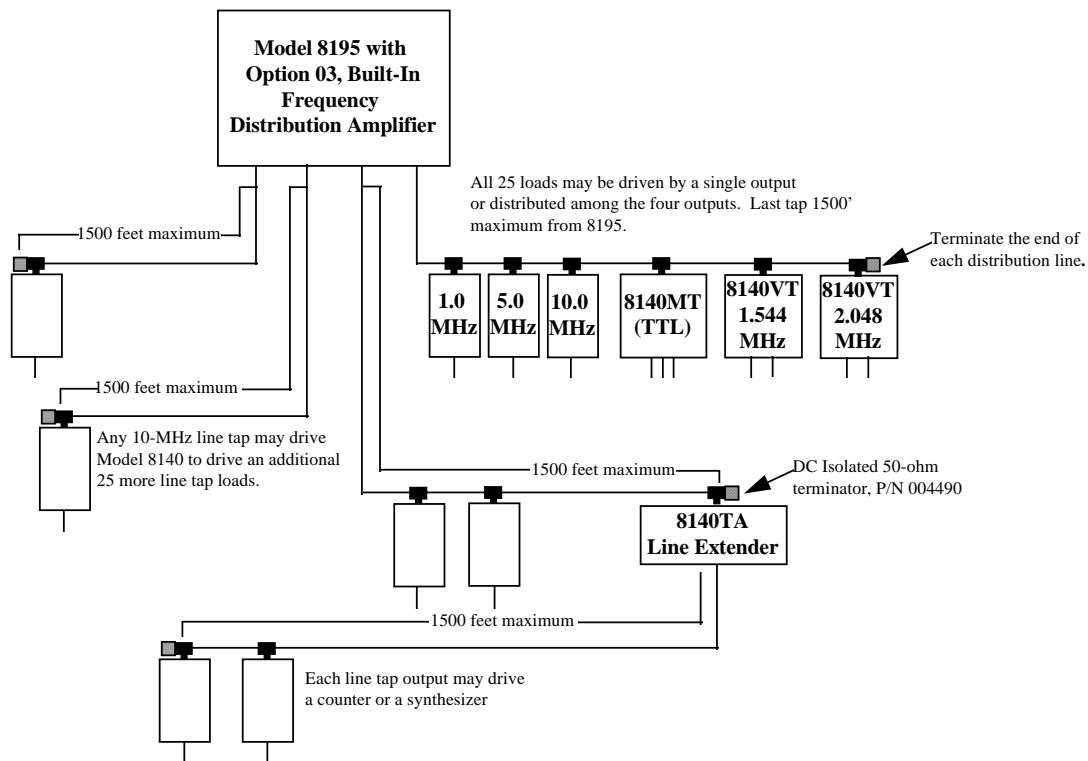

FIGURE 5-2 TYPICAL INTERCONNECTION DIAGRAM

### 5.3 OPTION 07 - 5-MHZ OUTPUTS

Option 07 changes the rear panel frequency outputs from 10.0 MHz to 5 MHz. The output is a 600 mV rms sine wave into 50 ohms. Harmonic suppression is better than -30 dBc.

### 5.4 OPTION 08 - 1-MHZ OUTPUTS

Option 08 changes the rear panel frequency outputs from 10.0 MHz to 1.0 MHz. The output is a 600 mV rms sine wave into 50 ohms. Harmonic suppression is better than -30 dBc.

**5.5 OPTION 11 - RACK MOUNT SLIDES**

Option 11 allows the Model 8195 to be mounted in a 19-inch rack with slide-out capabilities. Table 5-2 lists the hardware supplied with Option 11. Verify that these items have been received. Much of the hardware supplied with this option will not be used.

<b>QUANTITY</b>	<b>DESCRIPTION</b>
1	Right hand slide assembly
1	Left hand slide assembly
2	Filler plates (not used)
2	Adjustable rear support bracked
1	Hardware Pack containing nut plates, small rear support brackets, and assorted hardware
1	Hardware pack containing PEM nutes and #10-32 x 1/2 truss head screws
1	Hardware pack containing #10 KEP nuts and #10-32 x 3/8 pan head screws.

**TABLE 5-2 OPTION 11 CHECKLIST**

Install Option 11 as illustrated in Figure 5-3 and as described below:

1. Remove the chassis section from the right hand slide rail assembly. The right hand assembly is designated with the letters *RH* after the manufacturer's date code label.  
Attach the chassis section to the Model 8195 using #10-32 screws. The locking tab must be towards the rear of the unit.
2. Repeat Step 1 for the left chassis section.
3. Mount the right and left stationary sections into the rack using the appropriate rear support brackets, nut plates and required hardware.

---

**Note:** Insert the intermediate section into the stationary section prior to rack installation.

---

1. Insert the receiver into the rack assembly. Secure the Model 8195 to the rack using the front panel mounting holes.

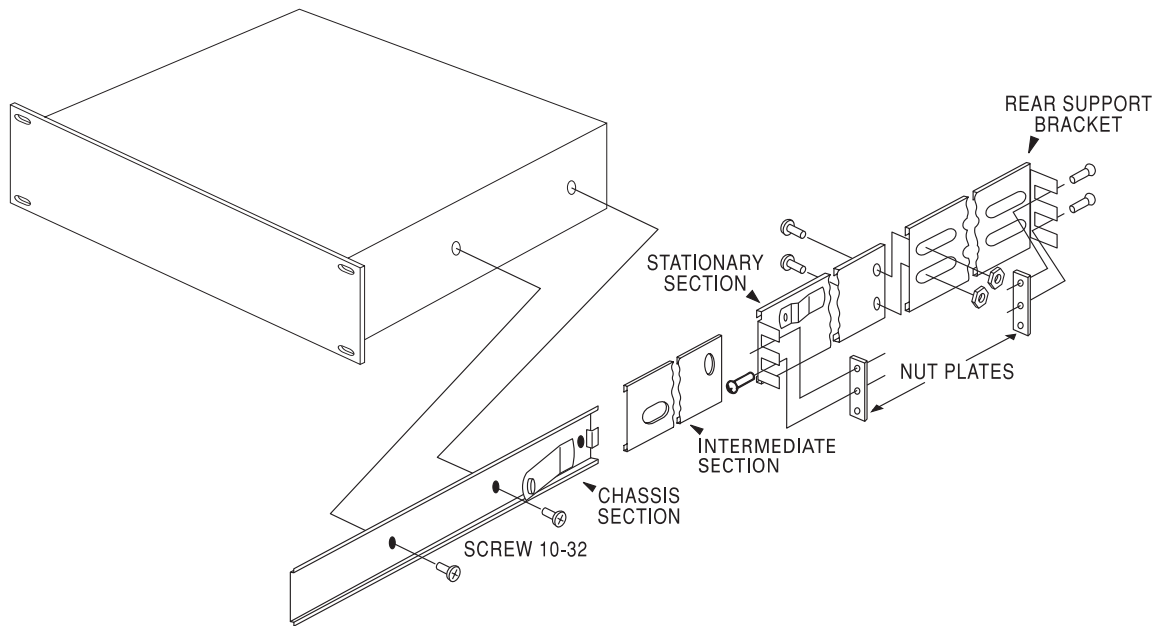

**FIGURE 5-3 SLIDES, OPTION 11**

### **5.6 OPTION 31 10-HZ CHANNEL OFFSET**

To avoid interference between TV stations operating on the same frequency, geographical separation and radiated powers are carefully selected. Nevertheless, considerable co-channel interference has been encountered.

Co-channel interference between TV stations appears to viewers as a horizontal pattern of alternating light and dark bars much like the shadows cast by venetian blinds. The visibility of these bars varies cyclically as a function of the difference frequency of the interfering carriers.<sup>\*1\*</sup>

Co-channel interference can be minimized if the transmitter frequencies are tightly controlled. To minimize the interference, the visual carrier of an interfering station is offset by either plus or minus 10,010 Hz. The 10-kHz offset and the direction (i.e. plus or minus) is assigned by the FCC. This offset is normally provided in the transmitter. The Model 8195 GPS Ageless Oscillator with Option 31 provides a precise 10-MHz standard with offset control that, when translated to the visual carrier frequency results in an additional 10 Hz offset.

The television offsets are selected using the RS-232 communication ports. Refer to the 10-MHz Offset Command, 1F0, found in Section 4 for additional information.

Table 5-3 lists the frequency offset name and the resulting output frequencies.

---

<sup>1</sup> "Precise Frequency Control, Theory and Practice" by J. L. Klecker and A. H. Bott, Engineering Report, Harris Corporation, Broadcast Division, 123 Hampshire St., Quincy, IL 62301.

<b>OFFSET NAME</b>	<b>OUTPUT FREQUENCY</b>
TV + 2	10,000,001.810
TV + 3	10,000,001.632
TV + 4	10,000,001.487
TV + 5	10,000,001.294
TV + 6	10,000,001.201
TV + 7	10,000,000.571
TV + 8	10,000,000.552
TV + 9	10,000,000.534
TV + 10	10,000,000.517
TV + 11	10,000,000.502
TV + 12	10,000,000.487
TV + 13	10,000,000.473
TV - 2	9,999,998.190
TV - 3	9,999,998.367
TV - 4	9,999,998.513
TV - 5	9,999,998.706
TV - 6	9,999,998.799
TV - 7	9,999,999.429
TV - 8	9,999,999.448
TV - 9	9,999,999.466
TV - 10	9,999,999.483
TV - 11	9,999,999.498
TV - 12	9,999,999.513
TV - 13	9,999,999.527

**TABLE 5-3 TV OFFSETS**

## **5.7 OPTION 52 DC POWER INPUT**

Option 52 configures the Model 8195 for operation from a  $\pm 10$  to 36 VDC power source. The DC power connector provides for redundant power connections. The isolated power inputs allow either positive or negative supply voltage polarity.

### **5.7.1 Option 52 Specifications**

Input Power:  $\pm 10$  to 36 VDC, 20 watts maximum  
 Fuse: 2 amp, 250V, Slo-Blo  
 Connector: Removable 6-position terminal block (supplied)

## **5.8 ANTENNA ACCESSORIES**

This section describes the antenna accessory items offered by Spectracom.

### **5.8.1 Model 8226 Impulse Suppressor**

Spectracom recommends the use of an inline coaxial protector for all products with an outside antenna. Spectracom offers the Model 8226, Impulse Suppressor, to protect the receiver from damaging voltages occurring on the antenna coax. The Model 8226, shown in Figure 5-4, mounts to a single point grounding panel or bulkhead. Voltages exceeding the impulse suppressor trip point are shunted to the system ground.

The Model 8226 is designed to withstand multiple surges.

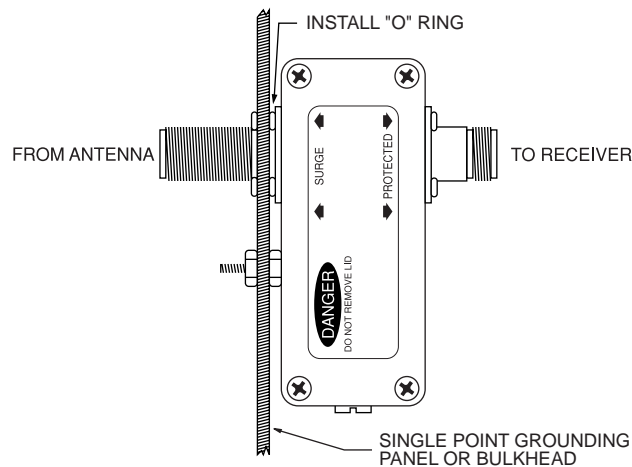

**FIGURE 5-4 MODEL 8226 IMPULSE SUPPRESSOR**

#### ***Specifications***

Connectors:	Type N Female
Turn On Time:	4 nanoseconds for 2 kV/ns
Turn On Voltage:	+7 V to -1 V
Frequency Range:	1.2 to 2.0 GHz
VSWR:	1.1:1 or better
Insertion Loss:	0.1 dB maximum

### **5.8.2 Model 8227 Inline GPS Amplifier**

The Model 8227 GPS Inline Amplifier is required whenever RG-213 antenna cable lengths exceed 200 feet<sup>11</sup>. The Model 8227, shown in Figure 5-5, extends the maximum antenna to receiver cable length to 400 feet.



**FIGURE 5-5 MODEL 8227 INLINE AMPLIFIER**

For best results install the amplifier as close to the antenna as possible. Spectracom recommends a **MAXIMUM** cable length of 100 feet between the antenna and the amplifier. This optimizes the signal to noise ratio of the antenna system. Due to unique system dynamics of the antenna, amplifier and receiver, a minimum RG-213 cable length of 250 feet is required to prevent overloading the receiver. Refer to the cable guidelines shown in Figure 5-6.

**FIGURE 5-6 CABLE GUIDELINES**

---

<sup>1</sup> When using Model 8225 GPS Antennas with serial numbers 8225-0839 and below, cable lengths exceeding 140 feet require an in-line amplifier.

## ***Section 5: Options and Accessories***

---

The Model 8227 Inline Amplifier and the Model 8225 GPS Antenna receive operating power from the Model 8195 Antenna connector. Install the amplifier between the impulse suppressor and the receiver whenever possible. Each Model 8227 includes two male "N" connectors to splice into the RG-213 antenna line. Weatherproof all connections when installed outdoors.

### ***Specifications***

Connectors:	Type N Female
Gain:	$20 \pm 3$ dB
VSWR:	$\leq 1.5:1$
Power:	3 - 9 VDC, $7.5 \pm 1$ milliamps

### ***5.8.3 Model 8213 Antenna Mount***

Spectracom offers the Model 8213 Antenna Mount for installations where vent pipe mounting is not practical or desired. The Model 8213, shown in Figure 5-7, is constructed of aluminum and is furnished with ballast for stability.

**FIGURE 5-7 MODEL 8213 ANTENNA MOUNT**

### ***5.8.4 Antenna Coax***

Spectracom offers GPS Antenna Cable Assemblies terminated with weatherproof Male Type N connectors. Cables are available in custom lengths up to 100 feet in 10 foot increments. Specify Part Number CA07xxx, where xxx equals the length in feet.